



- [Table of Contents](#)
- [Index](#)

Unix® Shell Programming, Third Edition

By Stephen G. Kochan, Patrick Wood

Publisher: Sams Publishing

Pub Date: February 27, 2003

ISBN: 0-672-32490-3

Pages: 456

Slots: 1

*Unix Shell Programming* is a tutorial aimed at helping Unix and Linux users get optimal performance out of their operating system. It shows them how to take control of their systems and work efficiently by harnessing the power of the shell to solve common problems. The reader learns everything he or she needs to know to customize the way a Unix system responds.

The vast majority of Unix users utilize the Korn shell or some variant of the Bourne shell, such as bash. Three are covered in the third edition of *Unix Shell Programming*. It begins with a generalized tutorial of Unix and tools and then moves into detailed coverage of shell programming.

Topics covered include: regular expressions, the kernel and the utilities, command files, parameters, manipulating text filters, understanding and debugging shell scripts, creating and utilizing variables, tools, processes, and customizing the shell.



- [Table of Contents](#)
- [Index](#)

Unix® Shell Programming, Third Edition  
By Stephen G. Kochan, Patrick Wood

Publisher: Sams Publishing  
Pub Date: February 27, 2003  
ISBN: 0-672-32490-3  
Pages: 456  
Slots: 1

[Copyright](#)

[About the Authors](#)

[We Want to Hear from You!](#)

[Reader Services](#)

[Chapter 1. Introduction](#)

[Chapter 2. A Quick Review of the Basics](#)

[Some Basic Commands](#)

[Working with Files](#)

[Working with Directories](#)

[Filename Substitution](#)

[Standard Input/Output and I/O Redirection](#)

[Pipes](#)

[Standard Error](#)

[More on Commands](#)

[Command Summary](#)

[Exercises](#)

[Chapter 3. What Is the Shell?](#)

[The Kernel and the Utilities](#)

[The Login Shell](#)

[Typing Commands to the Shell](#)

[The Shell's Responsibilities](#)

[Chapter 4. Tools of the Trade](#)

[Regular Expressions](#)

[cut](#)

[paste](#)

[sed](#)

[tr](#)

[grep](#)

[sort](#)

[uniq](#)

[Exercises](#)

## [Chapter 5. And Away We Go](#)

[Command Files](#)

[Variables](#)

[Built-in Integer Arithmetic](#)

[Exercises](#)

## [Chapter 6. Can I Quote You on That?](#)

[The Single Quote](#)

[The Double Quote](#)

[The Backslash](#)

[Command Substitution](#)

[Exercises](#)

## [Chapter 7. Passing Arguments](#)

[The \\$# Variable](#)

[The \\$\\* Variable](#)

[A Program to Look Up Someone in the Phone Book](#)

[A Program to Add Someone to the Phone Book](#)

[A Program to Remove Someone from the Phone Book](#)

[\\${n}](#)

[The shift Command](#)

[Exercises](#)

## [Chapter 8. Decisions, Decisions](#)

[Exit Status](#)

[The test Command](#)

[The else Construct](#)

[The exit Command](#)

[The elif Construct](#)

[The case Command](#)

[The Null Command :](#)

[The && and || Constructs](#)

[Exercises](#)

## [Chapter 9. 'Round and 'Round She Goes](#)

[The for Command](#)

[The until Command](#)

[More on Loops](#)

[The getopt Command](#)

[Exercises](#)

## [Chapter 10. Reading and Printing Data](#)

[The read Command](#)

[The printf Command](#)

[Exercises](#)

## [Chapter 11. Your Environment](#)

[Local Variables](#)

[Exported Variables](#)

[PS1 and PS2](#)

[HOME, James](#)

[Your PATH](#)

[Your Current Directory](#)

[More on Subshells](#)

[Your .profile File](#)

[The TERM Variable](#)

[The TZ Variable](#)

[Exercises](#)

## [Chapter 12. More on Parameters](#)

[Parameter Substitution](#)

[The \\$0 Variable](#)

[The set Command](#)

[The IFS Variable](#)

[The readonly Command](#)

[The unset Command](#)

[Exercises](#)

## [Chapter 13. Loose Ends](#)

[The eval Command](#)

[The wait Command](#)

[The trap Command](#)

[More on I/O](#)

[Functions](#)

[The type Command](#)

[Exercises](#)

## [Chapter 14. Rolo Revisited](#)

[Design Considerations](#)

[rolo](#)

[add](#)

[lu](#)

[display](#)

[rem](#)

[change](#)

[listall](#)

[Sample Output](#)

[Exercises](#)

## [Chapter 15. Interactive and Nonstandard Shell Features](#)

[Getting the Right Shell](#)

[The ENV File](#)

[Command-Line Editing](#)

[Command History](#)

[The vi Line Edit Mode](#)

[The Line Edit Mode](#)

[Other Ways to Access Your History](#)

[Functions](#)

[Integer Arithmetic](#)

[The `alias` Command](#)

[Arrays](#)

[Job Control](#)

[The Restricted Shell `rsh`](#)

[Miscellaneous Features](#)

[Compatibility Summary](#)

[Exercises](#)

#### [Appendix A. Shell Summary](#)

[Startup](#)

[Commands](#)

[Comments](#)

[Parameters and Variables](#)

[Command Re-entry](#)

[Quoting](#)

[Filename Substitution](#)

[I/O Redirection](#)

[Exported Variables and Subshell Execution](#)

[Functions](#)

[Job Control](#)

[Command Summary](#)

#### [Appendix B. For More Information](#)

[Online Documentation](#)

[Documentation on the Web](#)

[Books](#)

[Index](#)

# Copyright

## Copyright © 2003 by Sams Publishing

All rights reserved. No part of this book shall be reproduced, stored in a retrieval system, or transmitted by any means, electronic, mechanical, photocopying, recording, or otherwise, without written permission from the publisher. No patent liability is assumed with respect to the use of the information contained herein. Although every precaution has been taken in the preparation of this book, the publisher and author assume no responsibility for errors or omissions. Nor is any liability assumed for damages resulting from the use of the information contained herein.

Library of Congress Catalog Card Number: 2002115932

Printed in the United States of America

First Printing: March 2003

06 05 04 03 4 3 2 1

## Trademarks

All terms mentioned in this book that are known to be trademarks or service marks have been appropriately capitalized. Sams Publishing cannot attest to the accuracy of this information. Use of a term in this book should not be regarded as affecting the validity of any trademark or service mark.

## Warning and Disclaimer

Every effort has been made to make this book as complete and as accurate as possible, but no warranty or fitness is implied. The information provided is on an "as is" basis. The authors and the publisher shall have neither liability nor responsibility to any person or entity with respect to any loss or damages arising from the information contained in this book.

## Credits

Acquisitions Editor

*Katie Purdum*

Development Editor

*Scott Meyers*

Managing Editor

*Charlotte Clapp*

Copy Editor

*Geneil Breeze*

Indexer

*Erika Millen*

Proofreader

*Jessica McCarty*

Technical Editor

*Michael Watson*

Interior Designer

*Gary Adair*

Cover Designer

*Gary Adair*

Page Layout

*Susan Geiselman*

## Dedication

*To my father, Harry Wood  
—Patrick Wood*

*To Gregory, Linda, and Julia for giving meaning to my life  
—Stephen G. Kochan*

Team LiB

◀ PREVIOUS

NEXT ▶

# About the Authors

Stephen G. Kochan is the owner of TechFitness, a technology-based fitness company. Prior to that, he was president and CEO of Pipeline Associates, a company specializing in color printing software. Mr. Kochan is the author of several best-selling books on Unix and C programming, including the best-selling *Programming in C*. He also acted as Series Editor for the Hayden Unix System Library.

Patrick Wood is the CTO of the New Jersey location of Electronics for Imaging. He was a member of the technical staff at Bell Laboratories when he met Mr. Kochan in 1985. Together they founded Pipeline Associates, Inc., a Unix consulting firm, where he was the Vice President. They coauthored *Exploring the Unix System*, *Unix System Security*, *Topics in C Programming*, and *Unix Shell Programming*.



# We Want to Hear from You!

As the reader of this book, *you* are our most important critic and commentator. We value your opinion and want to know what we're doing right, what we could do better, what areas you'd like to see us publish in, and any other words of wisdom you're willing to pass our way.

You can email or write me directly to let me know what you did or didn't like about this book—as well as what we can do to make our books stronger.

*Please note that I cannot help you with technical problems related to the topic of this book, and that due to the high volume of mail I receive, I might not be able to reply to every message.*

When you write, please be sure to include this book's title and author as well as your name and phone or email address. I will carefully review your comments and share them with the author and editors who worked on the book.

Email: [feedback@sampublishing.com](mailto:feedback@sampublishing.com)

Mail: Mark Taber  
Associate Publisher  
Sams Publishing  
201 West 103rd Street  
Indianapolis, IN 46290 USA

## Reader Services

For more information about this book or others from Sams Publishing, visit our Web site at [www.sampublishing.com](http://www.sampublishing.com). Type the ISBN (excluding hyphens) or the title of the book in the Search box to find the book you're looking for.

# Chapter 1. Introduction

It's no secret that the Unix operating system has emerged as a standard operating system. For programmers who have been using Unix for many years now, this came as no surprise: The Unix system provides an elegant and efficient environment for program development. After all, this is what Dennis Ritchie and Ken Thompson strived for when they developed Unix at Bell Laboratories in the late 1960s.

One of the strongest features of the Unix system is its wide collection of programs. More than 200 basic commands are distributed with the standard operating system. These commands (also known as *tools*) do everything from counting the number of lines in a file, to sending electronic mail, to displaying a calendar for any desired year.

But the real strength of the Unix system comes not entirely from this large collection of commands but also from the elegance and ease with which these commands can be combined to perform far more sophisticated functions.

To further this end, and also to provide a consistent buffer between the user and the guts of the Unix system (the *kernel*), the shell was developed. The *shell* is simply a program that reads in the commands you type and converts them into a form more readily understood by the Unix system. It also includes some fundamental programming constructs that let you make decisions, loop, and store values in variables.

The standard shell distributed with Unix and Linux systems derives from AT&T's distribution, which evolved from a version originally written by Stephen Bourne at Bell Labs. Since then, the IEEE created standards based on the Bourne shell and the other more recent shells. The current version of this standard as of this revision is the Shell and Utilities volume of IEEE Std 1003.1-2001, also known as the POSIX standard. This shell is what we propose to teach you about in this book.

The examples in this book were tested on both SunOS 5.7 running on a Sparcstation Ultra-30 and on Silicon Graphics IRIX 6.5 running on an Octane; some examples were also run on Red Hat Linux 7.1 and Cygwin. All examples, except some Bash examples in [Chapter 15](#), were run using the Korn shell, although many were also run with Bash.

Many Unix systems are still around that have Bourne shell derivatives and utilities not compliant with the POSIX standard. We'll try to note this throughout the text wherever possible; however, there are so many different versions of Unix from so many different vendors that it's simply not possible to mention every difference. If you do have an older Unix system that doesn't supply a POSIX-compliant shell, there's still hope. We'll list resources at the end of this book where you can obtain free copies of three different POSIX-compliant shells.

Because the shell offers an interpreted programming language, programs can be written, modified, and debugged quickly and easily. We turn to the shell as our first choice of programming language. After you become adept at programming in the shell, you too may turn to it first.

This book assumes that you are familiar with the fundamentals of the Unix system; that is, that you know how to log in; how to create files, edit them, and remove them; and how to work with directories. But in case you haven't used the Unix system for a while, we'll examine the basics in

[Chapter 2](#), "A Quick Review of the Basics." Besides the basic file commands, filename substitution, I/O redirection, and pipes are also reviewed in [Chapter 2](#).

[Chapter 3](#), "What Is the Shell?," reveals what the shell really is. You'll learn about what happens every time you log in to the system, how the shell program gets started, how it parses the command line, and how it executes other programs for you. A key point made in [Chapter 3](#) is that the shell is just a program; nothing more, nothing less.

[Chapter 4](#), "Tools of the Trade," provides tutorials on tools useful in writing shell programs. Covered in this chapter are `cut`, `paste`, `sed`, `grep`, `sort`, `tr`, and `uniq`. Admittedly, the selection is subjective, but it does set the stage for programs that we'll develop throughout the remainder of the book. Also in [Chapter 4](#) is a detailed discussion of regular expressions, which are used by many Unix commands such as `sed`, `grep`, and `ed`.

[Chapters 5](#) through [10](#) teach you how to put the shell to work for writing programs. You'll learn how to write your own commands; use variables; write programs that accept arguments; make decisions; use the shell's `for`, `while`, and `until` looping commands; and use the `read` command to read data from the terminal or from a file. [Chapter 6](#), "Can I Quote You on That?," is devoted entirely to a discussion on one of the most intriguing (and often confusing) aspects of the shell: the way it interprets quotes.

By this point in the book, all the basic programming constructs in the shell will have been covered, and you will be able to write shell programs to solve your particular problems.

[Chapter 11](#), "Your Environment," covers a topic of great importance for a real understanding of the way the shell operates: the *environment*. You'll learn about local and exported variables; subshells; special shell variables such as `HOME`, `PATH`, and `CDPATH`; and how to set up your `.profile` file.

[Chapter 12](#), "More on Parameters," and [Chapter 13](#), "Loose Ends," tie up some loose ends, and [Chapter 14](#), "Rolo Revisited," presents a final version of a phone directory program called `rolo` that is developed throughout the book.

[Chapter 15](#), "Interactive and Nonstandard Shell Features," discusses features of the shell that either are not formally part of the IEEE POSIX standard shell (but are available in most Unix and Linux shells) or are mainly used interactively instead of in programs.

[Appendix A](#), "Shell Summary," summarizes the features of the IEEE POSIX standard shell.

[Appendix B](#), "For More Information," lists references and resources, including the Web sites where different shells can be downloaded.

The philosophy this book uses is to teach by example. Properly chosen examples do a far superior job at illustrating how a particular feature is used than ten times as many words. The old "A picture is worth..." adage seems to apply just as well to examples. You are encouraged to type in each example and test it on your system, for only by doing can you become adept at shell programming. You also should not be afraid to experiment. Try changing commands in the program examples to see the effect, or add different options or features to make the programs more useful or robust.

At the end of most chapters you will find exercises. These can be used as assignments in a classroom environment or by yourself to test your progress.

This book teaches the IEEE POSIX standard shell. Incompatibilities with earlier Bourne shell versions are noted in the text, and these tend to be minor.

Acknowledgments from the first edition of this book: We'd like to thank Tony Iannino and Dick Fritz for editing the manuscript. We'd also like to thank Juliann Colvin for performing her usual wonders copy editing this book. Finally, we'd like to thank Teri Zak, our acquisitions editor, and posthumously Maureen Connelly, our production editor. These two were not only the best at what they did, but they also made working with them a real pleasure.

For the first revised edition of this book, we'd like to acknowledge the contributions made by Steven Levy and Ann Baker, and we'd like to also thank the following people from Sams: Phil Kennedy, Wendy Ford, and Scott Arant.

For the second revised edition of this book, we'd like to thank Kathryn Purdum, our acquisitions editor, Charlotte Clapp, our project editor, and Geneil Breeze, our copy editor.

**Team LiB**

[◀ PREVIOUS](#)

[NEXT ▶](#)

# Chapter 2. A Quick Review of the Basics

## IN THIS CHAPTER

- [Some Basic Commands](#)
- [Working with Files](#)
- [Working with Directories](#)
- [Filename Substitution](#)
- [Standard Input/Output and I/O Redirection](#)
- [Pipes](#)
- [Standard Error](#)
- [More on Commands](#)
- [Command Summary](#)
- [Exercises](#)

This chapter provides a review of the Unix system, including the file system, basic commands, filename substitution, I/O redirection, and pipes.

## Some Basic Commands

### Displaying the Date and Time: The `date` Command

The `date` command tells the system to print the date and time:

```
$ date
```

```
Sat Jul 20 14:42:56 EDT 2002
```

```
$
```

`date` prints the day of the week, month, day, time (24-hour clock, the system's time zone), and year. Throughout this book, whenever we use **boldface type like this**, it's to indicate what you, the user, types in. *Normal face type like this* is used to indicate what the Unix system prints. *Italic type* is used for comments in interactive sequences.

Every Unix command is ended with the pressing of the Enter key. Enter says that you are finished typing things in and are ready for the Unix system to do its thing.

### Finding Out Who's Logged In: The `who` Command

The `who` command can be used to get information about all users currently logged in to the system:

```
$ who
```

```
pat      tty29    Jul 19 14:40
```

```
ruth     tty37    Jul 19 10:54
```

```
steve    tty25    Jul 19 15:52
```

```
$
```

Here, three users are logged in: `pat`, `ruth`, and `steve`. Along with each user id, the `tty` number of that user and the day and time that user logged in is listed. The `tty` number is a unique identification number the Unix system gives to each terminal or network device that a user has logged into.

The `who` command also can be used to get information about yourself:

```
$ who am i
pat          tty29    Jul 19 14:40
$
```

`who` and `who am i` are actually the same command: `who`. In the latter case, the `am` and `i` are *arguments* to the `who` command.

## Echoing Characters: The `echo` Command

The `echo` command prints (or *echoes*) at the terminal whatever else you happen to type on the line (there are some exceptions to this that you'll learn about later):

```
$ echo this is a test
this is a test
$ echo why not print out a longer line with echo?
why not print out a longer line with echo?
$ echo
```

*A blank line is displayed*

```
$ echo one          two   three          four   five
one two three four five
$
```

You will notice from the preceding example that `echo` squeezes out extra blanks between words. That's because on a Unix system, the words are important; the blanks are merely there to separate the words. Generally, the Unix system ignores extra blanks (you'll learn more about this in the next chapter).

Team LiB

◀ PREVIOUS

NEXT ▶



## Working with Files

The Unix system recognizes only three basic types of files: *ordinary* files, *directory* files, and *special* files. An ordinary file is just that: any file on the system that contains data, text, program instructions, or just about anything else. Directories are described later in this chapter. As its name implies, a special file has a special meaning to the Unix system and is typically associated with some form of I/O.

A filename can be composed of just about any character directly available from the keyboard (and even some that aren't) provided that the total number of characters contained in the name is not greater than 255. If more than 255 characters are specified, the Unix system simply ignores the extra characters.<sup>[1]</sup>

<sup>[1]</sup> *Modern Unix and Microsoft Windows systems support long filenames; however, some older Unix and Windows systems only allow much shorter filenames.*

The Unix system provides many tools that make working with files easy. Here we'll review many basic file manipulation commands.

### Listing Files: The `ls` Command

To see what files you have stored in your directory, you can type the `ls` command:

```
$ ls
READ_ME
names
tmp
$
```

This output indicates that three files called `READ_ME`, `names`, and `tmp` are contained in the current directory. (Note that the output of `ls` may vary from system to system. For example, on many Unix systems `ls` produces multicolumn output when sending its output to a terminal; on others, different colors may be used for different types of files. You can always force single-column output with the `-l` option.)

### Displaying the Contents of a File: The `cat` Command

You can examine the *contents* of a file by using the `cat` command. The argument to `cat` is the name of the file whose contents you want to examine.

```
$ cat names
```

```
Susan
```

```
Jeff
```

```
Henry
```

```
Allan
```

```
Ken
```

```
$
```

## Counting the Number of Words in a File: The `wc` Command

With the `wc` command, you can get a count of the total number of lines, words, and characters of information contained in a file. Once again, the name of the file is needed as the argument to this command:

```
$ wc names
```

```
5      5      27 names
```

```
$
```

The `wc` command lists three numbers followed by the filename. The first number represents the number of lines contained in the file (5), the second the number of words contained in the file (in this case also 5), and the third the number of characters contained in the file (27).

## Command Options

Most Unix commands allow the specification of *options* at the time a command is executed. These options generally follow the same format:

```
-letter
```

That is, a command option is a minus sign followed immediately by a single letter. For example, to count just the number of lines contained in a file, the option `-l` (that's the letter l) is given to the `wc` command:

```
$ wc -l names
      5 names
$
```

To count just the number of characters in a file, the `-c` option is specified:

```
$ wc -c names
     27 names
$
```

Finally, the `-w` option can be used to count the number of words contained in the file:

```
$ wc -w names
      5 names
$
```

Some commands require that the options be listed before the filename arguments. For example, `sort names -r` is acceptable, whereas `wc names -l` is not. Let's generalize by saying that command options should *precede* filenames on the command line.

## Making a Copy of a File: The `cp` Command

To make a copy of a file, the `cp` command is used. The first argument to the command is the name of the file to be copied (known as the *source file*), and the second argument is the name of the file to place the copy into (known as the *destination file*). You can make a copy of the file `names` and call it `saved_names` as follows:

```
$ cp names saved_names
```

```
$
```

Execution of this command causes the file named `names` to be copied into a file named `saved_names`. As with many Unix commands, the fact that a command prompt was displayed after the `cp` command was typed indicates that the command executed successfully.

## Renaming a File: The `mv` Command

A file can be renamed with the `mv` command. The arguments to the `mv` command follow the same format as the `cp` command. The first argument is the name of the file to be renamed, and the second argument is the new name. So, to change the name of the file `saved_names` to `hold_it`, for example, the following command would do the trick:

```
$ mv saved_names hold_it
```

```
$
```

When executing an `mv` or `cp` command, the Unix system does not care whether the file specified as the second argument already exists. If it does, the contents of the file will be lost.<sup>[2]</sup> For example, if a file called `old_names` exists, executing the command

<sup>[2]</sup> *Assuming that you have the proper permission to write to the file.*

```
cp names old_names
```

would copy the file `names` to `old_names`, destroying the previous contents of `old_names` in the process. Similarly, the command

```
mv names old_names
```

would rename `names` to `old_names`, even if the file `old_names` existed prior to execution of the command.

## Removing a File: The `rm` Command

To remove a file from the system, you use the `rm` command. The argument to `rm` is simply the name of the file to be removed:

```
$ rm hold_it
```

```
$
```

You can remove more than one file at a time with the `rm` command by simply specifying all such files on the command line. For example, the following would remove the three files `wb`, `collect`, and `mon`:

```
$ rm wb collect mon
```

```
$
```

## Working with Directories

Suppose that you had a set of files consisting of various memos, proposals, and letters. Further suppose that you had a set of files that were computer programs. It would seem logical to group this first set of files into a directory called `documents`, for example, and the latter set of files into a directory called `programs`. [Figure 2.1](#) illustrates such a directory organization.

Figure 2.1. Example directory structure.

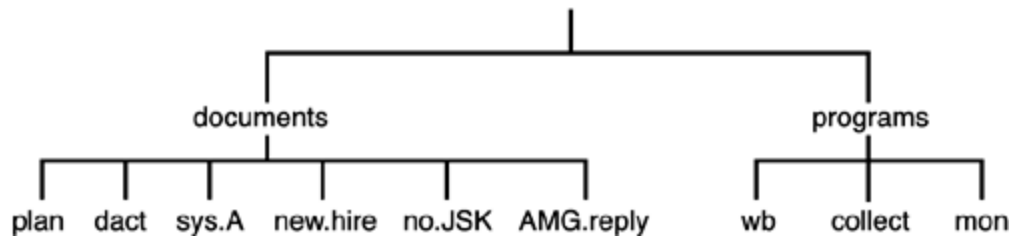

The file directory `documents` contains the files `plan`, `dact`, `sys.A`, `new.hire`, `no.JSK`, and `AMG.reply`. The directory `programs` contains the files `wb`, `collect`, and `mon`. At some point, you may decide to further categorize the files in a directory. This can be done by creating subdirectories and then placing each file into the appropriate subdirectory. For example, you might want to create subdirectories called `memos`, `proposals`, and `letters` inside your `documents` directory, as shown in [Figure 2.2](#).

Figure 2.2. Directories containing subdirectories.

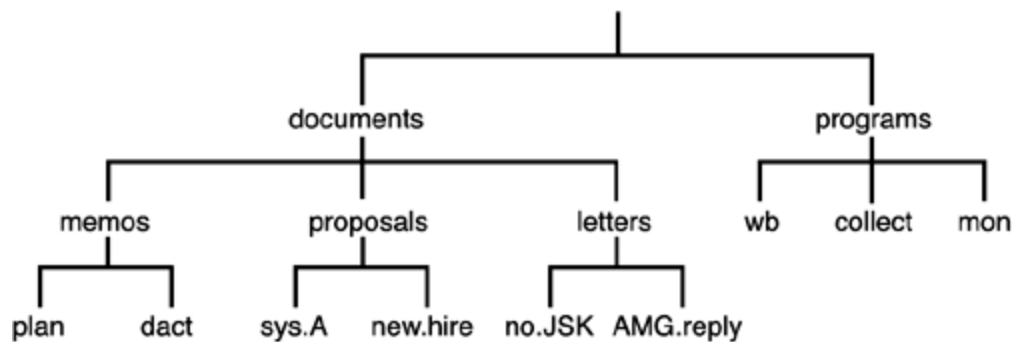

`documents` contains the subdirectories `memos`, `proposals`, and `letters`. Each of these directories in turn contains two files: `memos` contains `plan` and `dact`; `proposals` contains `sys.A` and `new.hire`; and `letters` contains `no.JSK` and `AMG.reply`.

Although each file in a given directory must have a unique name, files contained in different directories do not. So, for example, you could have a file in your `programs` directory called `dact`, even though a file by that name also exists in the `memos` subdirectory.

## The Home Directory and Pathnames

The Unix system always associates each user of the system with a particular directory. When you log in to the system, you are placed automatically into a directory called your *home* directory.

Although the location of users' home directories can vary from one Unix version to the next, and even one user to the next, let's assume that your home directory is called `steve` and that this directory is actually a subdirectory of a directory called `users`. Therefore, if you had the directories `documents` and `programs`, the overall directory structure would actually look something like [Figure 2.3](#). A special directory known as `/` (pronounced *slash*) is shown at the top of the directory tree. This directory is known as the *root*.

Figure 2.3. Hierarchical directory structure.

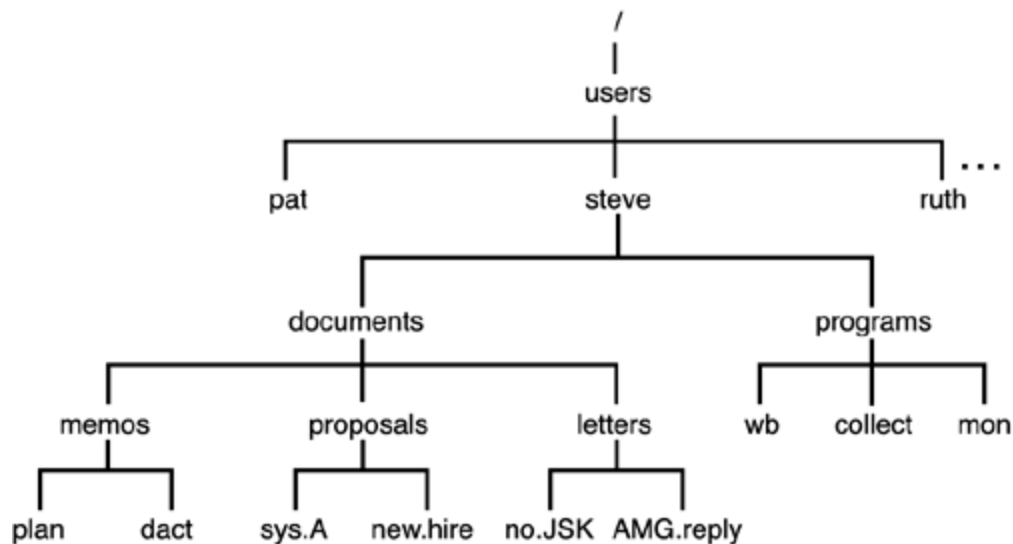

Whenever you are "inside" a particular directory (called your *current working* directory), the files contained within that directory are immediately accessible. If you want to access a file from another directory, you can either first issue a command to "change" to the appropriate directory and then access the particular file, or you can specify the particular file by its pathname.

A pathname enables you to uniquely identify a particular file to the Unix system. In the specification of a pathname, successive directories along the path are separated by the slash character `/`. A pathname that *begins* with a slash character is known as a *full* pathname because it specifies a complete path from the root. So, for example, the pathname `/users/steve` identifies the directory `steve` contained under the directory `users`. Similarly, the pathname `/users/steve/documents` references the directory `documents` as contained in the directory `steve` under `users`. As a final example, the pathname `/users/steve/documents/letters/AMG.reply` identifies the file `AMG.reply` contained along the appropriate directory path.

To help reduce some of the typing that would otherwise be required, Unix provides certain notational conveniences. Pathnames that do not begin with a slash character are known as *relative* pathnames. The path is relative to your current working directory. For example, if you just logged in to the system and were placed into your home directory `/users/steve`, you could directly reference the directory `documents` simply by typing `documents`. Similarly, the relative pathname `programs/mon`

could be typed to access the file `mon` contained inside your `programs` directory.

By convention, the directory name `..` always references the directory that is one level higher. For example, after logging in and being placed into your home directory `/users/steve`, the pathname `..` would reference the directory `users`. And if you had issued the appropriate command to change your working directory to `documents/letters`, the pathname `..` would reference the `documents` directory, `../..` would reference the directory `steve`, and `../proposals/new.hire` would reference the file `new.hire` contained in the `proposals` directory. Note that in this case, as in most cases, there is usually more than one way to specify a path to a particular file.

Another notational convention is the single period `.`, which always refers to the current directory.

Now it's time to examine commands designed for working with directories.

## Displaying Your Working Directory: The `pwd` Command

The `pwd` command is used to help you "get your bearings" by telling you the name of your current working directory.

Recall the directory structure from [Figure 2.3](#). The directory that you are placed in after you log in to the system is called your home directory. You can assume from [Figure 2.3](#) that the home directory for the user `steve` is `/users/steve`. Therefore, whenever `steve` logs in to the system, he will automatically be placed inside this directory. To verify that this is the case, the `pwd` (print working directory) command can be issued:

```
$ pwd
/users/steve
$
```

The output from the command verifies that `steve's` current working directory is `/users/steve`.

## Changing Directories: The `cd` Command

You can change your current working directory by using the `cd` command. This command takes as its argument the name of the directory you want to change to.

Let's assume that you just logged in to the system and were placed inside your home directory, `/users/steve`. This is depicted by the arrow in [Figure 2.4](#).

Figure 2.4. Current working directory is `steve`.



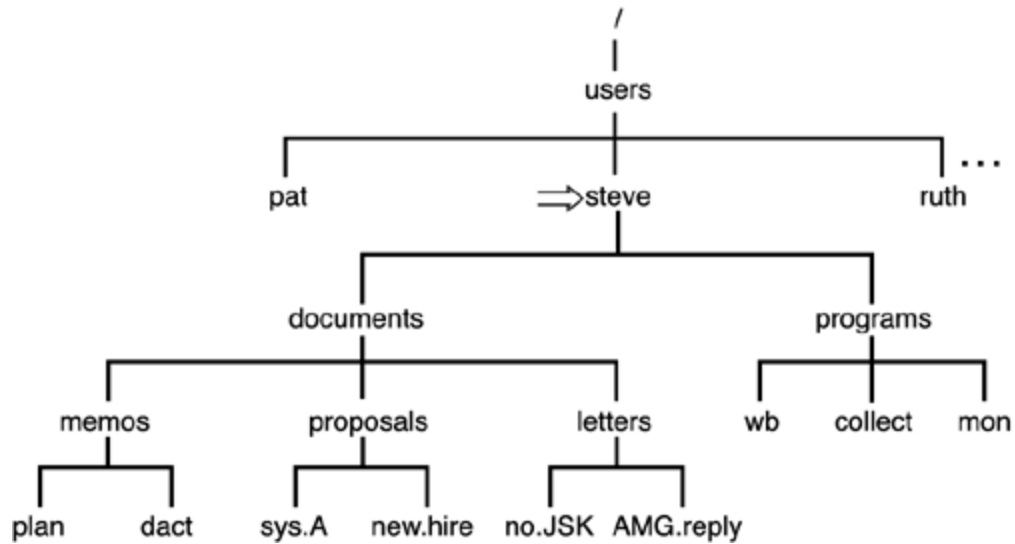

You know that two directories are directly "below" `steve`'s home directory: `documents` and `programs`. In fact, this can be verified at the terminal by issuing the `ls` command:

```
$ ls
documents
programs
$
```

The `ls` command lists the two directories `documents` and `programs` the same way it listed other ordinary files in previous examples.

To change your current working directory, issue the `cd` command, followed by the name of the directory to change to:

```
$ cd documents
$
```

After executing this command, you will be placed inside the `documents` directory, as depicted in [Figure 2.5](#).

Figure 2.5. `cd documents`.

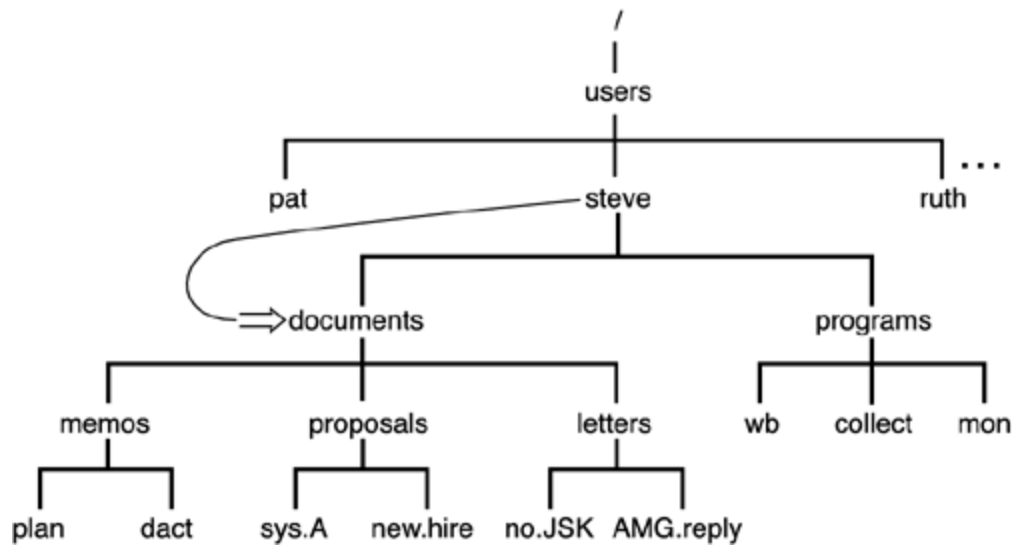

You can verify at the terminal that the working directory has been changed by issuing the `pwd` command:

```

$ pwd
/users/steve/documents
$

```

The easiest way to get one level up in a directory is to issue the command

```
cd ..
```

because by convention `..` always refers to the directory one level up (known as the *parent* directory; see [Figure 2.6](#)).

```

$ cd ..
$ pwd
/users/steve
$

```

Figure 2.6. `cd ..`

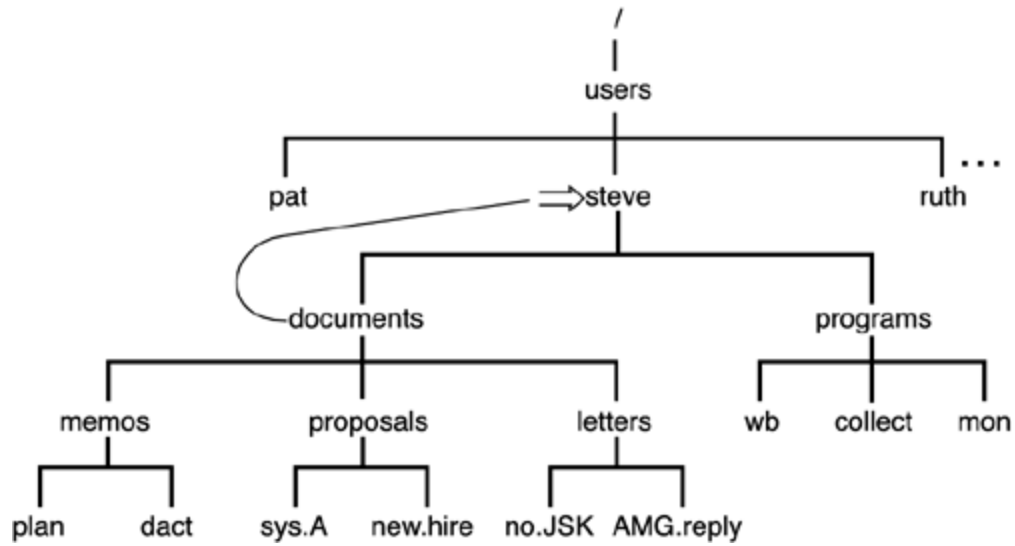

If you wanted to change to the `letters` directory, you could get there with a single `cd` command by specifying the relative path `documents/letters` (see [Figure 2.7](#)):

```
$ cd documents/letters
$ pwd
/users/steve/documents/letters
$
```

Figure 2.7. `cd documents/letters`.

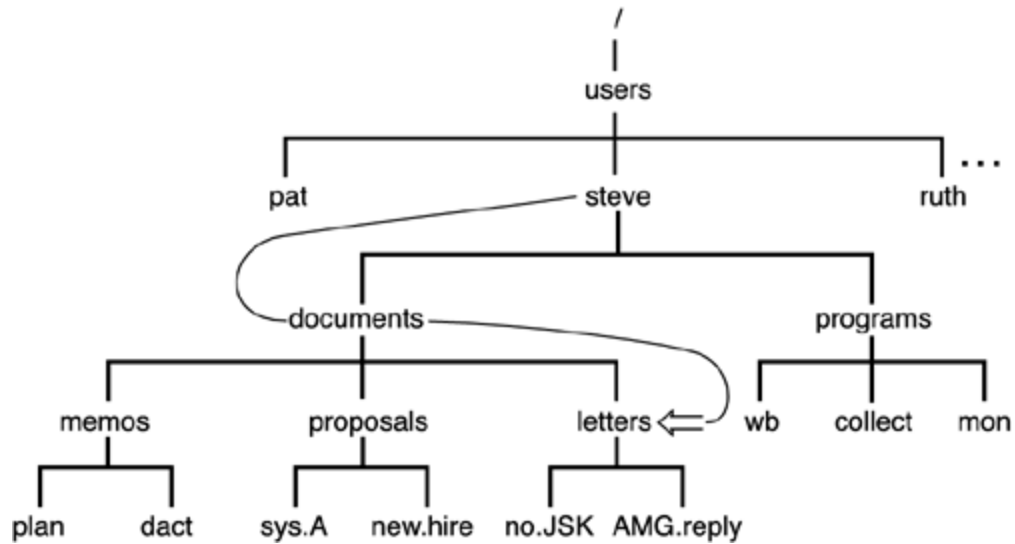

You can get back up to the home directory by using a single `cd` command to go up two directories as shown:

```

$ cd ../../
$ pwd
/users/steve
$

```

Or you can get back to the home directory using a full pathname rather than a relative one:

```

$ cd /users/steve
$ pwd
/users/steve
$

```

Finally, there is a third way to get back to the home directory that is also the easiest. Typing the command `cd` *without* an argument *always* places you back into your home directory, no matter where you are in your directory path:

```
$ cd
```

```
$ pwd
```

```
/users/steve
```

```
$
```

## More on the `ls` Command

When you type the `ls` command, the files contained in the current working directory are listed. But you can also use `ls` to obtain a list of files in other directories by supplying an argument to the command. First let's get back to your home directory:

```
$ cd
```

```
$ pwd
```

```
/users/steve
```

```
$
```

Now let's take a look at the files in the current working directory:

```
$ ls
```

```
documents
```

```
programs
```

```
$
```

If you supply the name of one of these directories to the `ls` command, you can get a list of the contents of that directory. So, you can find out what's contained in the `documents` directory simply by typing the command `ls documents`:

```
$ ls documents
```

```
letters
```

```
memos
```

```
proposals
```

```
$
```

To take a look at the subdirectory `memos`, you follow a similar procedure:

```
$ ls documents/memos
```

```
dact
```

```
plan
```

```
$
```

If you specify a nondirectory file argument to the `ls` command, you simply get that filename echoed back at the terminal:

```
$ ls documents/memos/plan
```

```
documents/memos/plan
```

```
$
```

An option to the `ls` command enables you to determine whether a particular file is a directory, among other things. The `-l` option (the letter `l`) provides a more detailed description of the files in a directory. If you were currently in `steve`'s home directory as indicated in [Figure 2.6](#), the following would illustrate the effect of supplying the `-l` option to the `ls` command:

```
$ ls -l
```

```
total 2
```

```
drwxr-xr-x  5 steve  DP3725   80 Jun 25 13:27 documents
```

```
drwxr-xr-x  2 steve  DP3725   96 Jun 25 13:31 programs
```

```
$
```

The first line of the display is a count of the total number of *blocks* (1,024 bytes) of storage that the listed files use. Each successive line displayed by the `ls -l` command contains detailed information about a file in the directory. The first character on each line tells whether the file is a directory. If the character is `d`, it is a directory; if it is `-`, it is an ordinary file; finally, if it is `b`, `c`, `l`, or `p`, it is a special file.

The next nine characters on the line tell how every user on the system can access the *particular* file. These *access modes* apply to the file's owner (the first three characters), other users in the same *group* as the file's owner (the next three characters), and finally to all other users on the system (the last three characters). They tell whether the user can read from the file, write to the file, or execute the contents of the file.

The `ls -l` command lists the *link* count (see "[Linking Files: The ln Command](#)," later in this chapter), the owner of the file, the group owner of the file, how large the file is (that is, how many characters are contained in it), and when the file was last modified. The information displayed last on the line is the filename itself.

```
$ ls -l programs
total 4
-rwxr-xr-x  1 steve  DP3725    358 Jun 25 13:31 collect
-rwxr-xr-x  1 steve  DP3725   1219 Jun 25 13:31 mon
-rwxr-xr-x  1 steve  DP3725    89 Jun 25 13:30 wb
$
```

The dash in the first column of each line indicates that the three files `collect`, `mon`, and `wb` are ordinary files and not directories.

## Creating a Directory: The `mkdir` Command

To create a directory, the `mkdir` command must be used. The argument to this command is simply the name of the directory you want to make. For example, assume that you are still working with the directory structure depicted in [Figure 2.7](#) and that you want to create a new directory called `misc` *on the same level* as the directories `documents` and `programs`. If you were currently in your home directory, typing the command `mkdir misc` would achieve the desired effect:

```
$ mkdir misc
$
```

Now if you execute an `ls` command, you should get the new directory listed:

```
$ ls
documents
misc
programs
$
```

The directory structure now appears as shown in [Figure 2.8](#).

Figure 2.8. Directory structure with newly created `misc` directory.

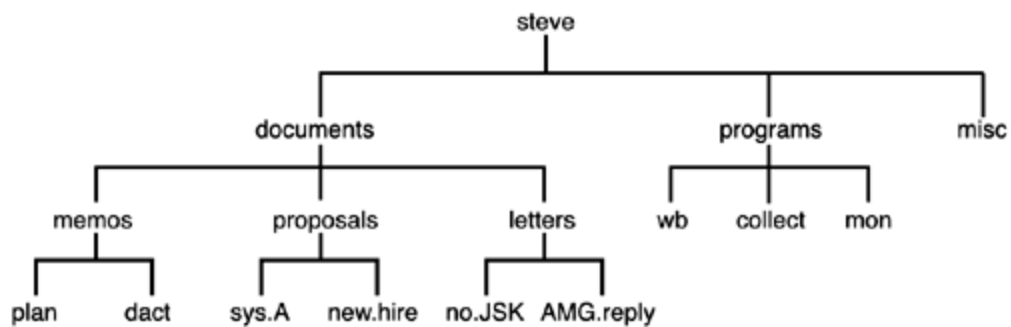

## Copying a File from One Directory to Another

The `cp` command can be used to copy a file from one directory into another. For example, you can copy the file `wb` from the `programs` directory into a file called `wbx` in the `misc` directory as follows:

```
$ cp programs/wb misc/wbx
$
```

Because the two files are contained in different directories, it is not even necessary that they be given different names:



```
$ cp programs/wb misc/wb
```

```
$
```

When the destination file has the same name as the source file (in a different directory, of course), it is necessary to specify only the destination directory as the second argument:

```
$ cp programs/wb misc
```

```
$
```

When this command gets executed, the Unix system recognizes that the second argument is the name of a directory and copies the source file into that directory. The new file is given the same name as the source file. You can copy more than one file into a directory by listing the files to be copied before the name of the destination directory. If you were currently in the `programs` directory, the command

```
$ cp wb collect mon ../misc
```

```
$
```

would copy the three files `wb`, `collect`, and `mon` into the `misc` directory, under the same names.

To copy a file from another directory into your current one and give it the same name, use the fact that the current directory can always be referenced as `'.'`:

```
$ pwd
```

```
/users/steve/misc
```

```
$ cp ../programs/collect .
```

```
$
```

The preceding command copies the file `collect` from the directory `../programs` into the current directory (`/users/steve/misc`).

## Moving Files Between Directories

You recall that the `mv` command can be used to rename a file. However, when the two arguments to this command reference different directories, the file is actually moved from the first directory into the second directory. For example, first change from the home directory to the `documents` directory:

```
$ cd documents
```

```
$
```

Suppose that now you decide that the file `plan` contained in the `memos` directory is really a proposal and not a memo. So you want to move it from the `memos` directory into the `proposals` directory. The following would do the trick:

```
$ mv memos/plan proposals/plan
```

```
$
```

As with the `cp` command, if the source file and destination file have the same name, only the name of the destination directory need be supplied.

```
$ mv memos/plan proposals
```

```
$
```

Also like the `cp` command, a group of files can be simultaneously moved into a directory by simply listing all files to be moved before the name of the destination directory:

```
$ pwd
```

```
/users/steve/programs
```

```
$ mv wb collect mon ../misc
```

```
$
```

This would move the three files `wb`, `collect`, and `mon` into the directory `misc`. You can also use the `mv` command to change the name of a directory. For example, the following renames the directory `programs` to `bin`.

```
$ mv programs bin
```

```
$
```

## Linking Files: The `ln` Command

In simplest terms, the `ln` command provides an easy way for you to give more than one name to a file. The general form of the command is

```
ln from to
```

This links the file *from* to the file *to*.

Recall the structure of `steve`'s `programs` directory from [Figure 2.8](#). In that directory, he has stored a program called `wb`. Suppose that he decides that he'd also like to call the program `writeback`. The most obvious thing to do would be to simply create a copy of `wb` called `writeback`:

```
$ cp wb writeback
```

```
$
```

The drawback with this approach is that now twice as much disk space is being consumed by the program. Furthermore, if `steve` ever changes `wb`, he may forget to make a new copy of `writeback`, resulting in two different copies of what he thinks is the same program.

By linking the file `wb` to the new name, these problems are avoided:

```
$ ln wb writeback
```

```
$
```

Now instead of two copies of the file existing, only one exists with two different names: `wb` and

`writeback`. The two files have been logically linked by the Unix system. As far as you're concerned, it appears as though you have two *different* files. Executing an `ls` command shows the two files separately:

```
$ ls
collect
mon
wb
writeback
$
```

Look what happens when you execute an `ls -l`:

```
$ ls -l
total 5
-rwxr-xr-x  1 steve  DP3725   358 Jun 25 13:31 collect
-rwxr-xr-x  1 steve  DP3725  1219 Jun 25 13:31 mon
-rwxr-xr-x  2 steve  DP3725    89 Jun 25 13:30 wb
-rwxr-xr-x  2 steve  DP3725    89 Jun 25 13:30 writeback
$
```

The number right before `steve` is 1 for `collect` and `mon` and 2 for `wb` and `writeback`. This number is the number of links to a file, normally 1 for nonlinked, nondirectory files. Because `wb` and `writeback` are linked, this number is 2 for these files. This implies that you can link to a file more than once.

You can remove either of the two linked files at any time, and the other will not be removed:

```
$ rm writeback
$ ls -l
total 4
```

```

-rwxr-xr-x  1 steve  DP3725    358 Jun 25 13:31 collect
-rwxr-xr-x  1 steve  DP3725   1219 Jun 25 13:31 mon
-rwxr-xr-x  1 steve  DP3725    89 Jun 25 13:30 wb
$

```

Note that the number of links on `wb` went from 2 to 1 because one of its links was removed.

Most often, `ln` is used to link files between directories. For example, suppose that `pat` wanted to have access to `steve's wb` program. Instead of making a copy for himself (subject to the same problems described previously) or including `steve's programs` directory in his `PATH` (described in detail in [Chapter 11](#), "Your Environment"), he can simply link to the file from his own program directory; for example:

```

$ pwd

/users/pat/bin                pat's program directory

$ ls -l

total 4

-rwxr-xr-x  1 pat      DP3822   1358 Jan 15 11:01 lcat
-rwxr-xr-x  1 pat      DP3822    504 Apr 21 18:30 xtr

$ ln /users/steve/wb .      link wb to pat's bin

$ ls -l

total 5

-rwxr-xr-x  1 pat      DP3822   1358 Jan 15 11:01 lcat
-rwxr-xr-x  2 steve    DP3725    89 Jun 25 13:30 wb
-rwxr-xr-x  1 pat      DP3822    504 Apr 21 18:30 xtr

$

```

Note that `steve` is still listed as the owner of `wb`, even though the listing came from `pat's` directory. This makes sense, because really only one copy of the file exists—and it's owned by `steve`.

The only stipulation on linking files is that for ordinary links, the files to be linked together must reside on the same *file system*. If they don't, you'll get an error from `ln` when you try to link them. (To determine the different file systems on your system, execute the `df` command. The first field on each line of output is the name of a file system.)

To create links to files on different file systems (or perhaps on different networked systems), you can use the `-s` option to the `ln` command. This creates a *symbolic* link. Symbolic links behave a lot like regular links, except that the symbolic link points to the original file; if the original file is removed, the symbolic link no longer works. Let's see how symbolic links work with the previous example:

```
$ rm wb

$ ls -l

total 4

-rwxr-xr-x  1 pat      DP3822   1358 Jan 15 11:01 lcat
-rwxr-xr-x  1 pat      DP3822    504 Apr 21 18:30 xtr

$ ln -s /users/steve/wb ./symwb  Symbolic link to wb

$ ls -l

total 5

-rwxr-xr-x  1 pat      DP3822   1358 Jan 15 11:01 lcat
lrwxr-xr-x  1 pat      DP3822    15 Jul 20 15:22 symwb -> /users/steve/wb
-rwxr-xr-x  1 pat      DP3822    504 Apr 21 18:30 xtr

$
```

Note that `pat` is listed as the owner of `symwb`, and the file type is `l`, which indicates a symbolic link. The size of the symbolic link is 15 (the file actually contains the string `/users/steve/wb`), but if we attempt to access the contents of the file, we are presented with the contents of its symbolic link, `/users/steve/wb`:

```
$ wc symwb

      5      9      89 symwb

$
```

The `-L` option to the `ls` command can be used with the `-l` option to get a detailed list of information on the file the symbolic link points to:

```
$ ls -Ll
total 5
-rwxr-xr-x  1 pat      DP3822   1358 Jan 15 11:01 lcat
-rwxr-xr-x  2 steve   DP3725     89 Jun 25 13:30 wb
-rwxr-xr-x  1 pat      DP3822    504 Apr 21 18:30 xtr
$
```

Removing the file that a symbolic link points to invalidates the symbolic link (because symbolic links are maintained as filenames), although the symbolic link continues to stick around:

```
$ rm /users/steve/wb    Assume pat can remove this file
$ ls -l
total 5
-rwxr-xr-x  1 pat      DP3822   1358 Jan 15 11:01 lcat
lrwxr-xr-x  1 pat      DP3822    15 Jul 20 15:22 wb -> /users/steve/wb
-rwxr-xr-x  1 pat      DP3822    504 Apr 21 18:30 xtr
$ wc wb
Cannot open wb: No such file or directory
$
```

This type of file is called a *dangling symbolic link* and should be removed unless you have a specific reason to keep it around (for example, if you intend to replace the removed file).

One last note before leaving this discussion: The `ln` command follows the same general format as `cp` and `mv`, meaning that you can link a bunch of files at once into a directory using the format

*ln files directory*

## Removing a Directory: The `rmdir` Command

You can remove a directory with the `rmdir` command. The stipulation involved in removing a directory is that no files be contained in the directory. If there *are* files in the directory when `rmdir` is executed, you will not be allowed to remove the directory. To remove the directory `misc` that you created earlier, the following could be used:

```
$ rmdir /users/steve/misc
```

```
$
```

Once again, the preceding command works only if no files are contained in the `misc` directory; otherwise, the following happens:

```
$ rmdir /users/steve/misc
```

```
rmdir: /users/steve/misc not empty
```

```
$
```

If this happens and you still want to remove the `misc` directory, you would first have to remove all the files contained in that directory before reissuing the `rmdir` command.

As an alternate method for removing a directory and the files contained in it, you can use the `-r` option to the `rm` command. The format is simple:

```
rm -r dir
```

where *dir* is the name of the directory that you want to remove. `rm` removes the indicated directory and *all* files (including directories) in it.



# Filename Substitution

## The Asterisk

One powerful feature of the Unix system that is actually handled by the shell is *filename substitution*. Let's say that your current directory has these files in it:

```
$ ls
chapt1
chapt2
chapt3
chapt4
$
```

Suppose that you want to print their contents at the terminal. Well, you could take advantage of the fact that the `cat` command allows you to specify more than one filename at a time. When this is done, the contents of the files are displayed one after the other:

```
$ cat chapt1 chapt2 chapt3 chapt4
...
$
```

But you can also type in

```
$ cat *
...
$
```

and get the same results. The shell automatically *substitutes* the names of all the files in the current directory for the `*`. The same substitution occurs if you use `*` with the `echo` command:

```
$ echo *  
chapt1 chapt2 chapt3 chapt4  
$
```

Here the `*` is again replaced with the names of all the files contained in the current directory, and the `echo` command simply displays them at the terminal.

Anyplace that `*` appears on the command line, the shell performs its substitution:

```
$ echo * : *  
chapt1 chapt2 chapt3 chapt4 : chapt1 chapt2 chapt3 chapt4  
$
```

The `*` can also be used in combination with other characters to limit the filenames that are substituted. For example, let's say that in your current directory you have not only `chapt1` through `chapt4` but also files `a`, `b`, and `c`:

```
$ ls  
a  
b  
c  
chapt1  
chapt2  
chapt3  
chapt4  
$
```

To display the contents of just the files beginning with `chapt`, you can type in

```
$ cat chapt*  
  
.  
  
.  
  
.  
  
$
```

The `chapt*` matches any filename that *begins* with `chapt`. All such filenames matched are substituted on the command line.

The `*` is not limited to the end of a filename; it can be used at the beginning or in the middle as well:

```
$ echo *t1  
  
chapt1  
  
$ echo *t*  
  
chapt1 chapt2 chapt3 chapt4  
  
$ echo *x  
  
*x  
  
$
```

In the first `echo`, the `*t1` specifies all filenames that end in the characters `t1`. In the second `echo`, the first `*` matches everything up to a `t` and the second everything after; thus, all filenames containing a `t` are printed. Because there are no files ending with `x`, no substitution occurs in the last case. Therefore, the `echo` command simply displays `*x`.

## Matching Single Characters

The asterisk (`*`) matches *zero* or more characters, meaning that `x*` matches the file `x` as well as `x1`, `x2`, `xabc`, and so on. The question mark (`?`) matches exactly one character. So `cat ?` prints all files

with one-character names, just as `cat x?` prints all files with two-character names beginning with `x`.

```
$ ls
```

```
a
```

```
aa
```

```
aax
```

```
alice
```

```
b
```

```
bb
```

```
c
```

```
cc
```

```
report1
```

```
report2
```

```
report3
```

```
$ echo ?
```

```
a b c
```

```
$ echo a?
```

```
aa
```

```
$ echo ??
```

```
aa bb cc
```

```
$ echo ??*
```

```
aa aax alice bb cc report1 report2 report3
```

```
$
```

In the preceding example, the `??` matches two characters, and the `*` matches zero or more up to the end. The net effect is to match all filenames of two or more characters.

Another way to match a single character is to give a list of the characters to use in the match inside

square brackets `[ ]`. For example, `[abc]` matches *one* letter `a`, `b`, or `c`. It's similar to the `?`, but it allows you to choose the characters that will be matched. The specification `[0-9]` matches the characters `0 through 9`. The only restriction in specifying a *range* of characters is that the first character must be alphabetically less than the last character, so that `[z-f]` is not a valid range specification.

By mixing and matching ranges and characters in the list, you can perform some complicated substitutions. For example, `[a-np-z]*` matches all files that start with the letters `a` through `n` *or* `p` through `z` (or more simply stated, any lowercase letter but `o`).

If the first character following the `[` is a `!`, the sense of the match is inverted. That is, any character is matched *except* those enclosed in the brackets. So

```
[!a-z]
```

matches any character except a lowercase letter, and

```
*[!o]
```

matches any file that doesn't end with the lowercase letter `o`.

[Table 2.1](#) gives a few more examples of filename substitution.

## Table 2.1. Filename Substitution Examples

Command	Description
<code>echo a*</code>	Print the <i>names</i> of the files beginning with <code>a</code>
<code>cat *.c</code>	Print all files ending in <code>.c</code>
<code>rm *.*</code>	Remove all files containing a period
<code>ls x*</code>	List the names of all files beginning with <code>x</code>
<code>rm *</code>	Remove <i>all</i> files in the current directory (Note: Be careful when you use this.)
<code>echo a*b</code>	Print the names of all files beginning with <code>a</code> and ending with <code>b</code>
<code>cp ../programs/* .</code>	Copy all files from <code>../programs</code> into the current directory
<code>ls [a-z]*[!0-9]</code>	List files that begin with a lowercase letter and don't end with a digit

# Standard Input/Output and I/O Redirection

## Standard Input and Standard Output

Most Unix system commands take input from your terminal and send the resulting output back to your terminal. A command normally reads its input from a place called *standard input*, which happens to be your terminal by default. Similarly, a command normally writes its output to *standard output*, which is also your terminal by default. This concept is depicted in [Figure 2.9](#).

Figure 2.9. Typical Unix command.



Recall that executing the `who` command results in the display of the currently logged-in users. More formally, the `who` command writes a list of the logged-in users to standard output. This is depicted in [Figure 2.10](#).

Figure 2.10. `who` command.

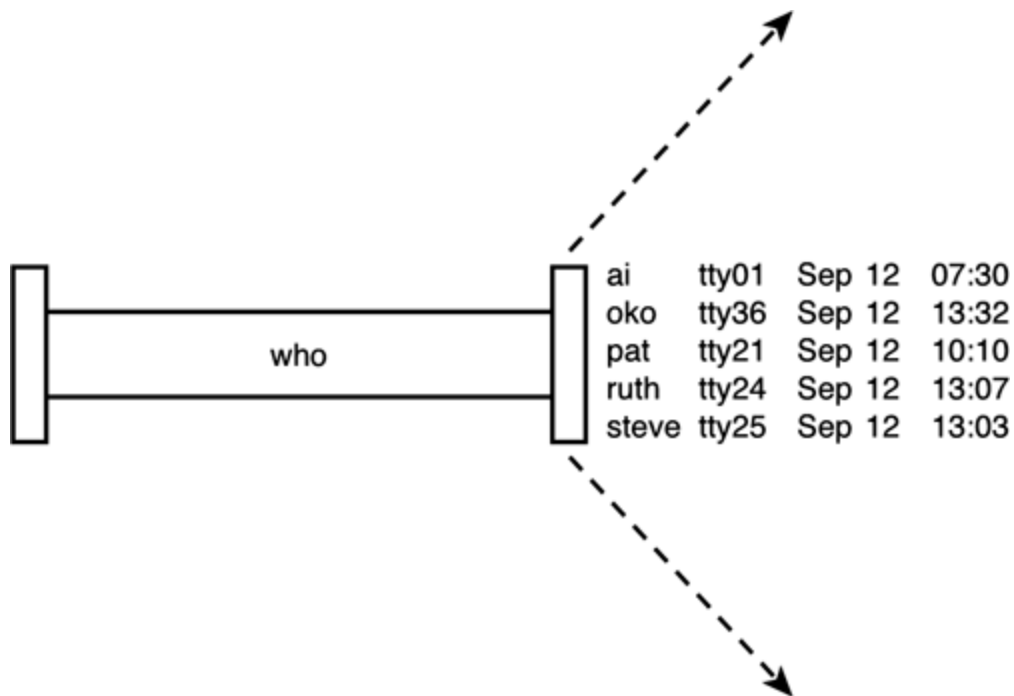

If a `sort` command is executed *without* a filename argument, the command takes its input from standard input. As with standard output, this is your terminal by default.

When entering data to a command from the terminal, the `Ctrl` and `d` keys (denoted `Ctrl+d` in this text) must be simultaneously pressed after the last data item has been entered. This tells the command that you have finished entering data. As an example, let's use the `sort` command to sort the following four names: Tony, Barbara, Harry, Dick. Instead of first entering the names into a file, we'll enter them directly from the terminal:

```
$ sort
Tony
Barbara
Harry
Dick
Ctrl+d
Barbara
Dick
Harry
Tony
$
```

Because no filename was specified to the `sort` command, the input was taken from standard input, the terminal. After the fourth name was typed in, the `Ctrl` and `d` keys were pressed to signal the end of the data. At that point, the `sort` command sorted the four names and displayed the results on the standard output device, which is also the terminal. This is depicted in [Figure 2.11](#).

Figure 2.11. `sort` command.

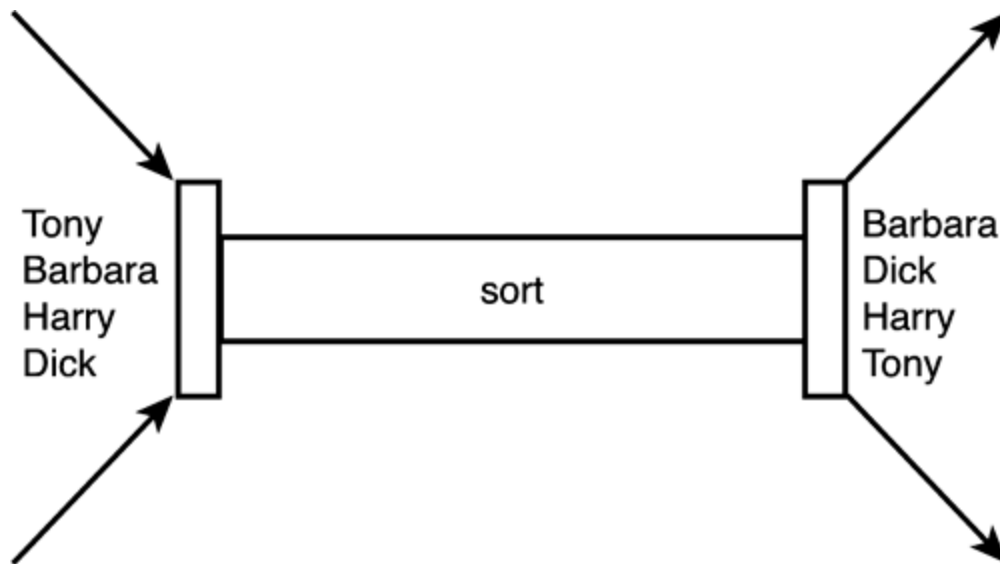

The `wc` command is another example of a command that takes its input from standard input if no filename is specified on the command line. So the following shows an example of this command used to count the number of lines of text entered from the terminal:

```
$ wc -l
```

```
This is text that
```

```
is typed on the
```

```
standard input device.
```

```
Ctrl+d
```

```
3
```

```
$
```

Note that the `Ctrl+d` that is used to terminate the input is not counted as a separate line by the `wc` command. Furthermore, because no filename was specified to the `wc` command, only the count of the number of lines (3) is listed as the output of the command. (Recall that this command normally prints the name of the file directly after the count.)

## Output Redirection

The output from a command normally intended for standard output can be easily diverted to a file instead. This capability is known as *output redirection*.



If the notation `> file` is appended to *any* command that normally writes its output to standard output, the output of that command will be written to *file* instead of your terminal:

```
$ who > users
```

```
$
```

This command line causes the `who` command to be executed and its output to be written into the file `users`. Notice that no output appears at the terminal. This is because the output has been *redirected* from the default standard output device (the terminal) into the specified file:

```
$ cat users
```

```
oko    tty01  Sep 12 07:30
```

```
ai     tty15  Sep 12 13:32
```

```
ruth   tty21  Sep 12 10:10
```

```
pat    tty24  Sep 12 13:07
```

```
steve  tty25  Sep 12 13:03
```

```
$
```

If a command has its output redirected to a file and the file already contains some data, that data will be lost. Consider this example:

```
$ echo line 1 > users
```

```
$ cat users
```

```
line 1
```

```
$ echo line 2 >> users
```

```
$ cat users
```

```
line 1
```

```
line 2
```

```
$
```

The second `echo` command uses a different type of output redirection indicated by the characters `>>`. This character pair causes the standard output from the command to be *appended* to the specified file. Therefore, the previous contents of the file are not lost, and the new output simply gets added onto the end.

By using the redirection append characters `>>`, you can use `cat` to append the contents of one file onto the end of another:

```
$ cat file1
This is in file1.
$ cat file2
This is in file2.
$ cat file1 >> file2    Append file1 to file2
$ cat file2
This is in file2.
This is in file1.
$
```

Recall that specifying more than one filename to `cat` results in the display of the first file followed immediately by the second file, and so on:

```
$ cat file1
This is in file1.
$ cat file2
This is in file2.
$ cat file1 file2
This is in file1.
This is in file2.
```

```
$ cat file1 file2 > file3 Redirect it instead
$ cat file3
This is in file1.
This is in file2.
$
```

Now you can see where the `cat` command gets its name: When used with more than one file, its effect is to *catenate* the files together.

Incidentally, the shell recognizes a special format of output redirection. If you type

```
> file
```

not preceded by a command, the shell creates an empty (that is, zero character length) *file* for you. If *file* previously exists, its contents will be lost.

## Input Redirection

Just as the output of a command can be redirected to a file, so can the input of a command be redirected from a file. And as the greater-than character `>` is used for output redirection, the less-than character `<` is used to redirect the input of a command. Of course, only commands that normally take their input from standard input can have their input redirected from a file in this manner.

To redirect the input of a command, you type the `<` character followed by the name of the file that the input is to be read from. So, for example, to count the number of lines in the file `users`, you know that you can execute the command `wc -l users`:

```
$ wc -l users
  2 users
$
```

Or, you can count the number of lines in the file by redirecting the standard input of the `wc` command from the file `users`:

```
$ wc -l < users
```

```
2
```

```
$
```

Note that there is a difference in the output produced by the two forms of the `wc` command. In the first case, the name of the file `users` is listed with the line count; in the second case, it is not. This points out the subtle distinction between the execution of the two commands. In the first case, `wc` knows that it is reading its input from the file `users`. In the second case, it only knows that it is reading its input from standard input. The shell redirects the input so that it comes from the file `users` and not the terminal (more about this in the next chapter). As far as `wc` is concerned, it doesn't know whether its input is coming from the terminal or from a file!

Team LiB

◀ PREVIOUS

NEXT ▶

## Pipes

As you will recall, the file `users` that was created previously contains a list of all the users currently logged in to the system. Because you know that there will be one line in the file for each user logged in to the system, you can easily determine the *number* of users logged in by simply counting the number of lines in the `users` file:

```
$ who > users
$ wc -l < users
      5
$
```

This output would indicate that currently five users were logged in. Now you have a command sequence you can use whenever you want to know how many users are logged in.

Another approach to determine the number of logged-in users bypasses the use of a file. The Unix system allows you to effectively connect two commands together. This connection is known as a *pipe*, and it enables you to take the output from one command and feed it directly into the input of another command. A pipe is effected by the character `|`, which is placed between the two commands. So to make a pipe between the `who` and `wc -l` commands, you simply type `who | wc -l`:

```
$ who | wc -l
      5
$
```

The pipe that is effected between these two commands is depicted in [Figure 2.12](#).

Figure 2.12. Pipeline process: `who | wc -l`.

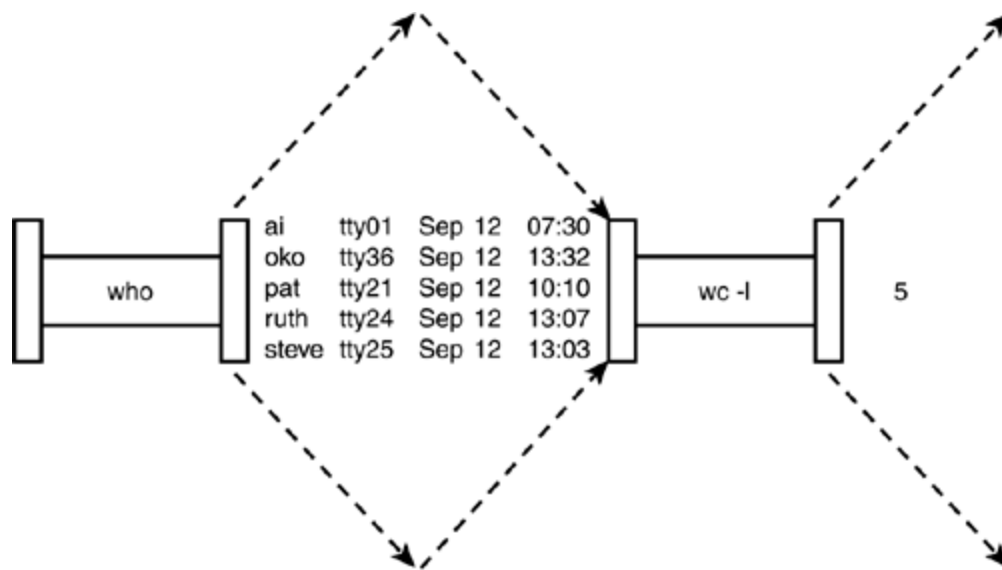

When a pipe is set up between two commands, the standard output from the first command is connected directly to the standard input of the second command. You know that the `who` command writes its list of logged-in users to standard output. Furthermore, you know that if no filename argument is specified to the `wc` command, it takes its input from standard input. Therefore, the list of logged-in users that is output from the `who` command automatically becomes the input to the `wc` command. Note that you never see the output of the `who` command at the terminal because it is piped directly into the `wc` command. This is depicted in [Figure 2.13](#).

Figure 2.13. Pipeline process.

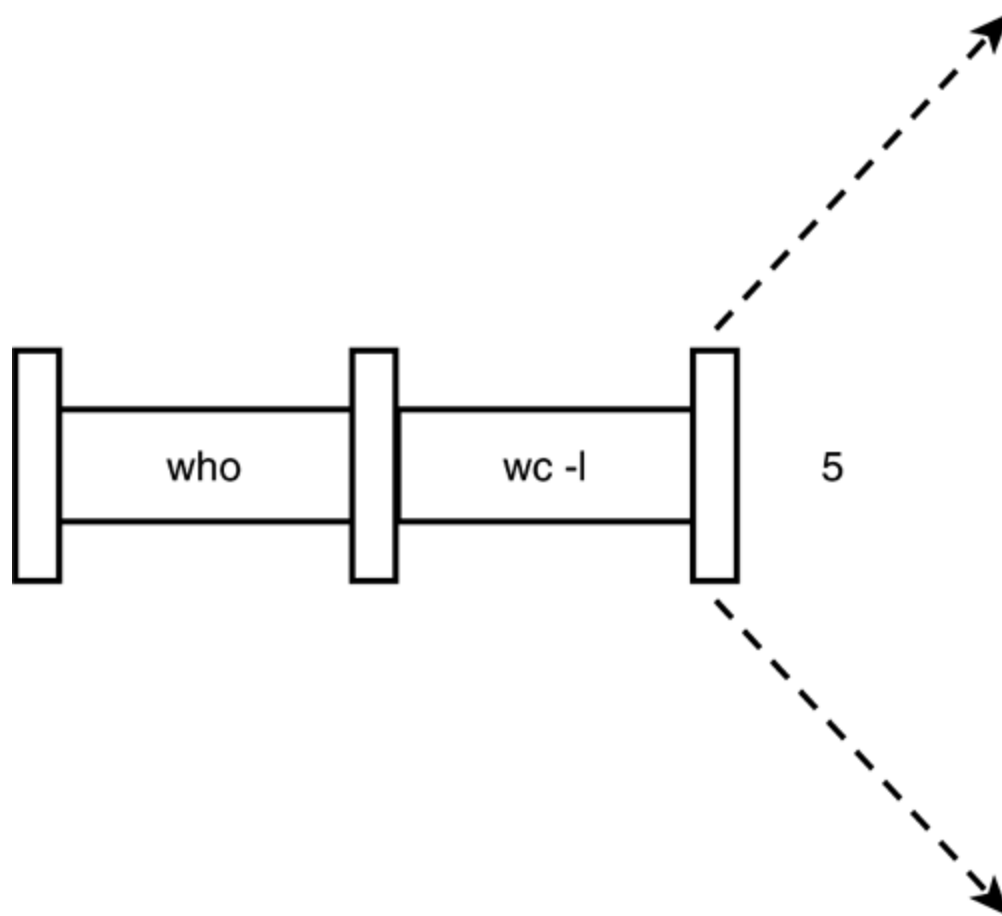

A pipe can be made between *any* two programs, provided that the first program writes its output to standard output, and the second program reads its input from standard input.

As another example of a pipe, suppose that you wanted to count the number of files contained in your directory. Knowledge of the fact that the `ls` command displays one line of output per file enables you to use the same type of approach as before:

```
$ ls | wc -l
```

```
10
```

```
$
```

The output indicates that the current directory contains 10 files.

It is also possible to form a pipeline consisting of more than two programs, with the output of one program feeding into the input of the next.

## Filters

The term *filter* is often used in Unix terminology to refer to any program that can take input from standard input, perform some operation on that input, and write the results to standard output. More succinctly, a filter is any program that can be used between two other programs in a pipeline. So in the previous pipeline, `wc` is considered a filter. `ls` is not because it does not read its input from standard input. As other examples, `cat` and `sort` are filters, whereas `who`, `date`, `cd`, `pwd`, `echo`, `rm`, `mv`, and `cp` are not.

Team LiB

◀ PREVIOUS

NEXT ▶



## Standard Error

In addition to standard input and standard output, there is another place known as *standard error*. This is where most Unix commands write their error messages. And as with the other two "standard" places, standard error is associated with your terminal by default. In most cases, you never know the difference between standard output and standard error:

```
$ ls n*           List all files beginning with n
n* not found
$
```

Here the "not found" message is actually being written to standard error and not standard output by the `ls` command. You can verify that this message is not being written to standard output by redirecting the `ls` command's output:

```
$ ls n* > foo
n* not found
$
```

So, you still get the message printed out at the terminal, even though you redirected standard output to the file `foo`.

The preceding example shows the *raison d'être* for standard error: so that error messages will still get displayed at the terminal even if standard output is redirected to a file or piped to another command.

You can also redirect standard error to a file by using the notation

```
command 2> file
```

No space is permitted between the `2` and the `>`. Any error messages normally intended for standard error will be diverted into the specified *file*, similar to the way standard output gets redirected.

```
$ ls n* 2> errors
```

```
$ cat errors
```

```
n* not found
```

```
$
```

**Team LiB**

[◀ PREVIOUS](#)

[NEXT ▶](#)

## More on Commands

### Typing More Than One Command on a Line

You can type more than one command on a line provided that you separate each command with a semicolon. For example, you can find out the current time and also your current working directory by typing in the `date` and `pwd` commands on the same line:

```
$ date; pwd
```

```
Sat Jul 20 14:43:25 EDT 2002
```

```
/users/pat/bin
```

```
$
```

You can string out as many commands as you want on the line, as long as each command is delimited by a semicolon.

### Sending a Command to the Background

Normally, you type in a command and then wait for the results of the command to be displayed at the terminal. For all the examples you have seen thus far, this waiting time is typically short—maybe a second or two. However, you may have to run commands that require many seconds or even minutes to execute. In those cases, you'll have to wait for the command to finish executing before you can proceed further *unless you execute the command in the background*.

If you type in a command followed by the ampersand character `&`, that command will be sent to the background for execution. This means that the command will no longer tie up your terminal, and you can then proceed with other work. The standard output from the command will still be directed to your terminal; however, in most cases the standard input will be dissociated from your terminal. If the command does try to read any input from standard input, it will be stopped and will wait for you to bring it to the foreground (we'll discuss this in more detail in Chapter 15, "Interactive and Nonstandard Shell Features").<sup>[3]</sup>

<sup>[3]</sup> Note that the capability to stop a command when it reads from standard input may be missing on non-Unix implementations of the shell or on older shells that do not conform to the POSIX standard. On these implementations, any read from standard input will get an end-of-file condition as if `Ctrl+d` were typed.

```
$ sort data > out &    Send the sort to the background
```

```
[1] 1258          Process id

$ date           Your terminal is immediately available to do other work

Sat Jul 20 14:45:09 EDT 2002

$
```

When a command is sent to the background, the Unix system automatically displays two numbers. The first is called the command's *job number* and the second the *process id*. In the preceding example, 1 was the job number and 1258 the process id. The job number is used by some shell commands that you'll learn more about in Chapter 15 . The process id uniquely identifies the command that you sent to the background and can be used to obtain status information about the command. This is done with the `ps` command.

## The `ps` Command

The `ps` command gives you information about the processes running on the system. `ps` without any options prints the status of just your processes. If you type in `ps` at your terminal, you'll get a few lines back describing the processes you have running:

```
$ ps

  PID  TTY  TIME COMMAND
  195   01  0:21 sh      The shell
 1353   01  0:00 ps      This ps command
 1258   01  0:10 sort    The previous sort

$
```

The `ps` command prints out four columns of information: `PID` , the process id; `TTY` , the terminal number that the process was run from; `TIME` , the amount of computer time in minutes and seconds that process has used; and `COMMAND` , the name of the process. (The `sh` process in the preceding example is the shell that was started when you logged in, and it has used 21 seconds of computer time.) Until the command is finished, it shows up in the output of the `ps` command as a running process. Process number 1353 in the preceding example is the `ps` command that was typed in, and 1258 is the `sort` from the preceding example.

When used with the `-f` option, `ps` prints out more information about your processes, including the *parent* process id (`PPID` ), the time the processes started (`STIME` ), and the command arguments:

```
$ ps -f
```

UID	PID	PPID	C	STIME	TTY	TIME	COMMAND
steve	195	1	0	10:58:29	tty01	0:21	-sh
steve	1360	195	43	14:54:48	tty01	0:01	ps -f
steve	1258	195	0	14:45:04	tty01	3:17	sort data

```
$
```

**Team LiB**

◀ PREVIOUS

NEXT ▶

## Command Summary

[Table 2.2](#) summarizes the commands reviewed in this chapter. In this table, *file* refers to a file, *file(s)* to one or more files, *dir* to a directory, and *dir(s)* to one or more directories.

Table 2.2. Command Summary

Command	Description
<code>cat file(s)</code>	Display contents of <i>file(s)</i> or standard input if not supplied
<code>cd dir</code>	Change working directory to <i>dir</i>
<code>cp file<sub>1</sub> file<sub>2</sub></code>	Copy <i>file<sub>1</sub></i> to <i>file<sub>2</sub></i>
<code>cp file(s) dir</code>	Copy <i>file(s)</i> into <i>dir</i>
<code>date</code>	Display the date and time
<code>echo args</code>	Display <i>args</i>
<code>ln file<sub>1</sub> file<sub>2</sub></code>	Link <i>file<sub>1</sub></i> to <i>file<sub>2</sub></i>
<code>ln file(s) dir</code>	Link <i>file(s)</i> into <i>dir</i>
<code>ls file(s)</code>	List <i>file(s)</i>
<code>ls dir(s)</code>	List files in <i>dir(s)</i> or in current directory if <i>dir(s)</i> is not specified
<code>mkdir dir(s)</code>	Create directory <i>dir(s)</i>
<code>mv file<sub>1</sub> file<sub>2</sub></code>	Move <i>file<sub>1</sub></i> to <i>file<sub>2</sub></i> (simply rename it if both reference the same directory)
<code>mv file(s) dir</code>	Move <i>file(s)</i> into directory <i>dir</i>
<code>ps</code>	List information about active processes
<code>pwd</code>	Display current working directory path
<code>rm file(s)</code>	Remove <i>files(s)</i>
<code>rmdir dir(s)</code>	Remove empty directory <i>dir(s)</i>
<code>sort file(s)</code>	Sort lines of <i>file(s)</i> or standard input if not supplied
<code>wc file(s)</code>	Count the number of lines, words, and characters in <i>file(s)</i> or standard input if not supplied

Command

`who`

Description

Display who's logged in

**Team LiB**

◀ PREVIOUS

NEXT ▶

# Exercises

1: Given the following files in your current directory:

```
$ ls  
  
feb96  
  
jan12.02  
  
jan19.02  
  
jan26.02  
  
jan5.02  
  
jan95  
  
jan96  
  
jan97  
  
jan98  
  
mar98  
  
memo1  
  
memo10  
  
memo2  
  
memo2.sv  
  
$
```

What would be the output from the following commands?

```
echo *  
echo m[a-df-z]*  
echo *[^0-9]  
echo [A-Z]*
```



```
echo jan*           echo *.*
echo ?????         echo *02
echo jan?? feb??  mar??   echo [fjm][ae][bnr]*
```

2: What is the effect of the following command sequences?

```
ls | wc -l         rm ???
who | wc -l        mv progs/* /users/steve/backup
ls *.c | wc -l    rm *.o
who | sort         cd; pwd
cp mem01 ..       plotdata 2>errors &
```

# Chapter 3. What Is the Shell?

## IN THIS CHAPTER

- [The Kernel and the Utilities](#)
- [The Login Shell](#)
- [Typing Commands to the Shell](#)
- [The Shell's Responsibilities](#)

In this chapter you'll learn what the shell is and what it does.

## The Kernel and the Utilities

The Unix system is itself logically divided into two pieces: the *kernel* and the *utilities* (see [Figure 3.1](#)).

Figure 3.1. The Unix system.

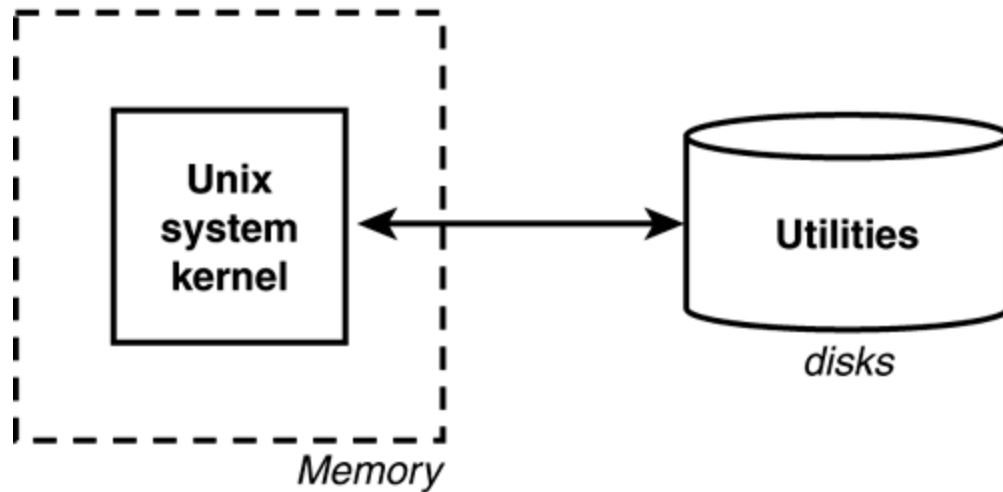

The kernel is the heart of the Unix system and resides in the computer's memory from the time the computer is turned on and *booted* until the time it is shut down.

The utilities, on the other hand, reside on the computer's disk and are only brought into memory as requested. Virtually every command you know under the Unix system is classified as a utility; therefore, the program resides on the disk and is brought into memory only when you request that the command be executed. So, for example, when you execute the `date` command, the Unix system loads the program called `date` from the computer's disk into memory and initiates its execution.

The shell, too, is a utility program. It is loaded into memory for execution whenever you log in to the system.

In fact, it's worth learning the precise sequence of events that occurs when the first shell on a terminal or window starts up.

## The Login Shell

A terminal is connected to a Unix system through a direct wire, modem, or network. In the first case, as soon as you turn on the terminal (and press the Enter key a couple of times if necessary), you should get a `login:` message on your screen. In the second case, you must first dial the computer's number and get connected before the `login:` message appears. In the last case, you may connect over the network via a program such as `ssh`, `telnet`, or `rlogin`, or you may use some kind of networked windowing system (for example, X Window System) to start up a terminal emulation program (for example, `xterm`).

For each physical terminal port on a system, a program called `getty` will be active. This is depicted in [Figure 3.2](#).

Figure 3.2. The `getty` process.

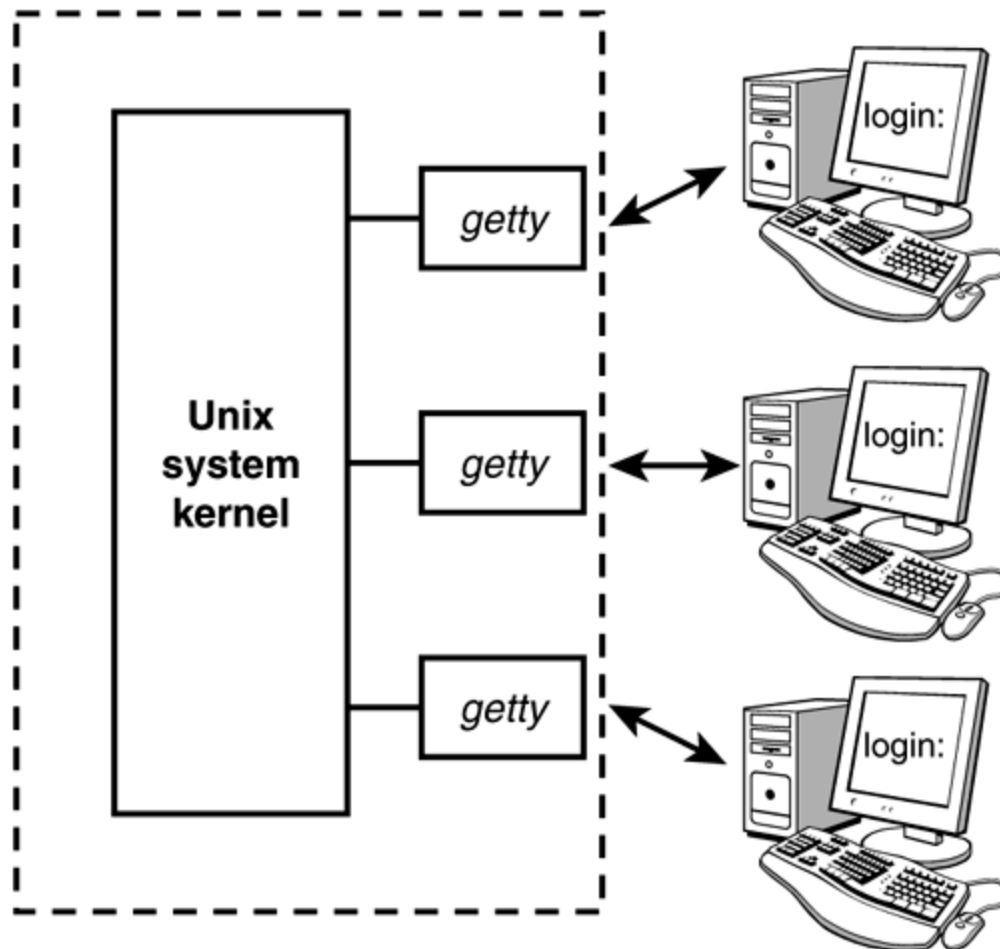

The Unix system—more precisely a program called `init`—automatically starts up a `getty` program on each terminal port whenever the system is allowing users to log in. `getty` determines the baud rate,

displays the message `login:` at its assigned terminal, and then just waits for someone to type in something. As soon as someone types in some characters followed by Enter, the `getty` program disappears; but before it goes away, it starts up a program called `login` to finish the process of logging in (see [Figure 3.3](#)). It also gives `login` the characters you typed in at the terminal—characters that presumably represent your login name.

Figure 3.3. `login` started on `sue`'s terminal.

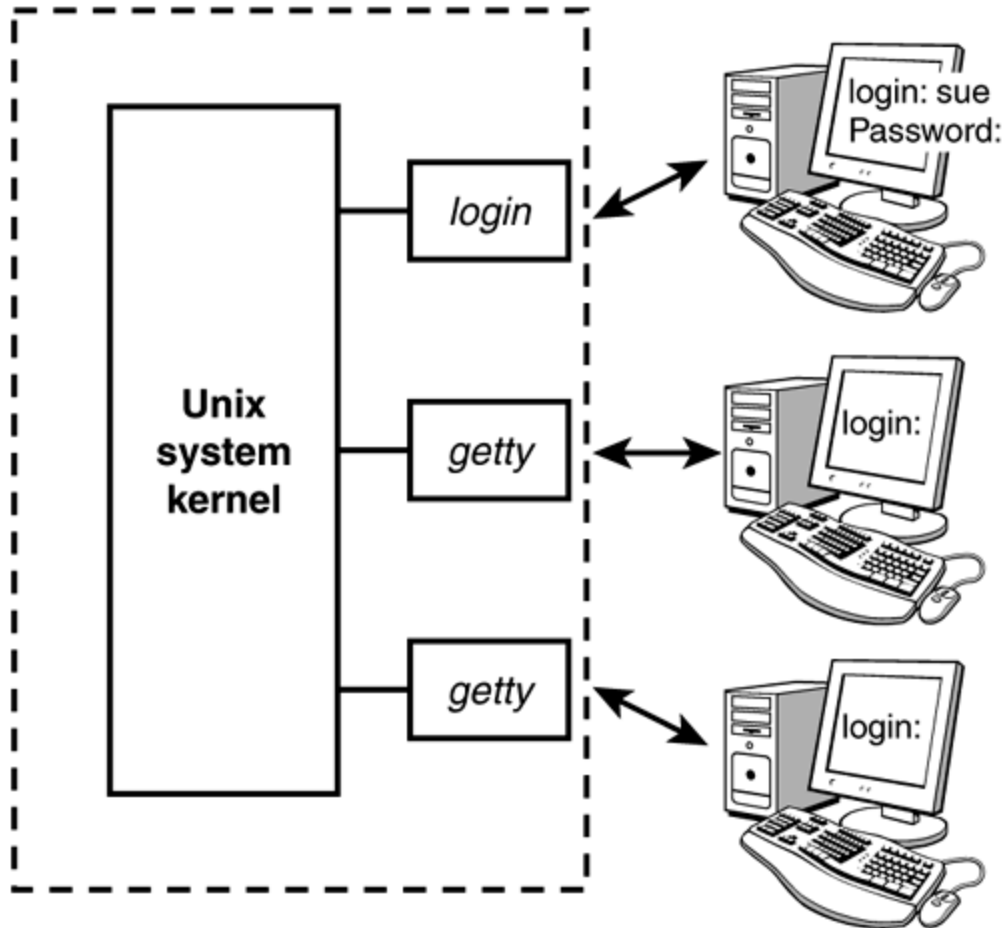

When `login` begins execution, it displays the string `Password:` at the terminal and then waits for you to type your password. After you have typed it, `login` then proceeds to verify your login name and password against the corresponding entry in the file `/etc/passwd`. This file contains one line for each user of the system. That line specifies, among other things, the login name, home directory, and program to start up when that user logs in.<sup>[1]</sup> The last bit of information (the program to start up) is stored after the *last* colon of each line. If nothing follows the last colon, the *standard* shell `/usr/bin/sh` is assumed by default. The following three lines show typical lines from `/etc/passwd` for three users of the system: `sue`, `pat`, and `bob`:

<sup>[1]</sup> The file's name (`passwd`) derives from a time when encrypted versions of the users' passwords were stored in this file along with other user information. The encrypted passwords are no longer stored in `/etc/passwd` but for security reasons are now kept in the `/etc/shadow` file, which is not readable by normal users.

```
sue:*:15:47::/users/sue:
```

```
pat:*:99:7::/users/pat:/usr/bin/ksh
```

```
bob:*:13:100::/users/data:/users/data/bin/data_entry
```

After `login` checks the password you typed in against the one stored in `/etc/shadow`, it then checks for the name of a program to execute. In most cases, this will be `/usr/bin/sh`, `/usr/bin/ksh`, or `/bin/bash`. In other cases, it may be a special custom-designed program. The main point here is that you can set up a login account to automatically run any program whatsoever whenever someone logs in to it. The shell just happens to be the program most often selected.

So `login` initiates execution of the standard shell on `sue`'s terminal after validating her password (see [Figure 3.4](#)).

Figure 3.4. `login` executes `/usr/bin/sh`.

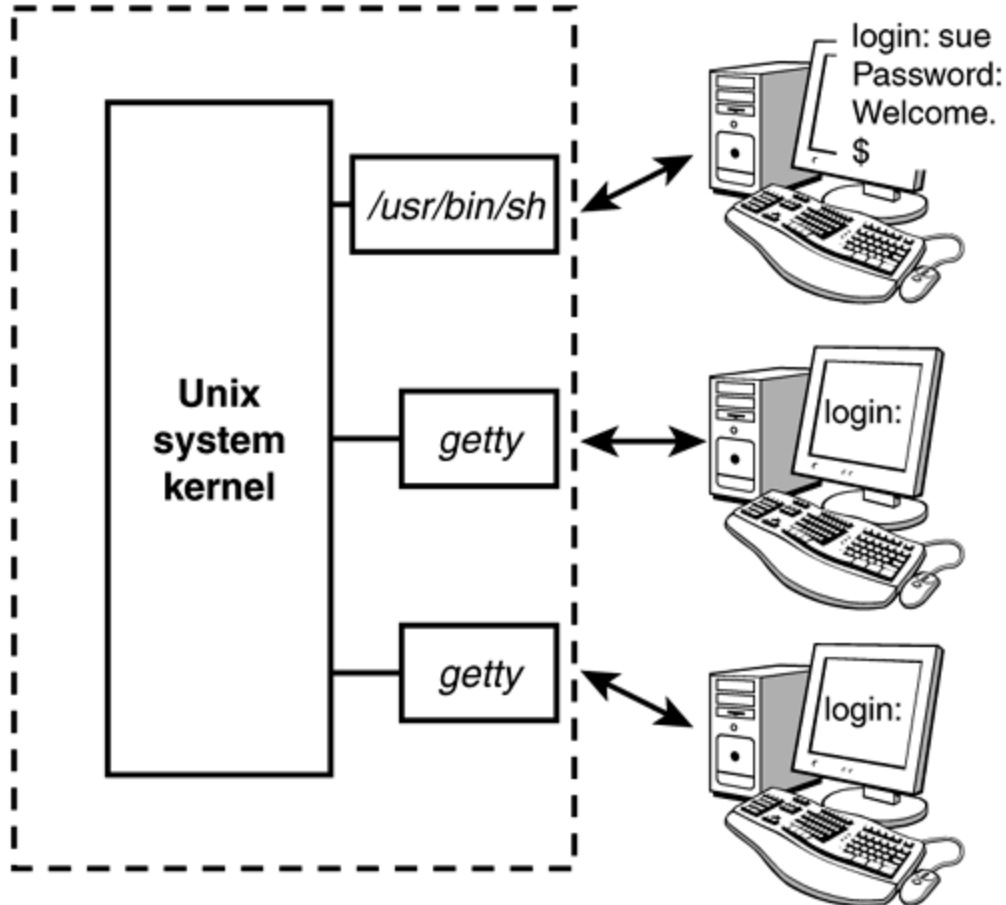

According to the other entries from `/etc/passwd` shown previously, `pat` gets the program `ksh` stored in `/usr/bin` (this is the Korn shell), and `bob` gets the program `data_entry` (see [Figure 3.5](#)).

Figure 3.5. Three users logged in.

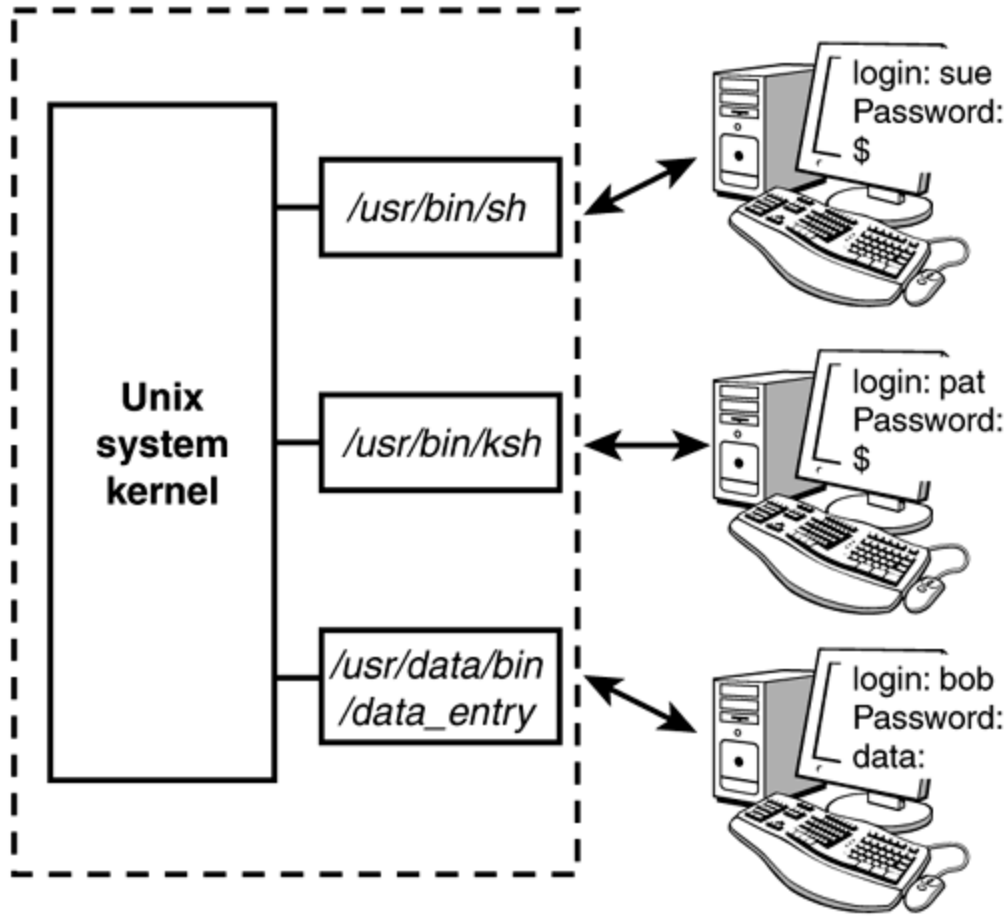

The `init` program starts up other programs similar to `getty` for networked connections. For example, `sshd`, `telnetd`, and `rlogind` are started to service logins via `ssh`, `telnet`, and `rlogin`, respectively. Instead of being tied directly to a specific, physical terminal or modem line, these programs connect users' shells to *pseudo ttys*. These are devices that emulate terminals over network connections. You can see this whether you're logged in to your system over a network or on an X Windows screen:

```
$ who  
  
phw      pts/0      Jul 20 17:37      Logged in with rlogin  
  
$
```

## Typing Commands to the Shell

When the shell starts up, it displays a command prompt—typically a dollar sign `$`—at your terminal and then waits for you to type in a command (see [Figure 3.6](#), Steps 1 and 2). Each time you type in a command and press the Enter key (Step 3), the shell analyzes the line you typed and then proceeds to carry out your request (Step 4). If you ask it to execute a particular program, the shell searches the disk until it finds the named program. When found, the shell asks the kernel to initiate the program's execution and then the shell "goes to sleep" until the program has finished (Step 5). The kernel copies the specified program into memory and begins its execution. This copied program is called a *process*; in this way, the distinction is made between a program that is kept in a file on the disk and a process that is in memory doing things.

Figure 3.6. Command cycle.

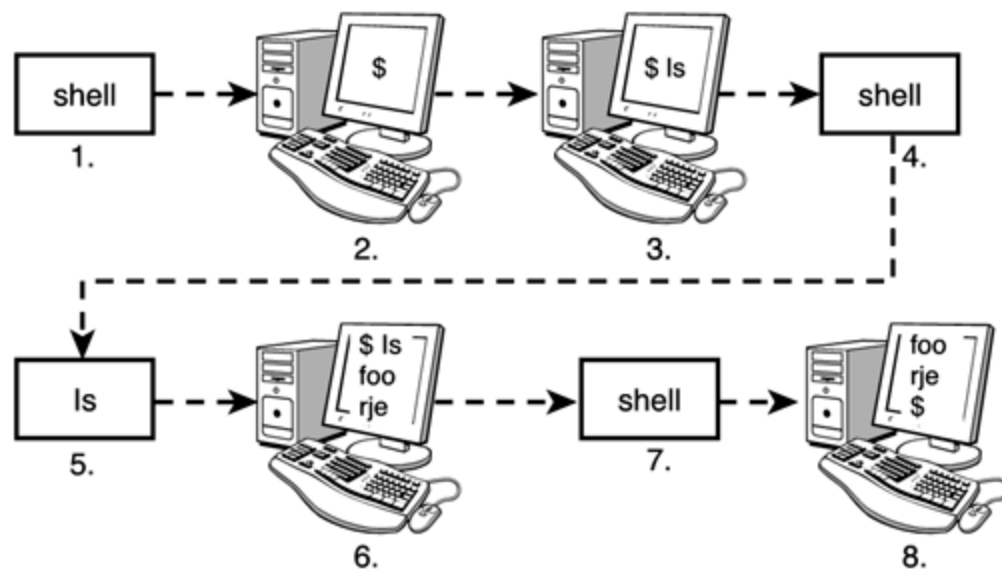

If the program writes output to standard output, it will appear at your terminal unless redirected or piped into another command. Similarly, if the program reads input from standard input, it will wait for you to type in input unless redirected from a file or piped from another command (Step 6).

When the command finishes execution, control once again returns to the shell, which awaits your next command (Steps 7 and 8).

Note that this cycle continues as long as you're logged in. When you log off the system, execution of the shell then terminates and the Unix system starts up a new `getty` (or `rlogind`, and so on) at the terminal and waits for someone else to log in. This cycle is illustrated in [Figure 3.7](#).

Figure 3.7. Login cycle.



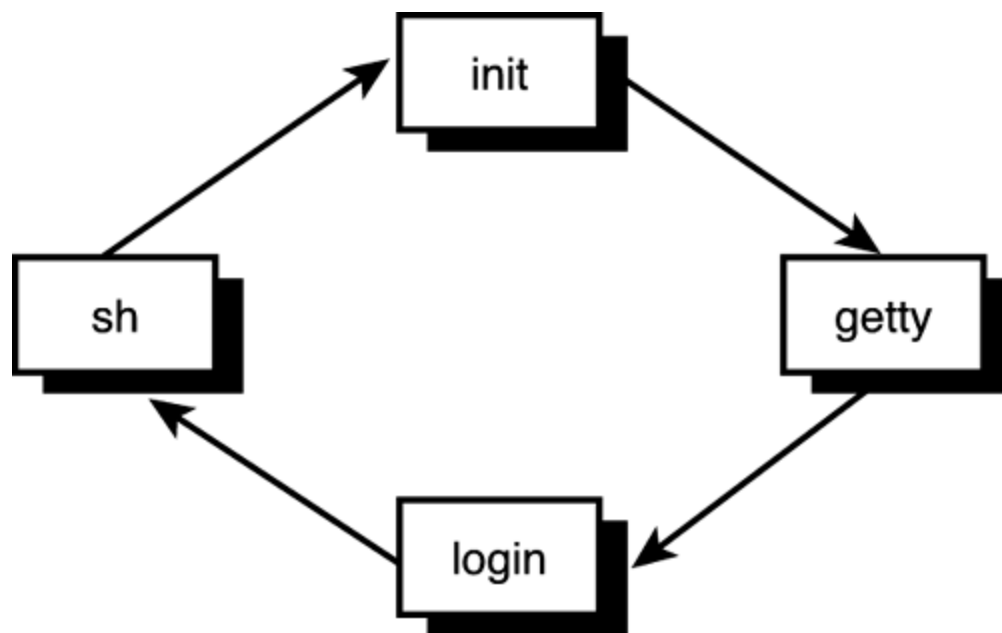

It's important for you to recognize that the shell is just a program. It has no special privileges on the system, meaning that anyone with the capability and devotion can create his own shell program. This is in fact the reason why various flavors of the shell exist today, including the older Bourne shell, developed by Stephen Bourne; the Korn shell, developed by David Korn; the "Bourne again shell," mainly used on Linux systems; and the C shell, developed by Bill Joy.

## The Shell's Responsibilities

Now you know that the shell analyzes each line you type in and initiates execution of the selected program. But the shell also has other responsibilities, as outlined in [Figure 3.8](#).

Figure 3.8. The shell's responsibilities.

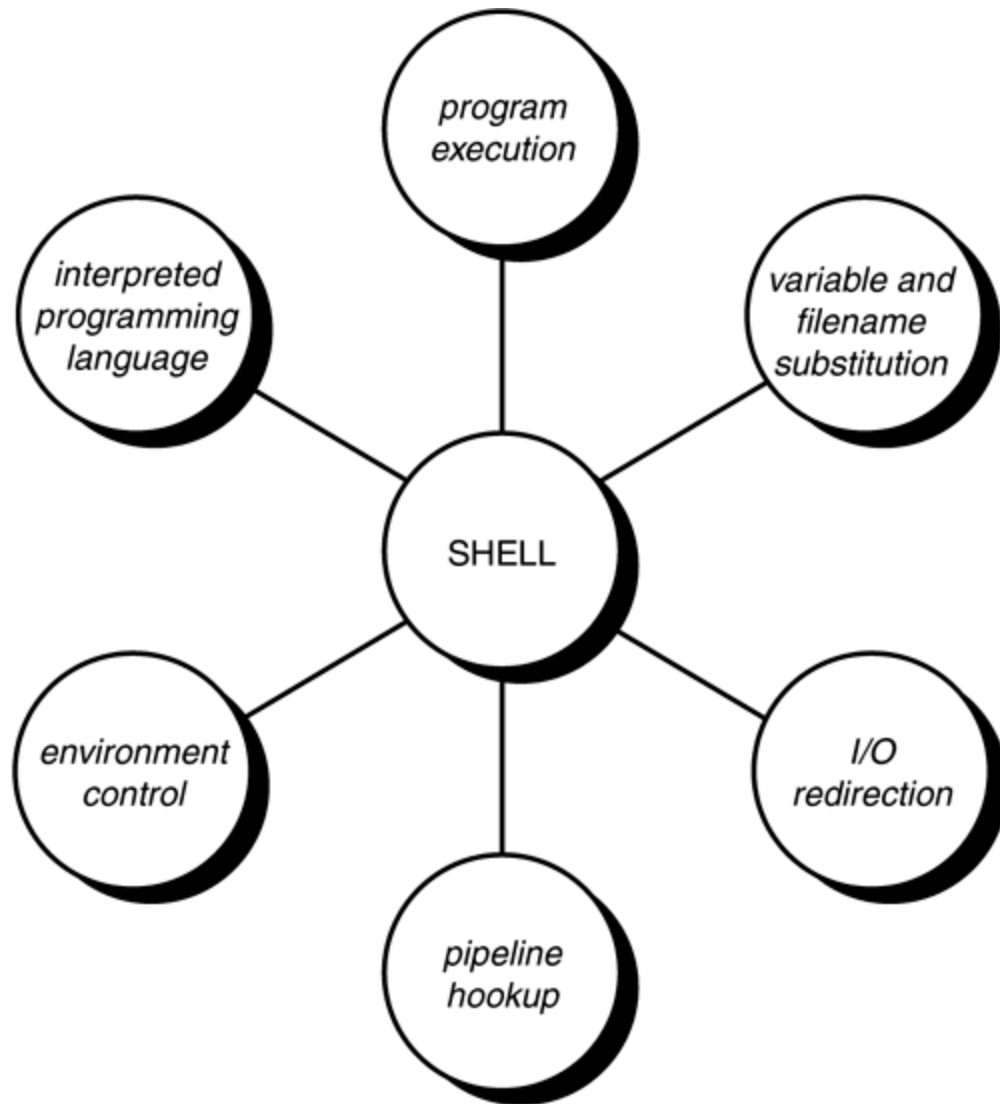

### Program Execution

The shell is responsible for the execution of all programs that you request from your terminal.

Each time you type in a line to the shell, the shell analyzes the line and then determines what to do. As far as the shell is concerned, each line follows the same basic format:

*program-name arguments*

The line that is typed to the shell is known more formally as the *command line*. The shell scans this command line and determines the name of the program to be executed and what arguments to pass to the program.

The shell uses special characters to determine where the program name starts and ends, and where each argument starts and ends. These characters are collectively called *whitespace characters*, and are the space character, the horizontal tab character, and the end-of-line character, known more formally as the *newline character*. Multiple occurrences of whitespace characters are simply ignored by the shell. When you type the command

```
mv tmp/mazewars games
```

the shell scans the command line and takes everything from the start of the line to the first whitespace character as the name of the program to execute: `mv`. The set of characters up to the next whitespace character is the first argument to `mv`: `tmp/mazewars`. The set of characters up to the next whitespace character (known as a word to the shell)—in this case, the newline—is the second argument to `mv`: `games`. After analyzing the command line, the shell then proceeds to execute the `mv` command, giving it the two arguments `tmp/mazewars` and `games` (see [Figure 3.9](#)).

Figure 3.9. Execution of `mv` with two arguments.

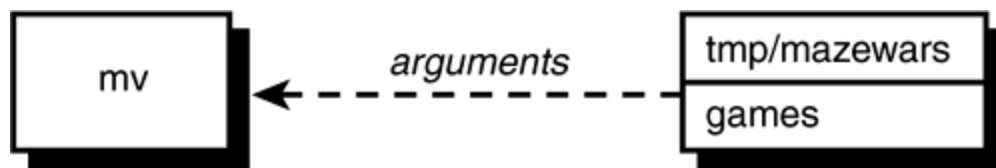

As mentioned, multiple occurrences of whitespace characters are ignored by the shell. This means that when the shell processes this command line:

```
echo          when  do          we    eat?
```

it passes four arguments to the `echo` program: `when`, `do`, `we`, and `eat?` (see [Figure 3.10](#)).

Figure 3.10. Execution of `echo` with four arguments.

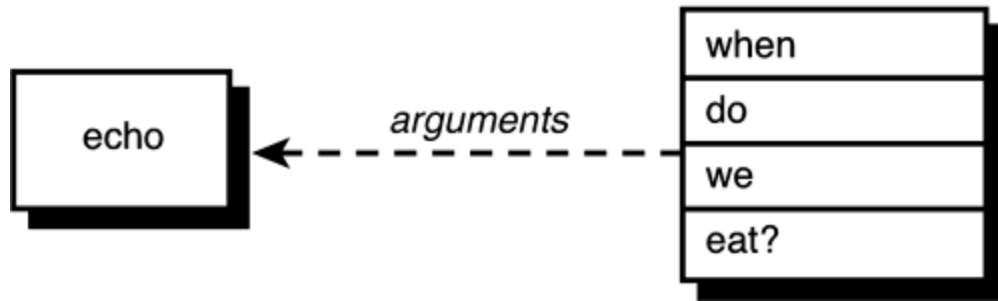

Because `echo` takes its arguments and simply displays them at the terminal, separating each by a space character, the output from the following becomes easy to understand:

```
$ echo      when      do      we      eat?
when do we eat?
$
```

The fact is that the `echo` command never sees those blank spaces; they have been "gobbled up" by the shell. When we discuss quotes in [Chapter 6](#), "Can I Quote You on That?," you'll see how you can include blank spaces in arguments to programs.

We mentioned earlier that the shell searches the disk until it finds the program you want to execute and then asks the Unix kernel to initiate its execution. This is true most of the time. However, there are some commands that the shell knows how to execute itself. These built-in commands include `cd`, `pwd`, and `echo`. So before the shell goes searching the disk for a command, the shell first determines whether it's a built-in command, and if it is, the shell executes the command directly.

## Variable and Filename Substitution

Like any other programming language, the shell lets you assign values to variables. Whenever you specify one of these variables on the command line, preceded by a dollar sign, the shell substitutes the value assigned to the variable at that point. This topic is covered in complete detail in [Chapter 5](#), "And Away We Go."

The shell also performs filename substitution on the command line. In fact, the shell scans the command line looking for filename substitution characters `*`, `?`, or `[...]` before determining the name of the program to execute and its arguments. Suppose that your current directory contains the files as shown:

```
$ ls
mrs.todd
```

```
progl
shortcut
sweeney
$
```

Now let's use filename substitution for the `echo` command:

```
$ echo *           List all files
mrs.todd progl shortcut sweeney
$
```

How many arguments do you think were passed to the `echo` program, one or four? Because we said that the shell is the one that performs the filename substitution, the answer is four. When the shell analyzes the line

```
echo *
```

it recognizes the special character `*` and substitutes on the command line the names of all files in the current directory (it even alphabetizes them for you):

```
echo mrs.todd progl shortcut sweeney
```

Then the shell determines the arguments to be passed to the command. So `echo` never sees the asterisk. As far as it's concerned, four arguments were typed on the command line (see [Figure 3.11](#)).

Figure 3.11. Execution of `echo`.

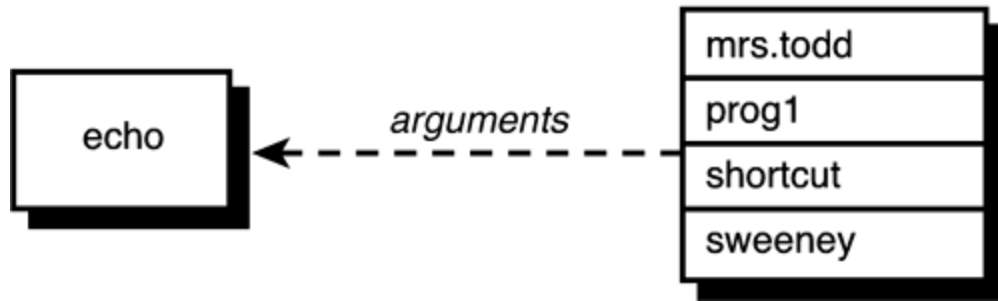

## I/O Redirection

It is the shell's responsibility to take care of input and output redirection on the command line. It scans the command line for the occurrence of the special redirection characters `<`, `>`, or `>>` (also `<<` as you'll learn in [Chapter 13](#), "Loose Ends").

When you type the command

```
echo Remember to tape Law and Order > reminder
```

the shell recognizes the special output redirection character `>` and takes the next word on the command line as the name of the file that the output is to be redirected to. In this case, the file is `reminder`. If `reminder` already exists and you have write access to it, the previous contents are lost (if you don't have write access to it, the shell gives you an error message).

Before the shell starts execution of the desired program, it redirects the standard output of the program to the indicated file. As far as the program is concerned, it never knows that its output is being redirected. It just goes about its merry way writing to standard output (which is normally your terminal, you'll recall), unaware that the shell has redirected it to a file.

Let's take another look at two nearly identical commands:

```
$ wc -l users
  5 users
$ wc -l < users
  5
$
```

In the first case, the shell analyzes the command line and determines that the name of the program

to execute is `wc` and it is to be passed two arguments: `-l` and `users` (see [Figure 3.12](#)).

Figure 3.12. Execution of `wc -l users`.

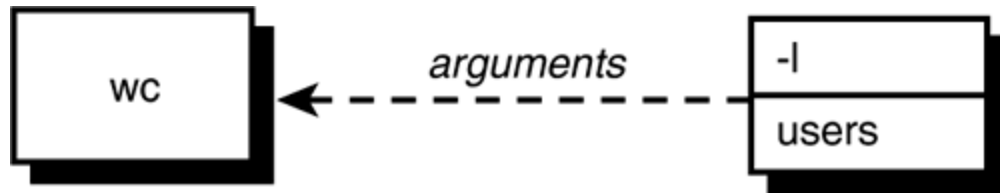

When `wc` begins execution, it sees that it was passed two arguments. The first argument, `-l`, tells it to count the number of lines. The second argument specifies the name of the file whose lines are to be counted. So `wc` opens the file `users`, counts its lines, and then prints the count together with the filename at the terminal.

Operation of `wc` in the second case is slightly different. The shell spots the input redirection character `<` when it scans the command line. The word that follows on the command line is the name of the file input is to be redirected from. Having "gobbled up" the `< users` from the command line, the shell then starts execution of the `wc` program, redirecting its standard input from the file `users` and passing it the single argument `-l` (see [Figure 3.13](#)).

Figure 3.13. Execution of `wc -l < users`.

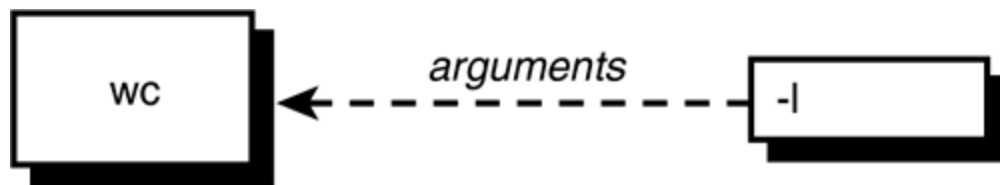

When `wc` begins execution this time, it sees that it was passed the single argument `-l`. Because no filename was specified, `wc` takes this as an indication that the number of lines appearing on standard input is to be counted. So `wc` counts the number of lines on standard input, unaware that it's actually counting the number of lines in the file `users`. The final tally is displayed at the terminal—without the name of a file because `wc` wasn't given one.

The difference in execution of the two commands is important for you to understand. If you're still unclear on this point, review the preceding section.

## Pipeline Hookup

Just as the shell scans the command line looking for redirection characters, it also looks for the pipe character `|`. For each such character that it finds, it connects the standard output from the command preceding the `|` to the standard input of the one following the `|`. It then initiates execution of both programs.

So when you type

```
who | wc -l
```

the shell finds the pipe symbol separating the commands `who` and `wc`. It connects the standard output of the former command to the standard input of the latter, and then initiates execution of both commands. When the `who` command executes, it makes a list of who's logged in and writes the results to standard output, unaware that this is not going to the terminal but to another command instead.

When the `wc` command executes, it recognizes that no filename was specified and counts the lines on standard input, unaware that standard input is not coming from the terminal but from the output of the `who` command.

## Environment Control

The shell provides certain commands that let you customize your environment. Your environment includes your home directory, the characters that the shell displays to prompt you to type in a command, and a list of the directories to be searched whenever you request that a program be executed. You'll learn more about this in [Chapter 11](#), "Your Environment."

## Interpreted Programming Language

The shell has its own built-in programming language. This language is *interpreted*, meaning that the shell analyzes each statement in the language one line at a time and then executes it. This differs from programming languages such as C and FORTRAN, in which the programming statements are typically compiled into a machine-executable form before they are executed.

Programs developed in interpreted programming languages are typically easier to debug and modify than compiled ones. However, they usually take much longer to execute than their compiled equivalents.

The shell programming language provides features you'd find in most other programming languages. It has looping constructs, decision-making statements, variables, and functions, and is procedure-oriented. Modern shells based on the IEEE POSIX standard have many other features including arrays, data typing, and built-in arithmetic operations.



# Chapter 4. Tools of the Trade

## IN THIS CHAPTER

- [Regular Expressions](#)
- [cut](#)
- [paste](#)
- [sed](#)
- [tr](#)
- [grep](#)
- [sort](#)
- [uniq](#)
- [Exercises](#)

This chapter provides detailed descriptions of some commonly used shell programming tools. Covered are `cut`, `paste`, `sed`, `tr`, `grep`, `uniq`, and `sort`. The more proficient you become at using these tools, the easier it will be to write shell programs to solve your problems. In fact, that goes for all the tools provided by the Unix system.

# Regular Expressions

Before getting into the tools, you need to learn about *regular expressions*. Regular expressions are used by several different Unix commands, including `ed`, `sed`, `awk`, `grep`, and, to a more limited extent, `vi`. They provide a convenient and consistent way of specifying *patterns* to be matched.

The shell recognizes a limited form of regular expressions when you use filename substitution. Recall that the asterisk (\*) specifies zero or more characters to match, the question mark (?) specifies any single character, and the construct [...] specifies any character enclosed between the brackets. The regular expressions recognized by the aforementioned programs are far more sophisticated than those recognized by the shell. Also be advised that the asterisk and the question mark are treated differently by these programs than by the shell.

Throughout this section, we assume familiarity with a line-based editor such as `ex` or `ed`. See [Appendix B](#), "For More Information," for more information on these editors.

## Matching Any Character: The Period (.)

A period in a regular expression matches any single character, no matter what it is. So the regular expression

```
r.
```

specifies a pattern that matches an `r` followed by any single character.

The regular expression

```
.x.
```

matches an `x` that is surrounded by any two characters, not necessarily the same.

The `ed` command

```
/ ... /
```

searches forward in the file you are editing for the first line that contains any three characters surrounded by blanks:

```
$ ed intro
```

```
248
```

```
1,$p          Print all the lines
```

```
The Unix operating system was pioneered by Ken  
Thompson and Dennis Ritchie at Bell Laboratories  
in the late 1960s. One of the primary goals in  
the design of the Unix system was to create an  
environment that promoted efficient program  
development.
```

```
/ ... / Look for three chars surrounded by blanks
```

```
The Unix operating system was pioneered by Ken
```

```
/ Repeat last search
```

```
Thompson and Dennis Ritchie at Bell Laboratories
```

```
1,$s/p.o/XXX/g      Change all p.os to XXX
```

```
1,$p          Let's see what happened
```

```
The Unix operating system was XXXneered by Ken  
ThomXXXn and Dennis Ritchie at Bell Laboratories  
in the late 1960s. One of the primary goals in  
the design of the Unix system was to create an  
environment that XXXmoted efficient XXXgram  
development.
```

In the first search, `ed` started searching from the beginning of the file and found the characters " was " in the first line that matched the indicated pattern. Repeating the search (recall that the `ed` command `/` means to repeat the last search), resulted in the display of the second line of the file

because " and " matched the pattern. The substitute command that followed specified that all occurrences of the character p, followed by any single character, followed by the character o were to be replaced by the characters xxx.

## Matching the Beginning of the Line: The Caret (^)

When the caret character ^ is used as the first character in a regular expression, it matches the beginning of the line. So the regular expression

```
^George
```

matches the characters *George* *only if they occur at the beginning of the line.*

```
$ ed intro
```

```
248
```

```
/^the/           Find the line that starts with the
```

```
the design of the Unix system was to create an
```

```
1,$s/^/>>/      Insert >> at the beginning of each line
```

```
1,$p
```

```
>>The Unix operating system was pioneered by Ken
```

```
>>Thompson and Dennis Ritchie at Bell Laboratories
```

```
>>in the late 1960s. One of the primary goals in
```

```
>>the design of the Unix system was to create an
```

```
>>environment that promoted efficient program
```

```
>>development.
```

The preceding example shows how the regular expression ^ can be used to match just the beginning of the line. Here it is used to insert the characters >> at the start of each line. A command such as

```
1,$s/^/ /
```

is commonly used to insert spaces at the start of each line (in this case five spaces would be inserted).

## Matching the End of the Line: The Dollar Sign (\$)

Just as the `^` is used to match the beginning of the line, so is the dollar sign `$` used to match the end of the line. So the regular expression

```
contents$
```

matches the characters `contents` *only if they are the last characters on the line*. What do you think would be matched by the regular expression `.$`?

Would this match a period character that ends a line? No. This matches any single character at the end of the line (including a period) recalling that the period matches any character. So how do you match a period? In general, if you want to match any of the characters that have a special meaning in forming regular expressions, you must precede the character by a backslash (`\`) to remove that special meaning. So the regular expression

```
\.$
```

matches any line that ends in a period, and the regular expression

```
^\.
```

matches any line that starts with one (good for searching for `nroff` commands in your text).

```
$ ed intro
```

```
248
```

```
/\.$/
```

*Search for a line that ends with a period*

```
development.
```

**1,\$s/\$/>>>/**      *Add >> to the end of each line*

**1,\$p**

The Unix operating system was pioneered by Ken>>  
Thompson and Dennis Ritchie at Bell Laboratories>>  
in the late 1960s. One of the primary goals in>>  
the design of the Unix system was to create an>>  
environment that promoted efficient program>>  
development.>>

**1,\$s/..\$//**      *Delete the last two characters from each line*

**1,\$p**

The Unix operating system was pioneered by Ken  
Thompson and Dennis Ritchie at Bell Laboratories  
in the late 1960s. One of the primary goals in  
the design of the Unix system was to create an  
environment that promoted efficient program  
development.

It's worth noting that the regular expression

**^\$**

matches any line that contains *no* characters (such a line can be created in **ed** by simply pressing Enter while in insert mode). This regular expression is to be distinguished from one such as

**^ \$**

which matches any line that consists of a single space character.

## Matching a Choice of Characters: The [...] Construct

Suppose that you are editing a file and want to search for the first occurrence of the characters `the`. In `ed`, this is easy: You simply type the command

```
/the/
```

This causes `ed` to search forward in its buffer until it finds a line containing the indicated string of characters. The first line that matches will be displayed by `ed`:

```
$ ed intro
```

```
248
```

```
/the/ Find line containing the  
in the late 1960s. One of the primary goals in
```

Notice that the first line of the file also contains the word `the`, except it starts a sentence and so begins with a capital T. You can tell `ed` to search for the first occurrence of `the` or `The` by using a regular expression. Just as in filename substitution, the characters `[` and `]` can be used in a regular expression to specify that one of the enclosed characters is to be matched. So, the regular expression

```
[tT]he
```

would match a lower- or uppercase `t` followed immediately by the characters `he`:

```
$ ed intro
```

```
248
```

```
/[tT]he/ Look for the or The  
The Unix operating system was pioneered by Ken
```

*Continue the search*  
in the late 1960s. One of the primary goals in

*Once again*  
the design of the Unix system was to create an

**1,\$s/[aeiouAEIOU]//g** *Delete all vowels*

**1,\$p**

The next printing system was produced by Ken  
Thompson and Dennis Ritchie at Bell Laboratories  
in the late 1960s. One of the primary goals in  
the design of the next system was to create a  
replacement that provided efficient program  
development.

A range of characters can be specified inside the brackets. This can be done by separating the starting and ending characters of the range by a dash (-). So, to match any digit character 0 through 9, you could use the regular expression

**[0123456789]**

or, more succinctly, you could simply write

**[0-9]**

To match an uppercase letter, you write

**[A-Z]**

And to match an upper- or lowercase letter, you write



[A-Za-z]

Here are some examples with `ed`:

```
$ ed intro
```

```
248
```

```
/[0-9]/          Find a line containing a digit
```

```
in the late 1960s. One of the primary goals in
```

```
 /^[A-Z]/        Find a line that starts with an uppercase letter
```

```
The Unix operating system was pioneered by Ken
```

```
 /              Again
```

```
Thompson and Dennis Ritchie at Bell Laboratories
```

```
1,$s/[A-Z]*/g    Change all uppercase letters to *s
```

```
1,$p
```

```
*he *nix operating system was pioneered by *en
```

```
*hompson and *ennis *itchie at *ell *aboratories
```

```
in the late 1960s. *ne of the primary goals in
```

```
the design of the *nix system was to create an
```

```
environment that promoted efficient program
```

```
development.
```

As you'll learn shortly, the asterisk is a special character in regular expressions. However, you don't need to put a backslash before the asterisk in the replacement string of the substitute command. In general, regular expression characters such as `*`, `.`, `[...]`, `$`, and `^` are only meaningful in the search string and have no special meaning when they appear in the replacement string.

If a caret (`^`) appears as the first character after the left bracket, the sense of the match is *inverted*.<sup>[1]</sup> For example, the regular expression

<sup>[1]</sup> Recall that the shell uses the `!` for this purpose.

```
[^A-Z]
```

matches any character *except* an uppercase letter. Similarly,

```
[^A-Za-z]
```

matches any nonalphabetic character.

```
$ ed intro
```

```
248
```

```
1,$s/[^a-zA-Z]//g      Delete all nonalphabetic characters
```

```
1,$p
```

```
TheUnixoperatingsystemwaspioneeredbyKen
```

```
ThompsonandDennisRitchieatBellLaboratories
```

```
InthelatesOneoftheprimarygoalsin
```

```
ThedesignoftheUnixsystemwastocreatean
```

```
Environmentthatpromotedefficientprogram
```

```
development
```

## Matching Zero or More Characters: The Asterisk (\*)

You know that the asterisk is used by the shell in filename substitution to match zero or more characters. In forming regular expressions, the asterisk is used to match zero or more occurrences of the *preceding* character in the regular expression (which may itself be another regular expression).

So, for example, the regular expression

X\*

matches zero, one, two, three, ... capital X's. The expression

XX\*

matches one or more capital X's, because the expression specifies a single X followed by zero or more X's. A similar type of pattern is frequently used to match the occurrence of one or more blank spaces.

```
$ ed lotsaspaces
```

```
85
```

```
1,$p
```

```
This      is  an example  of a  
file  that  contains      a lot
```

```
of  blank spaces
```

*Change multiple blanks to single blanks*

```
1,$s/ */ /g
```

```
1,$p
```

```
This is an example of a  
file that contains a lot  
of blank spaces
```

The `ed` command

```
1,$s/ */ /g
```

told `ed` to substitute all occurrences of a space followed by zero or more spaces with a single space.

The regular expression

`.*`

is often used to specify zero or more occurrences of *any* characters. Bear in mind that a regular expression matches the *longest* string of characters that match the pattern. Therefore, used by itself, this regular expression always matches the *entire* line of text.

As another example of the combination of `.` and `*`, the regular expression

`e.*e`

matches all the characters from the first `e` on a line to the last one.

```
$ ed intro
```

```
248
```

```
1,$s/e.*e/+/+/
```

```
1,$p
```

```
Th+++n
```

```
Thompson and D+++S
```

```
in th+++ primary goals in
```

```
th+++ an
```

```
+++nt program
```

```
d+++nt.
```

Here's an interesting regular expression. What do you think it matches?

```
[A-Za-z][A-Za-z]*
```

That's right, this matches any alphabetic character followed by zero or more alphabetic characters. This is pretty close to a regular expression that matches words.

```
$ ed intro
```

```
248
```

```
1,$s/[A-Za-z][A-Za-z]*/X/g
```

```
1,$p
```

```
X X X X X X X X
```

```
X X X X X X X
```

```
X X X 1960X. X X X X X X
```

```
X X X X X X X X X X
```

```
X X X X X
```

```
X.
```

The only thing it didn't match in this example was 1960. You can change the regular expression to also consider a sequence of digits as a word:

```
$ ed intro
```

```
248
```

```
1,$s/[A-Za-z0-9][A-Za-z0-9]*/X/g
```

```
1,$p
```

```
X X X X X X X X
```

```
X X X X X X X
```

```
X X X X. X X X X X X
```

```
X X X X X X X X X X
```

```
X X X X X
```

```
X.
```

We could expand on this somewhat to consider hyphenated words and contracted words (for example, don't), but we'll leave that as an exercise for you. As a point of note, if you want to match a dash character inside a bracketed choice of characters, you must put the dash immediately after the left bracket (and after the inversion character `^` if present) or immediately before the right bracket `]`. So the expression

```
[-0-9]
```

matches a single dash or digit character.

If you want to match a right bracket character, it must appear after the opening left bracket (and after the `^` if present). So

```
[ ]a-z]
```

matches a right bracket or a lowercase letter.

## Matching a Precise Number of Characters: `\{...\}`

In the preceding examples, you saw how to use the asterisk to specify that *one* or more occurrences of the preceding regular expression are to be matched. For instance, the regular expression

```
xx*
```

means match at least one consecutive `x`. Similarly,

```
xxx*
```

means match at least *two* consecutive `x`'s. There is a more general way to specify a precise number of characters to be matched: by using the construct

```
\{min,max\}
```

where *min* specifies the minimum number of occurrences of the preceding regular expression to be matched, and *max* specifies the maximum. For example, the regular expression

```
x\{1,10\}
```

matches from one to ten consecutive **x**'s. As stated before, whenever there is a choice, the largest pattern is matched; so if the input text contains eight consecutive **x**'s at the beginning of the line, that is how many will be matched by the preceding regular expression. As another example, the regular expression

```
[A-Za-z]\{4,7\}
```

matches a sequence of alphabetic letters from four to seven characters long.

```
$ ed intro
```

```
248
```

```
1,$s/[A-Za-z]\{4,7\}/X/q
```

```
1,$p
```

```
The X Xng X was Xed by Ken
```

```
Xn and X X at X XX
```

```
in the X 1960s. One of the X X in
```

```
the X of the X X was to X an
```

```
XX X Xd Xnt X
```

```
XX.
```

A few special cases of this special construct are worth noting. If only one number is enclosed between the braces, as in

`\{10\}`

that number specifies that the preceding regular expression must be matched *exactly* that many times. So

`[a-zA-Z]\{7\}`

matches exactly seven alphabetic characters; and

`.\{10\}`

matches exactly ten characters (no matter what they are):

```
$ ed intro
```

```
248
```

```
1,$s/^\{10\}//          Delete the first 10 chars from each line
```

```
1,$p
```

```
perating system was pioneered by Ken  
nd Dennis Ritchie at Bell Laboratories  
e 1960s. One of the primary goals in  
of the Unix system was to create an  
t that promoted efficient program  
t.
```

```
1,$s/.\{5\}$//          Delete the last 5 chars from each line
```

```
1,$p
```

```
perating system was pioneered b  
nd Dennis Ritchie at Bell Laborat
```



e 1960s. One of the primary goals  
of the Unix system was to create  
a system that promoted efficient programming.  
t.

Note that the last line of the file didn't have five characters when the last substitute command was executed; therefore, the match failed on that line and thus was left alone (recall that we specified that *exactly* five characters were to be deleted).

If a single number is enclosed in the braces, followed immediately by a comma, then at *least* that many occurrences of the previous regular expression must be matched. So

```
+\{5,\}
```

matches at least five consecutive plus signs. Once again, if more than five exist, the largest number is matched.

```
$ ed intro
```

```
248
```

```
1,$s/[a-zA-Z]\{6,\}/X/g Change words at least 6 letters long to X
```

```
1,$p
```

```
The Unix X X was X by Ken
```

```
X and X X at Bell X
```

```
in the late 1960s. One of the X goals in
```

```
the X of the Unix X was to X an
```

```
X that X X X
```

```
X.
```

**Saving Matched Characters: \(...\)**

It is possible to capture the characters matched within a regular expression by enclosing the characters inside backslashed parentheses. These captured characters are stored in "registers" numbered 1 through 9.

For example, the regular expression

```
^\(.\)
```

matches the first character on the line, whatever it is, and stores it into register 1. To retrieve the characters stored in a particular register, the construct `\n` is used, where `n` is from 1–9.

So the regular expression

```
^\(.\)\1
```

matches the first character on the line and stores it in register 1. Then the expression matches whatever is stored in register 1, as specified by the `\1`. The net effect of this regular expression is to match the first two characters on a line *if they are both the same character*. Go over this example if it doesn't seem clear.

The regular expression

```
^\(.\).*\1$
```

matches all lines in which the first character on the line (`^.`) is the same as the last character on the line (`\1$`). The `.*` matches all the characters in-between.

Successive occurrences of the `\(...\)` construct get assigned to successive registers. So when the following regular expression is used to match some text

```
^\(...\)\(...\)
```

the first three characters on the line will be stored into register 1, and the next three characters into register 2.

When using the substitute command in `ed`, a register can also be referenced as part of the replacement string:

```
$ ed phonebook
```

```
114
```

```
1,$p
```

```
Alice Chebba      973-555-2015
```

```
Barbara Swingle  201-555-9257
```

```
Liz Stachiw      212-555-2298
```

```
Susan Goldberg   201-555-7776
```

```
Tony Iannino     973-555-1295
```

```
1,$s/\(.*\)      \(.*\)/\2 \1/ Switch the two fields
```

```
1,$p
```

```
973-555-2015 Alice Chebba
```

```
201-555-9257 Barbara Swingle
```

```
212-555-2298 Liz Stachiw
```

```
201-555-7776 Susan Goldberg
```

```
973-555-1295 Tony Iannino
```

The names and the phone numbers are separated from each other in the `phonebook` file by a single tab character. The regular expression

```
\(.*\)      \(.*\)
```

says to match all the characters up to the first tab (that's the character between the `)` and the `\)` and assign them to register 1, and to match all the characters that follow the tab character and assign them to register 2. The replacement string

```
\2 \1
```

specifies the contents of register 2, followed by a space, followed by the contents of register 1.

So when `ed` applies the substitute command to the first line of the file:

```
Alice Chebba      973-555-2015
```

it matches everything up to the tab (`Alice Chebba`) and stores it into register 1, and everything after the tab (`973-555-2015`) and stores it into register 2. Then it substitutes the characters that were matched (the entire line) with the contents of register 2 (`973-555-2015`) followed by a space, followed by the contents of register 1 (`Alice Chebba`):

```
973-555-2015 Alice Chebba
```

As you can see, regular expressions are powerful tools that enable you to match complex patterns. [Table 4.1](#) summarizes the special characters recognized in regular expressions.

Table 4.1. Regular Expression Characters

Notation	Meaning	Example	Matches
<code>.</code>	<i>any</i> character	<code>a..</code>	<code>a</code> followed by any two characters
<code>^</code>	beginning of line	<code>^wood</code>	<code>wood</code> only if it appears at the beginning of the line
<code>\$</code>	end of line	<code>x\$</code>	<code>x</code> only if it is the last character on the line
		<code>^INSERT\$</code>	a line containing just the characters <code>INSERT</code>
		<code>^\$</code>	a line that contains <i>no</i> characters
<code>*</code>	zero or more occurrences of previous regular expression	<code>x*</code>	zero or more consecutive <code>x</code> 's
		<code>xx*</code>	one or more consecutive <code>x</code> 's
		<code>.*</code>	zero or more characters

Notation	Meaning	Example	Matches
		<code>w.*s</code>	<code>w</code> followed by zero or more characters followed by an <code>s</code>
<code>[ chars ]</code>	any character in <i>chars</i>	<code>[tT]</code>	lower- or uppercase <code>t</code>
		<code>[a-z]</code>	lowercase letter
		<code>[a-zA-Z]</code>	lower- or uppercase letter
<code>[^ chars ]</code>	any character <i>notin chars</i>	<code>[^0-9]</code>	any nonnumeric character
		<code>[^a-zA-Z]</code>	any nonalphabetic character
<code>\{ min, max \}</code>	at least <i>min</i> and at most <i>max</i> occurrences of previous regular expressions	<code>x\{1,5\}</code>	at least 1 and at and at most 5 <code>x</code> 's
		<code>[0-9]\{3,9\}</code>	anywhere from 3 to 9 successive digits
		<code>[0-9]\{3\}</code>	exactly 3 digits
		<code>[0-9]\{3,\}</code>	at least 3 digits
<code>\(...\)</code>	store characters matched between parentheses in next register (1-9)	<code>^\(.\)</code>	first character on line and stores it in register 1
		<code>^\(.\)\1</code>	first and second characters on the line if they're the same

## cut

This section teaches you about a useful command known as `cut`. This command comes in handy when you need to extract (that is, "cut out") various fields of data from a data file or the output of a command. The general format of the `cut` command is

```
cut -cchars file
```

where *chars* specifies what characters you want to extract from each line of *file*. This can consist of a single number, as in `-c5` to extract character 5; a comma-separated list of numbers, as in `-c1,13,50` to extract characters 1, 13, and 50; or a dash-separated range of numbers, as in `-c20-50` to extract characters 20 through 50, inclusive. To extract characters to the end of the line, you can omit the second number of the range; so

```
cut -c5- data
```

extracts characters 5 through the end of the line from each line of `data` and writes the results to standard output.

If *file* is not specified, `cut` reads its input from standard input, meaning that you can use `cut` as a filter in a pipeline.

Let's take another look at the output from the `who` command:

```
$ who
root      console Feb 24 08:54
steve     tty02   Feb 24 12:55
george    tty08   Feb 24 09:15
dawn      tty10   Feb 24 15:55
$
```

As shown, currently four people are logged in. Suppose that you just want to know the names of the logged-in users and don't care about what terminals they are on or when they logged in. You can use

the `cut` command to cut out just the usernames from the `who` command's output:

```
$ who | cut -c1-8      Extract the first 8 characters
root
steve
george
dawn
$
```

The `-c1-8` option to `cut` specifies that characters 1 through 8 are to be extracted from each line of input and written to standard output.

The following shows how you can tack a `sort` to the end of the preceding pipeline to get a sorted list of the logged-in users:

```
$ who | cut -c1-8 | sort
dawn
george
root
steve
$
```

If you wanted to see what terminals were currently being used, you could cut out just the `tty` numbers field from the `who` command's output:

```
$ who | cut -c10-16
console
tty02
tty08
```

```
tty10
```

```
$
```

How did you know that `who` displays the terminal identification in character positions 10 through 16? Simple! You executed the `who` command at your terminal and *counted* out the appropriate character positions. [\[2\]](#)

<sup>[2]</sup> *On some versions of the Unix system, this field starts in character position 12 and not 10.*

You can use `cut` to extract as many different characters from a line as you want. Here, `cut` is used to display just the username and login time of all logged-in users:

```
$ who | cut -c1-8,18-
```

```
root      Feb 24 08:54
```

```
steve     Feb 24 12:55
```

```
george    Feb 24 09:15
```

```
dawn      Feb 24 15:55
```

```
$
```

The option `-c1-8,18-` says "extract characters 1 through 8 (the username) and also characters 18 through the end of the line (the login time)." [\[3\]](#)

<sup>[3]</sup> *Again, on some systems the login time field starts in column 25.*

## The `-d` and `-f` Options

The `cut` command as described previously is useful when you need to extract data from a file or command provided that file or command has a fixed format.

For example, you could use `cut` on the `who` command because you know that the usernames are *always* displayed in character positions 1–8, the terminal in 10–16, and the login time in 18–29. Unfortunately, not all your data will be so well organized! For instance, take a look at the file `/etc/passwd`:

```
$ cat /etc/passwd
```

```
root:*:0:0:The Super User::/usr/bin/ksh
```



```
cron:*:1:1:Cron Daemon for periodic tasks:/:  
bin:*:3:3:The owner of system files:/:  
uucp:*:5:5::/usr/spool/uucp:/usr/lib/uucp/uucico  
asg:*:6:6:The Owner of Assignable Devices:/:  
steve:*:203:100::/users/steve:/usr/bin/ksh  
other:*:4:4:Needed by secure program:/:  
  
$
```

`/etc/passwd` is the master file that contains the usernames of all users on your computer system. It also contains other information such as your user id number, your home directory, and the name of the program to start up when you log in. Getting back to the `cut` command, you can see that the data in this file does not align itself the same way `who`'s output does. So getting a list of all the possible users of your system cannot be done using the `-c` option to `cut`.

One nice thing about the format of `/etc/passwd`, however, is that fields are delimited by a colon character. So although each field may not be the same length from one line to the next, you know that you can "count colons" to get the same field from each line.

The `-d` and `-f` options are used with `cut` when you have data that is delimited by a particular character. The format of the `cut` command in this case becomes

```
cut -dchar -ffields file
```

where *dchar* is the character that delimits each field of the data, and *fields* specifies the fields to be extracted from *file*. Field numbers start at 1, and the same type of formats can be used to specify field numbers as was used to specify character positions before (for example, `-f1,2,8`, `-f1-3`, `-f4-`).

So to extract the names of all users of your system from `/etc/passwd`, you could type the following:

```
$ cut -d: -f1 /etc/passwd      Extract field 1  
  
root  
  
cron  
  
bin  
  
uucp
```

```
asg
steve
other
$
```

Given that the home directory of each user is in field 6, you can associate each user of the system with his or her home directory as shown:

```
$ cut -d: -f1,6 /etc/passwd Extract fields 1 and 6
root:/
cron:/
bin:/
uucp:/usr/spool/uucp
asg:/
steve:/users/steve
other:/
$
```

If the `cut` command is used to extract fields from a file and the `-d` option is not supplied, `cut` uses the tab character as the default field delimiter.

The following depicts a common pitfall when using the `cut` command. Suppose that you have a file called `phonebook` that has the following contents:

```
$ cat phonebook
Alice Chebba    973-555-2015
Barbara Swingle 201-555-9257
Jeff Goldberg   201-555-3378
Liz Stachiw     212-555-2298
```

```
Susan Goldberg 201-555-7776
```

```
Tony Iannino 973-555-1295
```

```
$
```

If you just want to get the names of the people in your phone book, your first impulse would be to use `cut` as shown:

```
$ cut -c1-15 phonebook
```

```
Alice Chebba 97
```

```
Barbara Swingle
```

```
Jeff Goldberg 2
```

```
Liz Stachiw 212
```

```
Susan Goldberg
```

```
Tony Iannino 97
```

```
$
```

Not quite what you want! This happened because the name is separated from the phone number by a tab character and not blank spaces in the `phonebook` file. And as far as `cut` is concerned, tabs count as a single character when using the `-c` option. So `cut` extracts the first 15 characters from each line in the previous example, giving the results as shown.

Given that the fields are separated by tabs, you should use the `-f` option to `cut` instead:

```
$ cut -f1 phonebook
```

```
Alice Chebba
```

```
Barbara Swingle
```

```
Jeff Goldberg
```

```
Liz Stachiw
```

```
Susan Goldberg
```

Tony Iannino

\$

Much better! Recall that you don't have to specify the delimiter character with the `-d` option because `cut` assumes that a tab character is the delimiter by default.

But how do you know in advance whether fields are delimited by blanks or tabs? One way to find out is by trial and error as shown previously. Another way is to type the command

```
sed -n 1 file
```

at your terminal. If a tab character separates the fields, `\t` will be displayed instead of the tab:

```
$ sed -n 1 phonebook
```

```
Alice Chebba\t973-555-2015
```

```
Barbara Swingle\t201-555-9257
```

```
Jeff Goldberg\t201-555-3378
```

```
Liz Stachiw\t212-555-2298
```

```
Susan Goldberg\t201-555-7776
```

```
Tony Iannino\t973-555-1295
```

```
$
```

The output verifies that each name is separated from each phone number by a tab character. `sed` is covered in more detail shortly.

## paste

The `paste` command is sort of the inverse of `cut`: Instead of breaking lines apart, it puts them together. The general format of the `paste` command is

```
paste files
```

where corresponding lines from each of the specified *files* are "pasted" together to form single lines that are then written to standard output. The dash character `-` can be used in *files* to specify that input is from standard input.

Suppose that you have a set of names in a file called `names`:

```
$ cat names
```

```
Tony
```

```
Emanuel
```

```
Lucy
```

```
Ralph
```

```
Fred
```

```
$
```

Suppose that you also have a file called `numbers` that contains corresponding phone numbers for each name in `names`:

```
$ cat numbers
```

```
(307) 555-5356
```

```
(212) 555-3456
```

```
(212) 555-9959
```

```
(212) 555-7741
```

```
(212) 555-0040
```

```
$
```

You can use paste to print the names and numbers side-by-side as shown:

```
$ paste names numbers Paste them together
```

```
Tony      (307) 555-5356
```

```
Emanuel  (212) 555-3456
```

```
Lucy     (212) 555-9959
```

```
Ralph    (212) 555-7741
```

```
Fred     (212) 555-0040
```

```
$
```

Each line from `names` is displayed with the corresponding line from `numbers`, separated by a tab.

The next example illustrates what happens when more than two files are specified:

```
$ cat addresses
```

```
55-23 Vine Street, Miami
```

```
39 University Place, New York
```

```
17 E. 25th Street, New York
```

```
38 Chauncey St., Bensonhurst
```

```
17 E. 25th Street, New York
```

```
$ paste names addresses numbers
```

```
Tony      55-23 Vine Street, Miami      (307) 555-5356
```

```
Emanuel  39 University Place, New York  (212) 555-3456
```

```
Lucy     17 E. 25th Street, New York     (212) 555-9959
```

```
Ralph 38 Chauncey St., Bensonhurst (212) 555-7741
Fred 17 E. 25th Street, New York (212) 555-0040
$
```

## The `-d` Option

If you don't want the fields separated by tab characters, you can specify the `-d` option with the format

```
-dchars
```

where *chars* is one or more characters that will be used to separate the lines pasted together. That is, the first character listed in *chars* will be used to separate lines from the first file that are pasted with lines from the second file; the second character listed in *chars* will be used to separate lines from the second file from lines from the third, and so on.

If there are more files than there are characters listed in *chars*, `paste` "wraps around" the list of characters and starts again at the beginning.

In the simplest form of the `-d` option, specifying just a single delimiter character causes that character to be used to separate *all* pasted fields:

```
$ paste -d '+' names addresses numbers
Tony+55-23 Vine Street, Miami+(307) 555-5356
Emanuel+39 University Place, New York+(212) 555-3456
Lucy+17 E. 25th Street, New York+(212) 555-9959
Ralph+38 Chauncey St., Bensonhurst+(212) 555-7741
Fred+17 E. 25th Street, New York+(212) 555-0040
```

It's always safest to enclose the delimiter characters in single quotes. The reason why will be explained shortly.

## The `-s` Option

The `-s` option tells `paste` to paste together lines from the same file, not from alternate files. If just one file is specified, the effect is to merge all the lines from the file together, separated by tabs, or by the delimiter characters specified with the `-d` option.

```
$ paste -s names          Paste all lines from names
Tony Emanuel Lucy  Ralph  Fred
$ ls | paste -d' ' -s - Paste ls's output, use space as delimiter
addresses intro lotsaspaces names numbers phonebook
$
```

In the preceding example, the output from `ls` is piped to `paste`, which merges the lines (`-s` option) from standard input (`-`), separating each field with a space (`-d' '` option). Of course, you'll recall from [Chapter 2](#), "A Quick Review of the Basics," that the command

```
echo *
```

would have worked just as well (and is certainly more straightforward).



## sed

`sed` is a program used for editing data. It stands for *stream editor*. Unlike `ed`, `sed` cannot be used interactively. However, its commands are similar. The general form of the `sed` command is

```
sed command file
```

where *command* is an `ed`-style command applied to *each* line of the specified *file*. If no file is specified, standard input is assumed. As `sed` applies the indicated command to each line of the input, it writes the results to standard output.

Recall the file `intro` from previous examples:

```
$ cat intro
```

```
The Unix operating system was pioneered by Ken  
Thompson and Dennis Ritchie at Bell Laboratories  
in the late 1960s. One of the primary goals in  
the design of the Unix system was to create an  
environment that promoted efficient program  
development.
```

```
$
```

Suppose that you want to change all occurrences of "Unix" in the text to "UNIX." This can be easily done in `sed` as follows:

```
$ sed 's/Unix/UNIX/' intro    Substitute Unix with UNIX
```

```
The UNIX operating system was pioneered by Ken  
Thompson and Dennis Ritchie at Bell Laboratories  
in the late 1960s. One of the primary goals in
```

the design of the UNIX system was to create an environment that promoted efficient program development.

\$

For now, get into the habit of enclosing your `sed` command in a pair of single quotes. Later, you'll know when the quotes are necessary and when to use double quotes instead.

The `sed` command `s/Unix/UNIX/` is applied to every line of `intro`. Whether or not the line gets changed by the command, it gets written to standard output all the same. Note that `sed` makes no changes to the original input file. To make the changes permanent, you must redirect the output from `sed` into a temporary file and then move the file back to the old one:

```
$ sed 's/Unix/UNIX/' intro > temp Make the changes
```

```
$ mv temp intro And now make them permanent
```

\$

Always make sure that the correct changes were made to the file before you overwrite the original; a `cat` of `temp` could have been included between the two commands shown previously to ensure that the `sed` succeeded as planned.

If your text included more than one occurrence of "Unix" on a line, the preceding `sed` would have changed just the first occurrence on each line to "UNIX." By appending the *global*/option `g` to the end of the `s` command, you can ensure that multiple occurrences of the string on a line will be changed. In this case, the `sed` command would read

```
$ sed 's/Unix/UNIX/g' intro > temp
```

Suppose that you wanted to extract just the usernames from the output of `who`. You already know how to do that with the `cut` command:

```
$ who | cut -c1-8
```

```
root
```

```
ruth
```

```
steve
```

```
pat
```

```
$
```

Alternatively, you can use `sed` to delete all the characters from the first blank space (that marks the end of the username) through the end of the line by using a regular expression in the edit command:

```
$ who | sed 's/ .*$//'
```

```
root
```

```
ruth
```

```
steve
```

```
pat
```

```
$
```

The `sed` command says to substitute a blank space followed by any characters up to the end of the line (`.*$`) with *nothing* (`/`); that is, delete the characters from the first blank to the end of the line from each line of the input.

## The `-n` Option

We pointed out that `sed` always writes each line of input to standard output, whether or not it gets changed. Sometimes, however, you'll want to use `sed` just to extract some lines from a file. For such purposes, use the `-n` option. This option tells `sed` that you don't want it to print any lines unless explicitly told to do so. This is done with the `p` command. By specifying a line number or range of line numbers, you can use `sed` to selectively print lines of text. So, for example, to print just the first two lines from a file, the following could be used:

```
$ sed -n '1,2p' intro           Just print the first 2 lines
```

```
The UNIX operating system was pioneered by Ken
```

```
Thompson and Dennis Ritchie at Bell Laboratories
```

```
$
```

If, instead of line numbers, you precede the `p` command with a string of characters enclosed in slashes, `sed` prints just those lines from standard input that contain those characters. The following example shows how `sed` can be used to display just the lines that contain a particular string:

```
$ sed -n '/UNIX/p' intro    Just print lines containing UNIX
```

```
The UNIX operating system was pioneered by Ken
```

```
the design of the UNIX system was to create an
```

```
$
```

## Deleting Lines

To delete entire lines of text, use the `d` command. By specifying a line number or range of numbers, you can delete specific lines from the input. In the following example, `sed` is used to delete the first two lines of text from `intro`:

```
$ sed '1,2d' intro        Delete lines 1 and 2
```

```
in the late 1960s. One of the primary goals in
```

```
the design of the UNIX system was to create an
```

```
environment that promoted efficient program
```

```
development.
```

```
$
```

Remembering that by default `sed` writes all lines of the input to standard output, the remaining lines in text—that is, lines 3 through the end—simply get written to standard output.

By preceding the `d` command with a string of text, you can use `sed` to delete all lines that contain that text. In the following example, `sed` is used to delete all lines of text containing the word `UNIX`:

```
$ sed '/UNIX/d' intro    Delete all lines containing UNIX
```

```
Thompson and Dennis Ritchie at Bell Laboratories
```

in the late 1960s. One of the primary goals in environment that promoted efficient program development.

\$

The power and flexibility of `sed` goes far beyond what we've shown here. `sed` has facilities that enable you to loop, build text in a buffer, and combine many commands into a single editing script. [Table 4.2](#) shows some more examples of `sed` commands.

Table 4.2. `sed` Examples

<code>sed</code> Command	Description
<code>sed '5d'</code>	Delete line 5
<code>sed '/[Tt]est/d'</code>	Delete all lines containing <code>Test</code> or <code>test</code>
<code>sed -n '20,25p' text</code>	Print only lines 20 through 25 from <code>text</code>
<code>sed '1,10s/unix/UNIX/g' intro</code>	Change <code>unix</code> to <code>UNIX</code> wherever it appears in the first 10 lines of <code>intro</code>
<code>sed '/jan/s/-1/-5/'</code>	Change the first <code>-1</code> to <code>-5</code> on all lines containing <code>jan</code>
<code>sed 's/.../' data</code>	Delete the first three characters from each line of <code>data</code>
<code>sed 's/...\$/' data</code>	Delete the last 3 characters from each line of <code>data</code>
<code>sed -n 'l' text</code>	Print all lines from <code>text</code> , showing nonprinting characters as <code>\///</code> (where <code>///</code> is the octal value of the character), and tab characters as <code>\t</code>

**tr**

The `tr` filter is used to translate characters from standard input. The general form of the command is

```
tr from-chars to-chars
```

where *from-chars* and *to-chars* are one or more single characters. Any character in *from-chars* encountered on the input will be translated into the corresponding character in *to-chars*. The result of the translation is written to standard output.

In its simplest form, `tr` can be used to translate one character into another. Recall the file `intro` from earlier in this chapter:

```
$ cat intro
```

```
The UNIX operating system was pioneered by Ken  
Thompson and Dennis Ritchie at Bell Laboratories  
in the late 1960s. One of the primary goals in  
the design of the UNIX system was to create an  
environment that promoted efficient program  
development.
```

```
$
```

The following shows how `tr` can be used to translate all letter e's to x's:

```
$ tr e x < intro
```

```
Thx UNIX opxrating systxm was pionxxrxd by Kxn  
Thompson and Dxnnis Ritchix at Bxll Laboratorixs  
in thx latx 1960s. Onx of thx primary goals in
```

the design of the UNIX system was to create an environment that promoted efficient program development.

\$

The input to `tr` must be redirected from the file `intro` because `tr` always expects its input to come from standard input. The results of the translation are written to standard output, leaving the original file untouched. Showing a more practical example, recall the pipeline that you used to extract the usernames and home directories of everyone on the system:

```
$ cut -d: -f1,6 /etc/passwd
```

```
root: /
```

```
cron: /
```

```
bin: /
```

```
uucp: /usr/spool/uucp
```

```
asg: /
```

```
steve: /users/steve
```

```
other: /
```

```
$
```

You can translate the colons into tab characters to produce a more readable output simply by tacking an appropriate `tr` command to the end of the pipeline:

```
$ cut -d: -f1,6 /etc/passwd | tr : ' \t '
```

```
root    /
```

```
cron    /
```

```
bin     /
```

```
uucp    /usr/spool/uucp
```

```
asg /
steve /users/steve
other /
$
```

Enclosed between the single quotes is a tab character (even though you can't see it—just take our word for it). It must be enclosed in quotes to keep it from the shell and give `tr` a chance to see it.

The octal representation of a character can be given to `tr` in the format

```
\nnn
```

where *nnn* is the octal value of the character. For example, the octal value of the tab character is 11. If you are going to use this format, be sure to enclose the character in quotes. The `tr` command

```
tr : '\11'
```

translates all colons to tabs, just as in the preceding example. [Table 4.3](#) lists characters that you'll often want to specify in octal format.

Table 4.3. Octal Values of Some ASCII Characters

Character	Octal Value
Bell	7
Backspace	10
Tab	11
Newline	12
Linefeed	12
Formfeed	14
Carriage Return	15
Escape	33



In the following example, `tr` takes the output from `date` and translates all spaces into newline characters. The net result is that each field of output from `date` appears on a different line.

```
$ date | tr ' ' '\n' Translate spaces to newlines
```

```
Sun
```

```
Jul
```

```
28
```

```
19:13:46
```

```
EDT
```

```
2002
```

```
$
```

`tr` can also take ranges of characters to translate. For example, the following shows how to translate all lowercase letters in `intro` to their uppercase equivalents:

```
$ tr '[a-z]' '[A-Z]' < intro
```

```
THE UNIX OPERATING SYSTEM WAS PIONEERED BY KEN
```

```
THOMPSON AND DENNIS RITCHIE AT BELL LABORATORIES
```

```
IN THE LATE 1960S. ONE OF THE PRIMARY GOALS IN
```

```
THE DESIGN OF THE UNIX SYSTEM WAS TO CREATE AN
```

```
ENVIRONMENT THAT PROMOTED EFFICIENT PROGRAM
```

```
DEVELOPMENT.
```

```
$
```

The character ranges `[a-z]` and `[A-Z]` are enclosed in quotes to keep the shell from replacing the first range with all the files in your directory named `a` through `z`, and the second range with all the files in your directory named `A` through `Z`. (What do you think happens if no such files exist?)

By reversing the two arguments to `tr`, you can use it to translate all uppercase letters to lowercase:

```
$ tr '[A-Z]' '[a-z]' < intro
```

```
the unix operating system was pioneered by ken  
thompson and dennis ritchie at bell laboratories  
in the late 1960s. one of the primary goals in  
the design of the unix system was to create an  
environment that promoted efficient program  
development.
```

```
$
```

## The `-s` Option

You can use the `-s` option to `tr` to "squeeze" out multiple occurrences of characters in *to-chars*. In other words, if more than one consecutive occurrence of a character specified in *to-chars* occurs after the translation is made, the characters will be replaced by a single character.

For example, the following command translates all colons into tab characters, replacing multiple tabs with single tabs:

```
tr -s ':' '\11'
```

So one colon or several consecutive colons on the input will be replaced by a *single* tab character on the output.

Suppose that you have a file called `lotsaspaces` that has the contents as shown:

```
$ cat lotsaspaces
```

```
This      is  an example  of a  
file  that contains      a lot  
of  blank spaces.
```

```
$
```

You can use `tr` to squeeze out the multiple spaces by using the `-s` option and by specifying a single space character as the first and second argument:

```
$ tr -s ' ' ' ' < lotsaspaces
```

```
This is an example of a  
file that contains a lot  
of blank spaces.  
$
```

The options to `tr` in effect say "translate space characters to space characters, replacing multiple spaces in the output by a single space."

## The `-d` Option

`tr` can also be used to delete single characters from a stream of input. The general format of `tr` in this case is

```
tr -d from-chars
```

where any single character listed in *from-chars* will be deleted from standard input. In the following example, `tr` is used to delete all spaces from the file `intro`:

```
$ tr -d ' ' < intro
```

```
TheUNIXoperatingSystemwaspioneeredbyKen  
ThompsonandDennisRitchieatBellLaboratories  
inthelate1960s.Oneoftheprimarygoalsin  
thedesignoftheUNIXSystemwastocreatean  
environmentthatpromotedefficientprogram  
development.
```

```
$
```

Of course, you probably realize that you could have also used `sed` to achieve the same results:

```
$ sed 's/ //g' intro
```

```
TheUNIXoperatingsystemwaspioneeredbyKen  
ThompsonandDennisRitchieatBellLaboratories  
inthelate1960s.Oneoftheprimarygoalsin  
thedesignoftheUNIXsystemwastocreatean  
environmentthatpromotedefficientprogram  
development.
```

```
$
```

This is not atypical for the Unix system; there's almost always more than one approach to solving a particular problem. In the case we just saw, either approach is satisfactory (that is, `tr` or `sed`); however, `tr` is probably a better choice in this case because it is a much smaller program and likely to execute a bit faster.

[Table 4.4](#) summarizes how to use `tr` for translating and deleting characters. Bear in mind that `tr` works only on *single* characters. So if you need to translate anything longer than a single character (say all occurrences of `unix` to `UNIX`), you have to use a different program such as `sed` instead.

Table 4.4. `tr` Examples

<code>tr</code> Command	Description
<code>tr 'X' 'x'</code>	Translate all capital X's to small x's
<code>tr '()' '{}'</code>	Translate all open parens to open braces, all closed parens to closed braces
<code>tr '[a-z]' '[A-Z]'</code>	Translate all lowercase letters to uppercase
<code>tr '[A-Z]' '[N-ZA-M]'</code>	Translate uppercase letters A–M to N–Z, and N–Z to A–M, respectively
<code>tr ' ' ' '</code>	Translate all tabs (character in first pair of quotes) to spaces

**tr** Command

Description

`tr -s ' ' ' '`

Translate multiple spaces to single spaces

`tr -d '\14'`

Delete all formfeed (octal 14) characters

`tr -d '[0-9]'`

Delete all digits

**Team LiB**

[◀ PREVIOUS](#)

[NEXT ▶](#)

## grep

`grep` allows you to search one or more files for particular character patterns. The general format of this command is

```
grep pattern files
```

Every line of each file that contains *pattern* is displayed at the terminal. If more than one file is specified to `grep`, each line is also immediately preceded by the name of the file, thus enabling you to identify the particular file that the pattern was found in.

Let's say that you want to find every occurrence of the word `shell` in the file `ed.cmd`:

```
$ grep shell ed.cmd
```

```
files, and is independent of the shell.
```

```
to the shell, just type in a q.
```

```
$
```

This output indicates that two lines in the file `ed.cmd` contain the word `shell`.

If the pattern does not exist in the specified file(s), the `grep` command simply displays nothing:

```
$ grep cracker ed.cmd
```

```
$
```

You saw in the section on [sed](#) how you could print all lines containing the string `UNIX` from the file `intro` with the command

```
sed -n '/UNIX/p' intro
```

But you could also use the following `grep` command to achieve the same result:

```
grep UNIX intro
```

Recall the `phonebook` file from before:

```
$ cat phone_book
```

```
Alice Chebba    973-555-2015
```

```
Barbara Swingle 201-555-9257
```

```
Jeff Goldberg   201-555-3378
```

```
Liz Stachiw     212-555-2298
```

```
Susan Goldberg  201-555-7776
```

```
Tony Iannino    973-555-1295
```

```
$
```

When you need to look up a particular phone number, the `grep` command comes in handy:

```
$ grep Susan phone_book
```

```
Susan Goldberg  201-555-7776
```

```
$
```

The `grep` command is useful when you have a lot of files and you want to find out which ones contain certain words or phrases. The following example shows how the `grep` command can be used to search for the word `shell` in `all` files in the current directory:

```
$ grep shell *
```

```
cmdfiles:shell that enables sophisticated
```

```
ed.cmd:files, and is independent of the shell.
```

```
ed.cmd:to the shell, just type in a q.
grep.cmd:occurrence of the word shell:
grep.cmd:$ grep shell *
grep.cmd:every use of the word shell.
$
```

As noted, when more than one file is specified to `grep`, each output line is preceded by the name of the file containing that line.

It's generally a good idea to enclose your `grep` pattern inside a pair of *single* quotes to "protect" it from the shell. For instance, if you want to find all the lines containing asterisks inside the file `stars`, typing

```
grep * stars
```

does not work as expected because the shell sees the asterisk and automatically substitutes the names of all the files in your current directory!

```
$ ls
circles
polka.dots
squares
stars
stripes
$ grep * stars
$
```

In this case, the shell took the asterisk and substituted the list of files in your current directory. Then it started execution of `grep`, which took the first argument (`circles`) and tried to find it in the files specified by the remaining arguments, as shown in [Figure 4.1](#).



Figure 4.1. `grep * stars`.

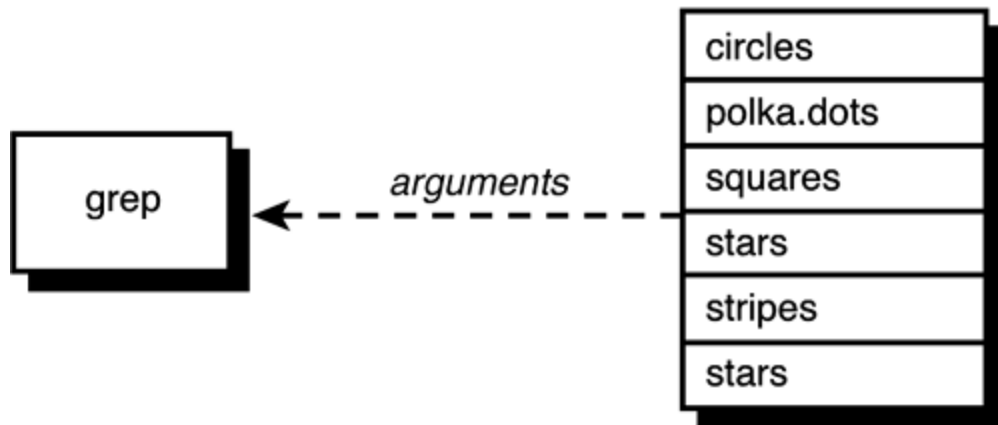

Enclosing the asterisk in quotes, however, removes its special meaning from the shell:

```
$ grep '*' stars
```

The asterisk (\*) is a special character that

```
*****
```

```
5 * 4 = 20
```

```
$
```

The quotes told the shell to leave the enclosed characters alone. It then started execution of `grep`, passing it the two arguments `*` (*without* the surrounding quotes; the shell removes them in the process) and `stars` (see [Figure 4.2](#)).

Figure 4.2. `grep '*' stars`.

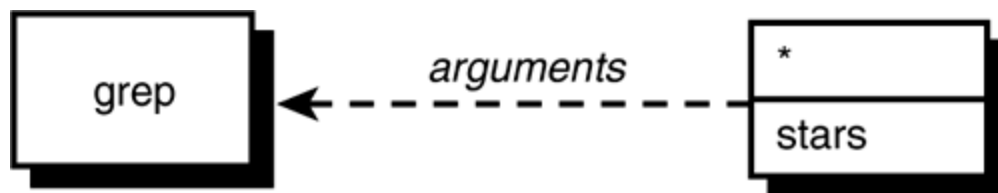

There are characters other than `*` that otherwise have a special meaning and must be quoted when used in a pattern. The whole topic of how quotes are handled by the shell is fascinating; an entire chapter—[Chapter 6](#), "Can I Quote You on That?"—is devoted to it.

`grep` takes its input from standard input if no filename is specified. So you can use `grep` on the other side of a pipe to scan through the output of a command for something. For example, suppose that

you want to find out whether the user `jim` is logged in. You can use `grep` to search through `who`'s output:

```
$ who | grep jim
jim          tty16          Feb 20 10:25
$
```

Note that by not specifying a file to search, `grep` automatically scans its standard input. Naturally, if the user `jim` were not logged in, you simply would get back a new prompt because `grep` would not find `jim` in `who`'s output:

```
$ who | grep jim
$
```

## Regular Expressions and `grep`

Let's take another look at the `intro` file:

```
$ cat intro
The UNIX operating system was pioneered by Ken
Thompson and Dennis Ritchie at Bell Laboratories
in the late 1960s. One of the primary goals in
the design of the UNIX system was to create an
environment that promoted efficient program
development.
$
```

`grep` allows you to specify your pattern using regular expressions as in `ed`. Given this information, it means that you can specify the pattern

```
[tT]he
```

to have `grep` search for either a lower- or uppercase `T` followed by the characters `he`.

So here's how to `grep` out all the lines containing the characters `the` or `The`:

```
$ grep '[tT]he' intro
```

```
The UNIX operating system was pioneered by Ken  
in the late 1960s. One of the primary goals in  
the design of the UNIX system was to create an  
$
```

The `-i` option to `grep` indicates that upper- and lowercase letters are not to be distinguished in the matching process. That is, the command

```
grep -i 'the' intro
```

tells `grep` to ignore case when matching the pattern against the lines in `intro`. Therefore, lines containing `the` or `The` will be printed, as will lines containing `THE`, `THE`, `tHE`, and so on.

[Table 4.5](#) shows other types of regular expressions that you can specify to `grep` and the types of patterns they'll match.

Table 4.5. Some `grep` Examples

Command	Prints
<code>grep '[A-Z]' list</code>	Lines from <code>list</code> containing a capital letter
<code>grep '[0-9]' data</code>	Lines from <code>data</code> containing a number
<code>grep '[A-Z]...[0-9]' list</code>	Lines from <code>list</code> containing five-character patterns that start with a capital letter and end with a digit
<code>grep '\.pic\$' filelist</code>	Lines from <code>filelist</code> that end in <code>.pic</code>

## The `-v` Option

Sometimes you're interested not in finding the lines that contain a specified pattern, but those that *don't*. To do this with `grep` is simple: You use the `-v` option. In the next example, `grep` is used to find all the lines in `intro` that don't contain the characters `UNIX`.

```
$ grep -v 'UNIX' intro Print all lines that don't contain UNIX
```

```
Thompson and Dennis Ritchie at Bell Laboratories
```

```
in the late 1960s. One of the primary goals in
```

```
environment that promoted efficient program
```

```
development.
```

```
$
```

## The `-l` Option

At times, you may not want to see the actual lines that match a pattern but may be interested in knowing only the names of the files that contain the pattern. For example, suppose that you have a set of C programs in your current directory (these filenames end with the characters `.c`), and you want to know which files use a variable called `Move_history`. The following example shows one way of finding the answer:

```
$ grep 'Move_history' *.c Find Move_history in all C source files
```

```
exec.c:MOVE      Move_history[200] = {0};
```

```
exec.c:      cpymove(&Move_history[Number_half_moves -1],
```

```
exec.c: undo_move(&Move_history[Number_half_moves-1],;
```

```
exec.c: cpymove(&last_move,&Move_history[Number_half_moves-1]);
```

```
exec.c: convert_move(&Move_history[Number_half_moves-1]),
```

```
exec.c:      convert_move(&Move_history[i-1]),
```

```
exec.c: convert_move(&Move_history[Number_half_moves-1]),
```

```
makemove.c:IMPORT MOVE Move_history[];
```

```
makemove.c:      if ( Move_history[j].from != BOOK (i,j,from) OR
makemove.c:      Move_history[j] .to != BOOK (i,j,to) )
testch.c:GLOBAL MOVE Move_history[100] = {0};
testch.c:      Move_history[Number_half_moves-1].from = move.from;
testch.c:      Move_history[Number_half_moves-1].to = move.to;
$
```

Sifting through the preceding output, you discover that three files—`exec.c`, `makemove.c`, and `testch.c`—use the variable.

The `-l` option to `grep` gives you just a list of files that contain the specified pattern, not the matching lines from the files:

```
$ grep -l 'Move_history' *.c List the files that contain Move_history
exec.c
makemove.c
testch.c
$
```

Because `grep` conveniently lists the files one per line, you can pipe the output from `grep -l` into `wc` to count the *number of files* that contain a particular pattern:

```
$ grep -l 'Move_history' *.c | wc -l
3
$
```

So the preceding says that precisely three C program files reference the variable `Move_history`. (What are you counting if you use `grep` *without* the `-l` option?)

## The `-n` Option

If the `-n` option is used with `grep`, each line from the file that matches the specified pattern is preceded by its relative line number in the file. From previous examples, you saw that the file `testch.c` was one of the three files that referenced the variable `Move_history`; the following shows how you can pinpoint the precise lines in the file that reference the variable:

```
$ grep -n 'Move_history' testch.c  Precede matches with line numbers
13:GLOBAL MOVE Move_history[100] = {0};
197:    Move_history[Number_half_moves-1].from = move.from;
198:    Move_history[Number_half_moves-1].to = move.to;
$
```

As you can see, `Move_history` is used on lines 13, 197, and 198 in `testch.c`.

## sort

You're familiar with the basic operation of `sort`:

```
$ sort names
```

```
Charlie
```

```
Emanuel
```

```
Fred
```

```
Lucy
```

```
Ralph
```

```
Tony
```

```
Tony
```

```
$
```

By default, `sort` takes each line of the specified input file and sorts it into ascending order. Special characters are sorted according to the internal encoding of the characters. For example, on a machine that encodes characters in ASCII, the space character is represented internally as the number 32, and the double quote as the number 34. This means that the former would be sorted before the latter. Note that the sorting order is implementation dependent, so although you are generally assured that `sort` will perform as expected on alphabetic input, the ordering of numbers, punctuation, and special characters is not always guaranteed. We will assume we're working with the ASCII character set in all our examples here.

`sort` has many options that provide more flexibility in performing your sort. We'll just describe a few of the options here.

## The `-u` Option

The `-u` option tells `sort` to eliminate duplicate lines from the output.

```
$ sort -u names
```

```
Charlie
```

```
Emanuel
Fred
Lucy
Ralph
Tony
$
```

Here you see that the duplicate line that contained **Tony** was eliminated from the output.

## The **-r** Option

Use the **-r** option to *reverse* the order of the sort:

```
$ sort -r names           Reverse sort
Tony
Tony
Ralph
Lucy
Fred
Emanuel
Charlie
$
```

## The **-o** Option

By default, **sort** writes the sorted data to standard output. To have it go into a file, you can use output redirection:

```
$ sort names > sorted_names
```



```
$
```

Alternatively, you can use the `-o` option to specify the output file. Simply list the name of the output file right after the `-o`:

```
$ sort names -o sorted_names
```

```
$
```

This sorts `names` and writes the results to `sorted_names`.

Frequently, you want to sort the lines in a file and have the sorted data replace the original. Typing

```
$ sort names > names
```

```
$
```

won't work—it ends up wiping out the `names` file. However, with the `-o` option, it is okay to specify the same name for the output file as the input file:

```
$ sort names -o names
```

```
$ cat names
```

```
Charlie
```

```
Emanuel
```

```
Fred
```

```
Lucy
```

```
Ralph
```

```
Tony
```

```
Tony
```

```
$
```

## The `-n` Option

Suppose that you have a file containing pairs of  $(x, y)$  data points as shown:

```
$ cat data
5      27
2      12
3      33
23     2
-5     11
15     6
14     -9
$
```

Suppose that you want to feed this data into a plotting program called `plotdata`, but that the program requires that the incoming data pairs be sorted in increasing value of  $x$  (the first value on each line).

The `-n` option to `sort` specifies that the first field on the line is to be considered a *number*, and the data is to be sorted arithmetically. Compare the output of `sort` used first without the `-n` option and then with it:

```
$ sort data
-5     11
14     -9
15     6
2      12
23     2
3      33
```

```
5      27
$ sort -n data      Sort arithmetically
-5     11
2      12
3      33
5      27
14     -9
15     6
23     2
$
```

## Skipping Fields

If you had to sort your `data` file by the `y` value—that is, the second number in each line—you could tell `sort` to skip past the first number on the line by using the option

```
+1n
```

instead of `-n`. The `+1` says to skip the first field. Similarly, `+5n` would mean to skip the first five fields on each line and then sort the data numerically. Fields are delimited by space or tab characters by default. If a different delimiter is to be used, the `-t` option must be used.

```
$ sort +1n data      Skip the first field in the sort
14     -9
23     2
15     6
-5     11
2      12
```

```
5      27
3      33
$
```

## The `-t` Option

As mentioned, if you skip over fields, `sort` assumes that the fields being skipped are delimited by space or tab characters. The `-t` option says otherwise. In this case, the character that follows the `-t` is taken as the delimiter character.

Look at our sample password file again:

```
$ cat /etc/passwd

root:*:0:0:The super User:/:usr/bin/ksh
steve:*:203:100:/:users/steve:/usr/bin/ksh
bin:*:3:3:The owner of system files:/:
cron:*:1:1:Cron Daemon for periodic tasks:/:
george:*:75:75:/:users/george:/usr/lib/rsh
pat:*:300:300:/:users/pat:/usr/bin/ksh
uucp:*:5:5:/:usr/spool/uucppublic:/usr/lib/uucp/uucico
asg:*:6:6:The Owner of Assignable Devices:/:
sysinfo:*:10:10:Access to System Information:/:usr/bin/sh
mail:*:301:301:/:usr/mail:

$
```

If you wanted to sort this file by username (the first field on each line), you could just issue the command

```
sort /etc/passwd
```

To sort the file instead by the third colon-delimited field (which contains what is known as your *user id*), you would want an arithmetic sort, skipping the first two fields (`+2n`), specifying the colon character as the field delimiter (`-t:`):

```
$ sort +2n -t: /etc/passwd Sort by user id

root:*:0:0:The Super User:/:usr/bin/ksh

cron:*:1:1:Cron Daemon for periodic tasks:/:

bin:*:3:3:The owner of system files:/:

uucp:*:5:5:/:usr/spool/uucppublic:/usr/lib/uucp/uucico

asg:*:6:6:The Owner of Assignable Devices:/:

sysinfo:*:10:10:Access to System Information:/:usr/bin/sh

george:*:75:75:/:users/george:/usr/lib/rsh

steve:*:203:100:/:users/steve:/usr/bin/ksh

pat:*:300:300:/:users/pat:/usr/bin/ksh

mail:*:301:301:/:usr/mail:

$
```

Here we've emboldened the third field of each line so that you can easily verify that the file was sorted correctly by user id.

## Other Options

Other options to `sort` enable you to skip characters within a field, specify the field to *end* the sort on, merge sorted input files, and sort in "dictionary order" (only letters, numbers, and spaces are used for the comparison). For more details on these options, look under `sort` in your *Unix User's Manual*.

## uniq

The `uniq` command is useful when you need to find duplicate lines in a file. The basic format of the command is

```
uniq in_file out_file
```

In this format, `uniq` copies *in\_file* to *out\_file*, removing any duplicate lines in the process. `uniq`'s definition of duplicated lines are *consecutive-occurring* lines that match exactly.

If *out\_file* is not specified, the results will be written to standard output. If *in\_file* is also not specified, `uniq` acts as a filter and reads its input from standard input.

Here are some examples to see how `uniq` works. Suppose that you have a file called `names` with contents as shown:

```
$ cat names
```

```
Charlie
```

```
Tony
```

```
Emanuel
```

```
Lucy
```

```
Ralph
```

```
Fred
```

```
Tony
```

```
$
```

You can see that the name `Tony` appears twice in the file. You can use `uniq` to "remove" such duplicate entries:

```
$ uniq names          Print unique lines
```

```
Charlie
Tony
Emanuel
Lucy
Ralph
Fred
Tony
$
```

`Tony` still appears twice in the preceding output because the multiple occurrences are not consecutive in the file, and thus `uniq`'s definition of duplicate is not satisfied. To remedy this situation, `sort` is often used to get the duplicate lines adjacent to each other. The result of the sort is then run through `uniq`:

```
$ sort names | uniq
Charlie
Emanuel
Fred
Lucy
Ralph
Tony
$
```

So the `sort` moves the two `Tony` lines together, and then `uniq` filters out the duplicate line (recall that `sort` with the `-u` option performs precisely this function).

## The `-d` Option

Frequently, you'll be interested in finding the duplicate entries in a file. The `-d` option to `uniq` should be used for such purposes: It tells `uniq` to write only the duplicated lines to *out\_file* (or standard output). Such lines are written just once, no matter how many consecutive occurrences there are.

```
$ sort names | uniq -d      List duplicate lines
```

```
Tony
```

```
$
```

As a more practical example, let's return to our `/etc/passwd` file. This file contains information about each user on the system. It's conceivable that over the course of adding and removing users from this file that perhaps the same username has been inadvertently entered more than once. You can easily find such duplicate entries by first sorting `/etc/passwd` and piping the results into `uniq -d` as done previously:

```
$ sort /etc/passwd | uniq -d  Find duplicate entries in /etc/passwd
```

```
$
```

So there are no duplicate entries. But we think that you really want to find duplicate entries for the same username. This means that you want to just look at the first field from each line of `/etc/passwd` (recall that the leading characters of each line of `/etc/passwd` up to the colon are the username). This can't be done directly through an option to `uniq`, but can be accomplished indirectly by using `cut` to extract the username from each line of the password file before sending it to `uniq`.

```
$ sort /etc/passwd | cut -f1 -d: | uniq -d  Find duplicates
```

```
cem
```

```
harry
```

```
$
```

So there are multiple entries in `/etc/passwd` for `cem` and `harry`. If you wanted more information on the particular entries, you could `grep` them from `/etc/passwd`:

```
$ grep -n 'cem' /etc/passwd
```

```
20:cem:*:91:91::/users/cem:
```

```
166:cem:*:91:91::/users/cem:
```



```
$ grep -n 'harry' /etc/passwd
29:harry:*:103:103:Harry Johnson:/users/harry:
79:harry:*:90:90:Harry Johnson:/users/harry:
$
```

The `-n` option was used to find out where the duplicate entries occur. In the case of `cem`, there are two entries on lines 20 and 166; in `harry`'s case, the two entries are on lines 29 and 79.

If you now want to remove the second `cem` entry, you could use `sed`:

```
$ sed '166d' /etc/passwd > /tmp/passwd    Remove duplicate
$ mv /tmp/passwd /etc/passwd
mv: /etc/passwd: 444 modey
mv: cannot unlink /etc/passwd
$
```

Naturally, `/etc/passwd` is one of the most important files on a Unix system. As such, only the *superuser* is allowed to write to the file. That's why the `mv` command failed.

## Other Options

The `-c` option to `uniq` behaves like `uniq` with no options (that is, duplicate lines are removed), except that each output line gets preceded by a count of the number of times the line occurred in the input.

```
$ sort names | uniq -c    Count line occurrences
 1 Charlie
 1 Emanuel
 1 Fred
 1 Lucy
 1 Ralph
```

\$

Two other options that won't be described enable you to tell `uniq` to ignore leading characters/fields on a line. For more information, consult your *Unix User's Manual*.

We would be remiss if we neglected to mention the programs `awk` and `perl` that can be useful when writing shell programs. However, to do justice to these programs requires more space than we can provide in this text. We'll refer you to the document *Awk—A Pattern Scanning and Processing Language*, by Aho, et al., in the *Unix Programmer's Manual, Volume 11* for a description of `awk`. Kernighan and Pike's *The Unix Programming Environment* (Prentice Hall, 1984) contains a detailed discussion of `awk`. *Learning Perl* and *Programming Perl*, both from O'Reilly and Associates, present a good tutorial and reference on the language, respectively.

## Exercises

1: What will be matched by the following regular expressions?

```
x*           [0-9]\{3\}
xx*         [0-9]\{3,5\}
x\{1,5\}    [0-9]\{1,3\},[0-9]\{3\}
x\{5,\}     ^\...
x\{10\}     [A-Za-z_][A-Za-z_0-9]*
[0-9]       \([A-Za-z0-9]\{1,\}\)\1
[0-9]*      ^Begin$
[0-9][0-9][0-9]  ^\(.\)\.*\1$
```

2: What will be the effect of the following commands?

```
who | grep 'mary'
who | grep '^mary'
grep '[Uu]nix' ch?/*
ls -l | sort +4n
sed '/^$/d' text > text.out
sed 's/\([Uu]nix\)/\1(TM)/g' text > text.out
date | cut -c12-16
date | cut -c5-11,25- | sed 's/\([0-9]\{1,2\}\)/\1,/'
```

3: Write the commands to

- a. Find all logged-in users with usernames of at least four characters.
- b. Find all users on your system whose user ids are greater than 99.
- c. Find the number of users on your system whose user ids are greater than 99.
- d. List all the files in your directory in decreasing order of file size.

**Team LiB**

◀ PREVIOUS

NEXT ▶

# Chapter 5. And Away We Go

## IN THIS CHAPTER

- [Command Files](#)
- [Variables](#)
- [Built-in Integer Arithmetic](#)
- [Exercises](#)

Based on the discussions in [Chapter 3](#), "What Is the Shell?," you should realize that whenever you type something like

```
who | wc -l
```

that you are actually programming in the shell! That's because the shell is interpreting the command line, recognizing the pipe symbol, connecting the output of the first command to the input of the second, and initiating execution of both commands.

In this chapter, you'll learn how to write your own commands and how to use shell *variables*.

## Command Files

A shell program can be typed directly at the terminal, as in

```
$ who | wc -l
```

or it can be first typed into a file and then the file can be executed by the shell. For example, suppose that you need to find out the number of logged-in users several times throughout the day. It's not unreasonable to type in the preceding pipeline each time you want the information, but for the sake of example, let's type this pipeline into a file. We'll call the file `nu` (for *number of users*), and its contents will be just the pipeline shown previously:

```
$ cat nu
```

```
who | wc -l
```

```
$
```

To execute the commands contained inside the file `nu`, all you now have to do is type `nu` as the command name to the shell: [\[1\]](#)

<sup>[1]</sup> *Note that the error produced here varies between different shells.*

```
$ nu
```

```
sh: nu: cannot execute
```

```
$
```

Oops! We forgot to mention one thing. Before you can execute a program this way, you must change the file's permissions and make it *executable*. This is done with the change mode command `chmod`. To add execute permission to the file `nu`, you simply type

```
chmod +x file(s)
```

The `+x` says make the *file(s)* that follow executable. The shell requires that a file be *both* readable and executable by you before you can execute it.

```
$ ls -l nu
-rw-rw-r--  1 steve  steve    12 Jul 10 11:42 nu
$ chmod +x nu      Make it executable
$ ls -l nu
-rwxrwxr-x  1 steve  steve    12 Jul 10 11:42 nu
$
```

Now that you've made it executable, try it again:

```
$ nu
      8
$
```

This time it worked.

You can put any commands at all inside a file, make the file executable, and then execute its contents simply by typing its name to the shell. It's that simple and that powerful.

The standard shell mechanisms such as I/O redirection and pipes can be used on your own programs as well:

```
$ nu > tally
$ cat tally
      8
$
```

Suppose that you're working on a proposal called `sys.caps` and that the following command sequence is needed every time you want to print a new copy of the proposal:

```
tbl sys.caps | nroff -mm -Tlp | lp
```

Once again, you can save yourself some typing by simply placing this command sequence into a file—let's call it `run`—making it executable, and then just typing the name `run` whenever you want to get a new copy of the proposal:

```
$ cat run
```

```
tbl sys.caps | nroff -mm -Tlp | lp
```

```
$ chmod +x run
```

```
$ run
```

```
request id is laser1-15 (standard input)
```

```
$
```

(The `request id` message is issued by the `lp` command.) For the next example, suppose that you want to write a shell program called `stats` that prints the date and time, the number of users logged in, and your current working directory. You know that the three command sequences you need to use to get this information are `date`, `who | wc -l`, and `pwd`:

```
$ cat stats
```

```
date
```

```
who | wc -l
```

```
pwd
```

```
$ chmod +x stats
```

```
$ stats
```

*Try it out*

```
Wed Jul 10 11:55:50 EDT 2002
```



```
/users/steve/documents/proposals
```

```
$
```

You can add some `echo` commands to `stats` to make the output a bit more informative:

```
$ cat stats
```

```
echo The current date and time is:
```

```
date
```

```
echo
```

```
echo The number of users on the system is:
```

```
who | wc -l
```

```
echo
```

```
echo Your current working directory is:
```

```
pwd
```

```
$ stats Execute it
```

```
The current date and time is:
```

```
Wed Jul 10 12:00:27 EDT 2002
```

```
The number of users on the system is:
```

```
13
```

```
Your current working directory is:
```

```
/users/steve/documents/proposals
```

```
$
```

Recall that `echo` without any arguments simply skips a line in the display. Shortly, you'll see how to have the message and the data displayed on the same line, like this:

The current date and time is: Wed Jul 10 12:00:27 EDT 2002

## Comments

The shell programming language would not be complete without a *comment* statement. A comment is a way for you to insert remarks or comments inside the program that otherwise have no effect on its execution.

Whenever the shell encounters the special character `#` at the start of a word, it takes whatever characters follow the `#` to the end of the line as comments and simply ignores them. [\[2\]](#) If the `#` starts the line, the entire line is treated as a comment by the shell. Here are examples of valid comments:

*[2] Note that the `#` may be your default erase character. If so, to enter the character into an editor such as `ed` or `vi`, you'll have to "escape" it by preceding it with a `\`. Alternatively, you can change your erase character to something else with the `stty` command.*

```
# Here is an entire commentary line

who | wc -l          # count the number of users

#

# Test to see if the correct arguments were supplied

#
```

Comments are useful for documenting commands or sequences of commands whose purposes may not be obvious or are sufficiently complex so that if you were to look at the program again in a week you might forget why they're there or what they do. Judicious use of comments can help make shell programs easier to debug and to maintain—both by you and by someone else who may have to support your programs.

Let's go back to the `stats` program and insert some comments:

```
$ cat stats

#

# stats -- prints: date, number of users logged on,
```

```
#           and current working directory
```

```
#
```

```
echo The current date and time is:
```

```
date
```

```
echo
```

```
echo The number of users on the system is:
```

```
who | wc -l
```

```
echo
```

```
echo Your current working directory is:
```

```
pwd
```

```
$
```

The extra blank lines cost little in terms of program space yet add much in terms of program readability. They're simply ignored by the shell.

# Variables

Like virtually all programming languages, the shell allows you to store values into *variables*. A shell variable begins with an alphabetic or underscore (`_`) character and is followed by zero or more alphanumeric or underscore characters.

To store a value inside a shell variable, you simply write the name of the variable, followed immediately by the equals sign `=`, followed immediately by the value you want to store in the variable:

```
variable=value
```

For example, to assign the value 1 to the shell variable `count`, you simply write

```
count=1
```

and to assign the value `/users/steve/bin` to the shell variable `my_bin`, you simply write

```
my_bin=/users/steve/bin
```

A few important points here. First, spaces are not permitted on either side of the equals sign. Keep that in mind, especially if you're in the good programming habit of inserting spaces around operators. In the shell language, you can't put those spaces in.

Second, unlike most other programming languages, the shell has no concept whatsoever of *data types*. Whenever you assign a value to a shell variable, no matter what it is, the shell simply interprets that value as a string of characters. So when you assigned 1 to the variable `count` previously, the shell simply stored the *character* 1 inside the variable `count`, making no observation whatsoever that an integer value was being stored in the variable.

If you're used to programming in a language such as C or Pascal, where all variables must be *declared*, you're in for another readjustment. Because the shell has no concept of data types, variables are not declared before they're used; they're simply assigned values when you want to use them.

As you'll see later in this chapter, the shell does support integer operations on shell variables that contain strings that are also valid numbers through special built-in operations.

Because the shell is an interpretive language, you can assign values to variables directly at your terminal:

```
$ count=1                Assign character 1 to count
$ my_bin=/users/steve/bin  Assign /users/steve/bin to my_bin
$
```

So now that you know how to assign values to variables, what good is it? Glad you asked.

## Displaying the Values of Variables

The `echo` command is used to display the value stored inside a shell variable. To do this, you simply write

```
echo $variable
```

The `$` character is a special character to the shell. If a valid variable name follows the `$`, the shell takes this as an indication that the value stored inside that variable is to be substituted at that point. So, when you type

```
echo $count
```

the shell replaces `$count` with the value stored there; then it executes the `echo` command:

```
$ echo $count
1
$
```

Remember, the shell performs variable substitution *before* it executes the command (see [Figure 5.1](#)).

Figure 5.1. `echo $count`.

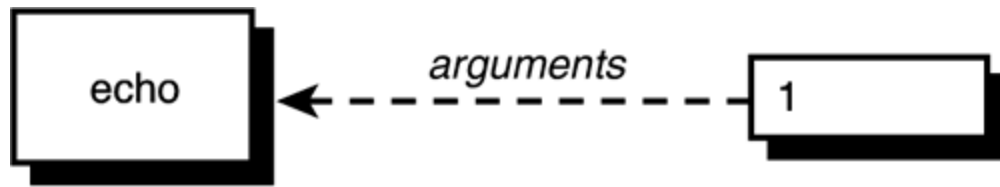

You can have the value of more than one variable substituted at a time:

```
$ echo $my_bin
/users/steve/bin
$ echo $my_bin $count
/users/steve/bin 1
$
```

In the second example, the shell substitutes the value of `my_bin` and `count` and then executes the `echo` command (see [Figure 5.2](#)).

Figure 5.2. —`echo $my_bin $count`.

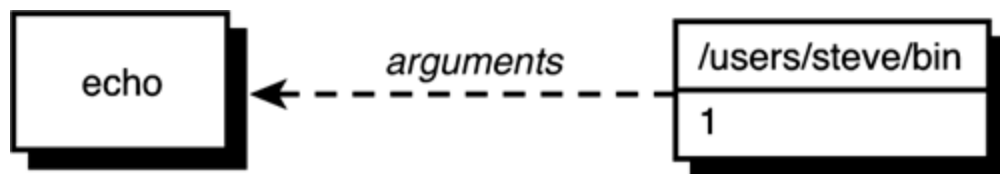

The values of variables can be used anywhere on the command line, as the next examples illustrate:

```
$ ls $my_bin
mon
nu
testx
$ pwd           Where are we?
/users/steve/documents/memos
```

```
$ cd $my_bin           Change to my bin directory
```

```
$ pwd
```

```
/users/steve/bin
```

```
$ number=99
```

```
$ echo There are $number bottles of beer on the wall
```

```
There are 99 bottles of beer on the wall
```

```
$
```

Here are some more examples:

```
$ command=sort
```

```
$ $command names
```

```
Charlie
```

```
Emanuel
```

```
Fred
```

```
Lucy
```

```
Ralph
```

```
Tony
```

```
Tony
```

```
$ command=wc
```

```
$ option=-l
```

```
$ file=names
```

```
$ $command $option $file
```

```
7 names
```

```
$
```

So you see, even the name of a command can be stored inside a variable. Because the shell performs its substitution before determining the name of the program to execute and its arguments, it scans the line

```
$command $option $file
```

and turns it into

```
wc -l names
```

Then it executes `wc`, passing the two arguments `-l` and `names`.

Variables can even be assigned to other variables, as shown in the next example:

```
$ value1=10
```

```
$ value2=value1
```

```
$ echo $value2
```

```
value1
```

*Didn't do that right*

```
$ value2=$value1
```

```
$ echo $value2
```

```
10
```

*That's better*

```
$
```

Remember that a dollar sign must always be placed before the variable name whenever you want to use the value stored in that variable.

## The Null Value

What do you think happens when you try to display the value of a variable that has no value assigned to it? Try it and see:



```
$ echo $nosuch          Never assigned it a value
```

```
$
```

You don't get an error message. Did the `echo` command display anything at all? Let's see whether we can more precisely determine that:

```
$ echo :$nosuch:       Surround its value with colons
```

```
::
```

```
$
```

So you see `no` characters were substituted by the shell for the value of `nosuch`.

A variable that contains no value is said to contain the *null* value. It is the default case for variables that you never store values in. When the shell performs its variable substitution, any values that are null are *completely* removed from the command line, without a trace:

```
$ wc $nosuch -l $nosuch $nosuch names
```

```
7 names
```

```
$
```

The shell scans the command line substituting the null value for the variable `nosuch`. After the scan is completed, the line effectively looks like this:

```
wc -l names
```

which explains why it works.

Sometimes you may want to explicitly set a variable null in a program. This can be done by simply assigning no value to the variable, as in

```
dataflag=
```

Alternatively, you can list two adjacent pairs of quotes after the `=`. So

```
dataflag=" "
```

and

```
dataflag=''
```

both have the same effect of assigning the null value to `dataflag`. Be advised that the assignment

```
dataflag=" "
```

is *not* equivalent to the three previous ones because it assigns a single space character to `dataflag`; that's different from assigning *no* characters to it.

## Filename Substitution and Variables

Here's a puzzle for you: If you type

```
x=*
```

will the shell store the character `*` into the variable `x`, or will it store the names of all the files in your current directory into the variable `x`? Let's try it out and see:

```
$ ls What files do we have?
```

```
addresses
```

```
intro
```

```
lotsaspaces
```

```
names
```

```
nu
```

```
numbers
```

```
phonebook
```

```
stat
```

```
$ x=*
```

```
$ echo $x
```

```
addresses intro lotsaspaces names nu numbers phonebook stat
```

```
$
```

There's a lot to be learned from this small example. Was the list of files stored into the variable `x` when

```
x=*
```

was executed, or did the shell do the substitution when

```
echo $x
```

was executed?

The answer is that the shell does not perform filename substitution when assigning values to variables. Therefore,

```
x=*
```

assigns the single character `*` to `x`. This means that the shell did the filename substitution when executing the `echo` command. In fact, the precise sequence of steps that occurred when

echo \$x

was executed is as follows:

1. The shell scanned the line, substituting `*` as the value of `x`.
2. The shell rescanned the line, encountered the `*`, and then substituted the names of all files in the current directory.
3. The shell initiated execution of `echo`, passing it the file list as arguments (see [Figure 5.3](#)).

Figure 5.3. `echo $x`.

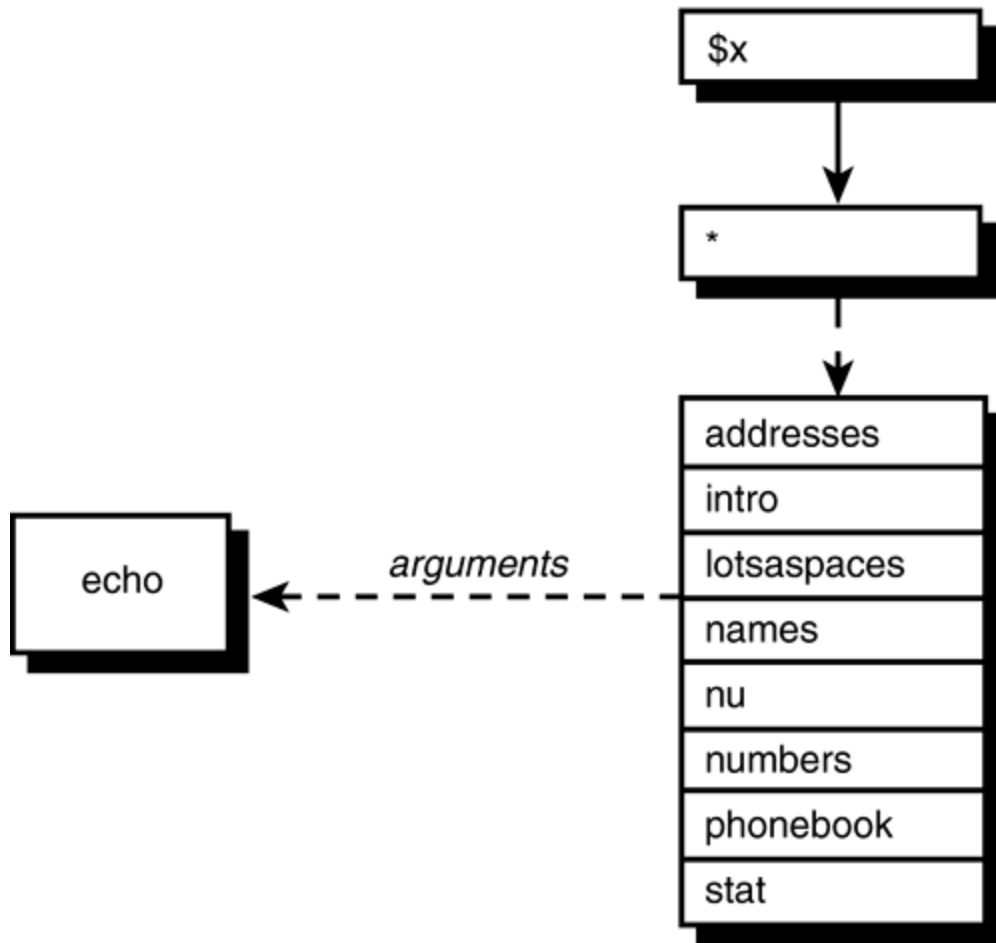

This order of evaluation is important. Remember, first the shell does variable substitution, then does filename substitution, and then parses the line into arguments.

## The `${variable}` Construct

Suppose that you have the name of a file stored in the variable `filename`. If you wanted to rename that file so that the new name was the same as the old, except with an `x` added to the end, your first impulse would be to type

```
mv $filename $filenameX
```

When the shell scans this command line, it substitutes the value of the variable `filename` *and also the value of the variable* `filenameX`. The shell thinks `filenameX` is the full name of the variable because it's composed entirely of valid variable name characters. To avoid this problem, you can delimit the end of the variable name by enclosing the entire name (but not the leading dollar sign) in a pair of curly braces, as in

```
${filename}X
```

This removes the ambiguity, and the `mv` command then works as desired:

```
mv $filename ${filename}X
```

Remember that the braces are necessary only if the last character of the variable name is followed by an alphanumeric character or an underscore.

## Built-in Integer Arithmetic

The POSIX standard shell provides a mechanism for performing integer arithmetic on shell variables called *arithmetic expansion*. Note that some older shells do not support this feature.

The format for arithmetic expansion is

```
$(expression)
```

where *expression* is an arithmetic expression using shell variables and operators. Valid shell variables are those that contain numeric values (leading and trailing whitespace is allowed). Valid operators are taken from the C programming language and are listed in Appendix A, "Shell Summary."

The result of computing *expression* is substituted on the command line. For example,

```
echo $(i+1)
```

adds one to the value in the shell variable `i` and prints the result. Notice that the variable `i` doesn't have to be preceded by a dollar sign. That's because the shell knows that the only valid items that can appear in arithmetic expansions are operators, numbers, and variables. If the variable is not defined or contains a NULL string, its value is assumed to be zero. So if we have not assigned any value yet to the variable `a`, we can still use it in an integer expression:

```
$ echo $a           Variable a not set
```

```
$
```

```
$ echo $(a = a + 1)   Equivalent to a = 0 + 1
```

```
1
```

```
$ echo $a
```

```
1
```

*Now a contains 1*

```
$
```

Note that assignment is a valid operator, and the value of the assignment is substituted in the second `echo` command in the preceding example.

Parentheses may be used freely inside expressions to force grouping, as in

```
echo $((i = (i + 10) * j))
```

If you want to perform an assignment without `echo` or some other command, you can move the assignment *before* the arithmetic expansion.

So to multiply the variable `i` by 5 and assign the result back to `i` you can write

```
i=$(( i * 5 ))
```

Note that spaces are optional inside the double parentheses, but are not allowed when the assignment is outside them.

Finally, to test to see whether `i` is greater than or equal to 0 and less than or equal to 100, you can write

```
result=$(( i >= 0 && i <= 100 ))
```

which assigns `result` 1 if the expression is true and 0 if it's false:

```
$ i=$(( 100 * 200 / 10 ))
```

```
$ j=$(( i < 1000 ))           If i is < 1000, set j = 0; otherwise 1
```

```
$ echo $i $j
```

```
2000 0                        i is 2000, so j was set
```

```
$
```

That concludes our introduction to writing commands and using variables. The next chapter goes into detail on the quoting mechanisms in the shell.

**Team LiB**

**← PREVIOUS**

**NEXT →**



## Exercises

1: Which of the following are valid variable names?

XxXxXx	—
12345	HOMEDIR
file.name	_date
file_name	x0-9
file1	Slimit

2: Suppose that your HOME directory is `/users/steve` and that you have subdirectories as shown in the following figure:

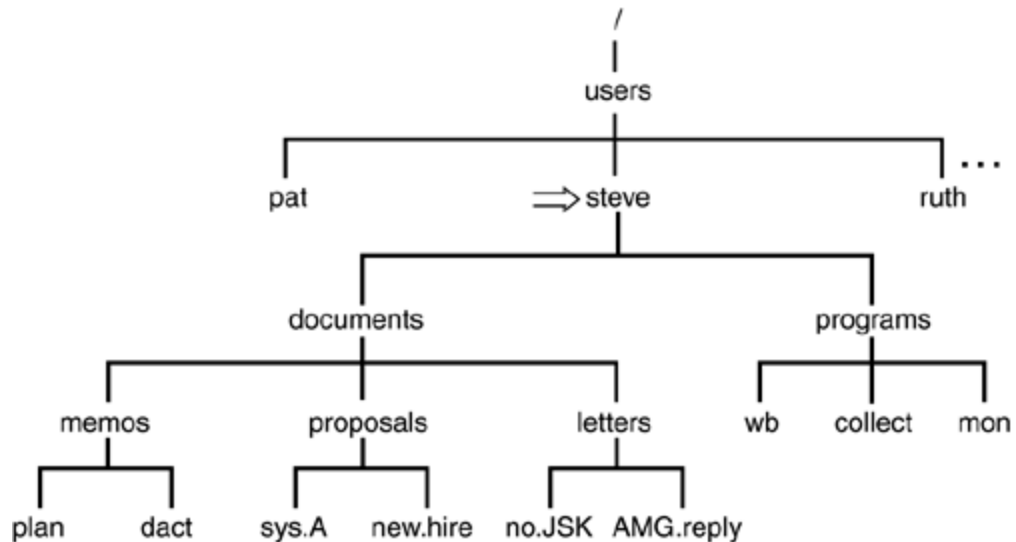

Assuming that you just logged in to the system and executed the following commands:

```
$ docs=/users/steve/documents
```

```
$ let=$docs/letters
```

```
$ prop=$docs/proposals
```

```
$
```

write the commands in terms of these variables to

- a. List the contents of the `documents` directory.
- b. Copy all files from the `letters` directory to the `proposals` directory.
- c. Move all files whose names contain a capital letter from the `letters` directory to the current directory.
- d. Count the number of files in the `memos` directory.

What would be the effect of the following commands?

- a. `ls $let/..`
  - b. `cat $prop/sys.A >> $let/no.JSK`
  - c. `echo $let/*`
  - d. `cp $let/no.JSK $progs`
  - e. `cd $prop`
- 3: Write a program called `nf` to display the number of files in your current directory. Type in the program and test it out.
- 4: Write a program called `whos` to display a sorted list of the logged-in users. Just display the usernames and no other information. Type in the program and test it out.

# Chapter 6. Can I Quote You on That?

## IN THIS CHAPTER

- [The Single Quote](#)
- [The Double Quote](#)
- [The Backslash](#)
- [Command Substitution](#)
- [Exercises](#)

This chapter teaches you about a unique feature of the shell programming language: the way it interprets quote characters. Basically, the shell recognizes four different types of quote characters:

- The single quote character `'`
- The double quote character `"`
- The backslash character `\`
- The back quote character ```

The first two and the last characters in the preceding list must occur in pairs, whereas the backslash character is unary in nature. Each of these quotes has a distinct meaning to the shell. We'll cover them in separate sections of this chapter.

## The Single Quote

There are several reasons that you might need to use quotes in the shell. One of these is to keep characters otherwise separated by whitespace characters together. Let's look at an example. Here's a file called `phonebook` that contains names and phone numbers:

```
$ cat phonebook
Alice Chebba    973-555-2015
Barbara Swingle 201-555-9257
Liz Stachiw    212-555-2298
Susan Goldberg  201-555-7776
Susan Topple   212-555-4932
Tony Iannino   973-555-1295
$
```

To look up someone in our `phonebook` file—which has been kept small here for the sake of example—you use `grep`:

```
$ grep Alice phonebook
Alice Chebba    973-555-2015
$
```

Look what happens when you look up `Susan`:

```
$ grep Susan phonebook
Susan Goldberg  201-555-7776
Susan Topple   212-555-4932
```

```
$
```

There are two lines that contain `Susan`, thus explaining the two lines of output. One way to overcome this problem would be to further qualify the name. For example, you could specify the last name as well:

```
$ grep Susan Goldberg phonebook
```

```
grep: can't open Goldberg
```

```
Susan Goldberg 201-555-7776
```

```
Susan Topple 212-555-4932
```

```
$
```

Recalling that the shell uses one or more whitespace characters to separate the arguments on the line, the preceding command line results in `grep` being passed three arguments: `Susan`, `Goldberg`, and `phonebook` (see [Figure 6.1](#)).

Figure 6.1. `grep Susan Goldberg phonebook`.

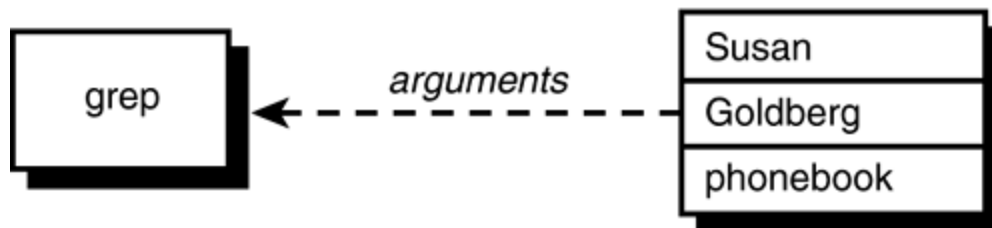

When `grep` is executed, it takes the first argument as the pattern and the remaining arguments as the names of the files to search for the pattern. In this case, `grep` thinks it's supposed to look for `Susan` in the files `Goldberg` and `phonebook`. So it tries to open the file `Goldberg`, can't find it, and issues the error message:

```
grep: can't open Goldberg
```

Then it goes to the next file, `phonebook`, opens it, searches for the pattern `Susan`, and prints the two matching lines. The problem boils down to trying to pass whitespace characters as arguments to programs. This can be done by enclosing the entire argument inside a pair of single quotes, as in

```
grep 'Susan Goldberg' phonebook
```

When the shell sees the first single quote, *it ignores any otherwise special characters that follow until it sees the closing quote.*

```
$ grep 'Susan Goldberg' phonebook
```

```
Susan Goldberg    201-555-7776
```

```
$
```

In this case, the shell encountered the first `'`, and ignored any special characters until it found the closing `'`. So the space between `Susan` and `Goldberg`, which would have normally delimited the two arguments, was ignored by the shell. The shell therefore divided the command line into *two* arguments, the first `Susan Goldberg` (which includes the space character) and the second `phonebook`. It then executed `grep`, passing it these two arguments (see [Figure 6.2](#)).

Figure 6.2. `grep 'Susan Goldberg' phonebook`.

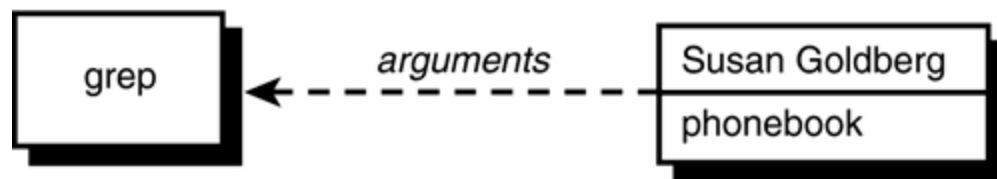

`grep` then took the first argument, `Susan Goldberg`, and looked for it in the file specified by the second argument, `phonebook`. Note that the shell *removes* the quotes from the command line and does not pass them to the program.

No matter how many space characters are enclosed between quotes, they are preserved by the shell.

```
$ echo one           two       three    four
```

```
one two three four
```

```
$ echo 'one         two       three    four'
```

```
one           two       three    four
```

```
$
```

In the first case, the shell removes the extra whitespace characters from the line and passes `echo` the four arguments `one`, `two`, `three`, and `four` (see [Figure 6.3](#)).

Figure 6.3. `echo one two three four`.

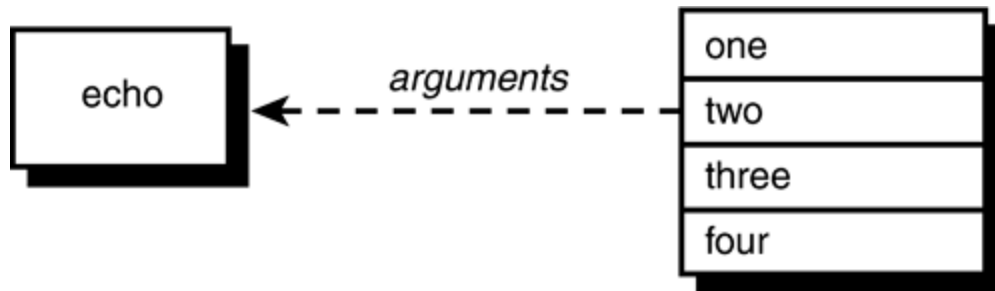

In the second case, the space characters are preserved, and the shell treats the entire string of characters enclosed between the quotes as a single argument when executing `echo` (see [Figure 6.4](#)).

Figure 6.4. `echo 'one two three four'`.

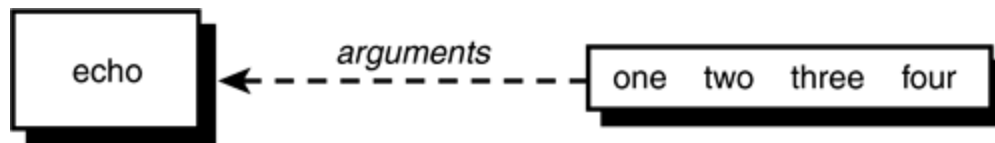

As we mentioned, all special characters are ignored by the shell if they appear inside single quotes. That explains the output from the following:

```
$ file=/users/steve/bin/progl
$ echo $file
/users/steve/bin/progl
$ echo '$file'      $ not interpreted
$file
$ echo *
addresses intro lotsaspaces names nu numbers phonebook stat
$ echo '*'
*
$ echo '< > | ; ( ) { } >> " ` &'
< > | ; ( ) { } >> " ` &
```

```
$
```

Even the Enter key will be ignored by the shell if it's enclosed in quotes:

```
$ echo 'How are you today,
```

```
> John'
```

```
How are you today,
```

```
John
```

```
$
```

After typing the first line, the shell sees that the quote isn't matched, so it waits for you to type in the closing quote. As an indication that the shell is waiting for you to finish typing in a command, it changes your prompt character from `$` to `>`. This is known as your *secondary* prompt character and is displayed by the shell whenever it's waiting for you to finish typing a command.

Quotes are also needed when assigning values containing whitespace or special characters to shell variables:

```
$ message='I must say, this sure is fun'
```

```
$ echo $message
```

```
I must say, this sure is fun
```

```
$ text='* means all files in the directory'
```

```
$ echo $text
```

```
names nu numbers phonebook stat means all files in the directory
```

```
$
```

The quotes are needed in the assignments made to the variables `message` and `text` because of the embedded spaces. In the preceding example, you are reminded that the shell still does filename substitution after variable name substitution, meaning that the `*` is replaced by the names of all the files in the current directory before the `echo` is executed. There is a way to overcome this annoyance, and it's through the use of double quotes.





## The Double Quote

Double quotes work similarly to single quotes, except that they're not as restrictive. Whereas the single quotes tell the shell to ignore *all* enclosed characters, double quotes say to ignore *most*. In particular, the following three characters are not ignored inside double quotes:

- Dollar signs
- Back quotes
- Backslashes

The fact that dollar signs are not ignored means that variable name substitution is done by the shell inside double quotes.

```
$ x=*
$ echo $x
addresses intro lotsaspaces names nu numbers phonebook stat
$ echo '$x'
$x
$ echo "$x"
*
```

Here you see the major differences between no quotes, single quotes, and double quotes. In the first case, the shell sees the asterisk and substitutes all the filenames from the current directory. In the second case, the shell leaves the characters enclosed within the single quotes alone, which results in the display of `$x`. In the final case, the double quotes indicate to the shell that variable name substitution is still to be performed inside the quotes. So the shell substitutes `*` for `$x`. Because filename substitution is *not* done inside double quotes, `*` is then passed to `echo` as the value to be displayed.

So if you want to have the value of a variable substituted, but don't want the shell to treat the substituted characters specially, you must enclose the variable inside double quotes.

Here's another example illustrating the difference between double quotes and no quotes:

```
$ address="39 East 12th Street
> New York, N. Y. 10003"
$ echo $address
39 East 12th Street New York, N. Y. 10003
$ echo "$address"
39 East 12th Street
New York, N. Y. 10003
$
```

It makes no difference whether the value assigned to `address` is enclosed in single quotes or double quotes. The shell displays the secondary command prompt in either case to tell you it's waiting for the corresponding closed quote.

After assigning the two-line address to `address`, the value of the variable is displayed by `echo`. Notice that the address is displayed on a single line. The reason is the same as what caused

```
echo one           two       three   four
```

to be displayed as

```
one two three four
```

Recalling that the shell removes spaces, tabs, and newlines (that is, whitespace characters) from the command line and then cuts it up into arguments, in the case of

```
echo $address
```

the shell simply removes the embedded newline character, treating it as it would a space or tab: as an argument delimiter. Then it passes the *nine* arguments to `echo` to be displayed. `echo` never gets a chance to see that newline; the shell gets to it first (see [Figure 6.5](#)).

Figure 6.5. `echo $address`.

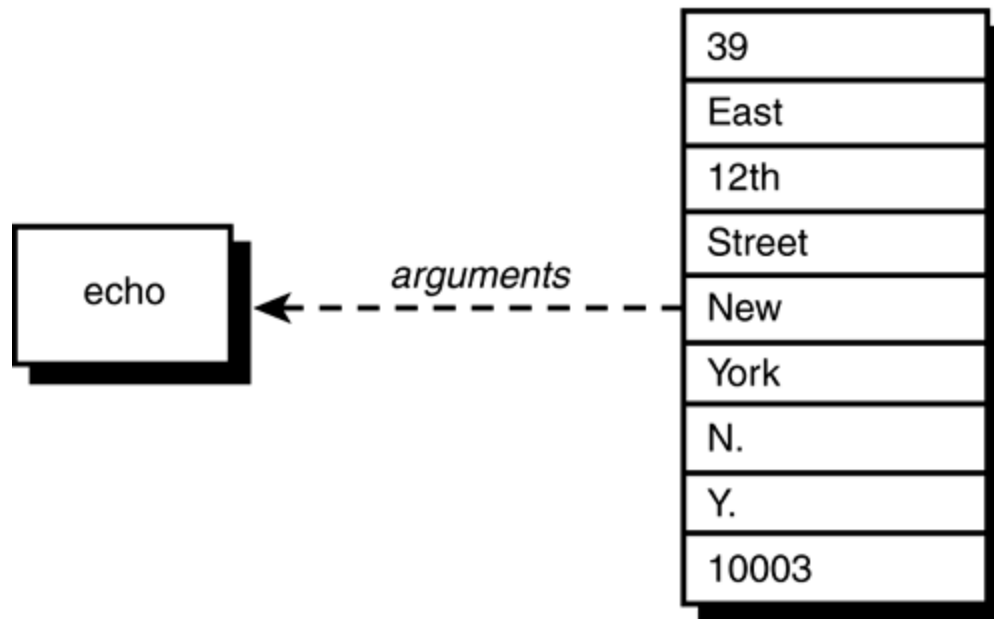

When the command

```
echo "$address"
```

is used instead, the shell substitutes the value of `address` as before, except that the double quotes tell it to leave any embedded whitespace characters alone. So in this case, the shell passes a single argument to `echo`—an argument that contains an embedded newline. `echo` simply displays its single argument at the terminal; [Figure 6.6](#) illustrates this. The newline character is depicted by the characters `\n`.

Figure 6.6. `echo "$address"`.

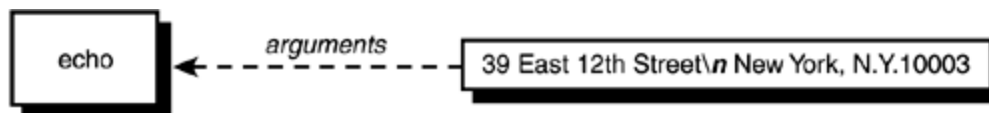

Double quotes can be used to hide single quotes from the shell, and vice versa:

```
$ x="' Hello,' he said"
```

```
$ echo $x
```

'Hello,' he said

```
$ article=' "Keeping the Logins from Lagging," Bell Labs Record'
```

```
$ echo $article
```

```
"Keeping the Logins from Lagging," Bell Labs Record
```

```
$
```

[Team LiB](#)

[◀ PREVIOUS](#)

[NEXT ▶](#)

## The Backslash

Basically, the backslash is equivalent to placing single quotes around a single character, with a few minor exceptions. The backslash quotes the single character that immediately follows it. The general format is

```
\c
```

where *c* is the character you want to quote. Any special meaning normally attached to that character is removed. Here is an example:

```
$ echo >
syntax error: 'newline or ;' unexpected
$ echo \>
>
$
```

In the first case, the shell sees the `>` and thinks that you want to redirect `echo`'s output to a file. So it expects a filename to follow. Because it doesn't, the shell issues the error message. In the next case, the backslash removes the special meaning of the `>`, so it is passed along to `echo` to be displayed.

```
$ x=*
$ echo \$x
$x
$
```

In this case, the shell ignores the `$` that follows the backslash, and as a result, variable substitution is not performed.

Because a backslash removes the special meaning of the character that follows, can you guess what

happens if that character is another backslash? Right, it removes the special meaning of the backslash:

```
$ echo \\
\  
$
```

Naturally, you could have also written

```
$ echo '\'  
\  
$
```

## Using the Backslash for Continuing Lines

As mentioned at the start of this section, `\c` is basically equivalent to `'c'`. One exception to this rule is when the backslash is used as the very last character on the line:

```
$ lines=one'  
> 'two           Single quotes tell shell to ignore newline  
$ echo "$lines"  
one  
two  
$ lines=one\  
           Try it with a \ instead  
> two  
$ echo "$lines"  
onetwo  
$
```

The shell treats a backslash at the end of the line as a line continuation. It *removes* the newline character that follows and also does not treat the newline as an argument delimiter (it's as if it wasn't even typed). This construct is most often used for typing long commands over multiple lines.

## The Backslash Inside Double Quotes

We noted earlier that the backslash is one of the three characters interpreted by the shell inside double quotes. This means that you can use the backslash inside these quotes to remove the meaning of characters that otherwise *would* be interpreted inside double quotes (that is, other backslashes, dollar signs, back quotes, newlines, and other double quotes). If the backslash precedes any other character inside double quotes, the backslash is ignored by the shell and passed on to the program:

```
$ echo "\$x"
$x

$ echo "\ is the backslash character"
\ is the backslash character

$ x=5

$ echo "The value of x is \"$x\""
```

The value of x is "5"

```
$
```

In the first example, the backslash precedes the dollar sign, interpreted by the shell inside double quotes. So the shell ignores the dollar sign, removes the backslash, and executes `echo`. In the second example, the backslash precedes a space, *not* interpreted by the shell inside double quotes. So the shell ignores the backslash and passes it on to the `echo` command. The last example shows the backslash used to enclose double quotes inside a double-quoted string.

As an exercise in the use of quotes, let's say that you want to display the following line at the terminal:

```
<<< echo $x >>> displays the value of x, which is $x
```

The intention here is to substitute the value of `x` in the second instance of `$x`, but not in the first.



Let's first assign a value to `x`:

```
$ x=1
```

```
$
```

Now try displaying the line without using any quotes:

```
$ echo <<< echo $x >>> displays the value of x, which is $x
```

```
syntax error: '<' unexpected
```

```
$
```

The `<` signals input redirection to the shell; this is the reason for the error message.

If you put the entire message inside single quotes, the value of `x` won't be substituted at the end. If you enclose the entire string in double quotes, both occurrences of `$x` will be substituted. Here are two different ways to do the quoting properly (realize that there are usually several different ways to quote a string of characters to get the results you want):

```
$ echo "<<< echo \ $x >>> displays the value of x, which is $x"
```

```
<<< echo $x >>> displays the value of x, which is 1
```

```
$ echo '<<< echo $x >>> displays the value of x, which is' $x
```

```
<<< echo $x >>> displays the value of x, which is 1
```

```
$
```

In the first case, everything is enclosed in double quotes, and the backslash is used to prevent the shell from performing variable substitution in the first instance of `$x`. In the second case, everything up to the last `$x` is enclosed in single quotes. If the variable `x` might have contained some filename substitution or whitespace characters, a safer way of writing the `echo` would have been

```
echo '<<< echo $x >>> displays the value of x, which is' "$x"
```



# Command Substitution

*Command substitution* refers to the shell's capability to insert the standard output of a command at any point in a command line. There are two ways in the shell to perform command substitution: by enclosing a shell command with back quotes and with the `$(...)` construct.

## The Back Quote

The back quote is unlike any of the previously encountered types of quotes. Its purpose is not to protect characters from the shell but to tell the shell to execute the enclosed command and to insert the standard output from the command at that point on the command line. The general format for using back quotes is

```
`command`
```

where *command* is the name of the command to be executed and whose output is to be inserted at that point.<sup>[1]</sup>

<sup>[1]</sup> Note that using the back quote for command substitution is no longer the preferred method; however, we cover it here because of the large number of older, canned shell programs that still use this construct. Also, you should know about back quotes in case you ever need to write shell programs that are portable to older Unix systems with shells that don't support the newer `$(...)` construct.

Here is an example:

```
$ echo The date and time is: `date`
```

```
The date and time is: Wed Aug 28 14:28:43 EDT 2002
```

```
$
```

When the shell does its initial scan of the command line, it notices the back quote and expects the name of a command to follow. In this case, the shell finds that the `date` command is to be executed. So it executes `date` and replaces the ``date`` on the command line with the output from the `date`. After that, it divides the command line into arguments in the normal manner and then initiates execution of the `echo` command.

```
$ echo Your current working directory is `pwd`
```

```
Your current working directory is /users/steve/shell/ch6
```

```
$
```

Here the shell executes `pwd`, inserts its output on the command line, and then executes the `echo`. Note that in the following section, back quotes can be used in all the places where the `$(...)` construct is used.

## The `$(...)` Construct

The POSIX standard shell supports the newer `$(...)` construct for command substitution. The general format is

```
$(command)
```

where, as in the back quoting method, *command* is the name of the command whose standard output is to be substituted on the command line. For example:

```
$ echo The date and time is: $(date)
```

```
The date and time is: Wed Aug 28 14:28:43 EDT 2002
```

```
$
```

This construct is better than back quotes for a couple of reasons. First, complex commands that use combinations of forward and back quotes can be difficult to read, particularly if the typeface you're using doesn't have visually different single quotes and back quotes; second, `$(...)` constructs can be easily nested, allowing command substitution *within* command substitution. Although nesting can also be performed with back quotes, it's a little trickier. You'll see an example of nested command substitution later in this section.

You are not restricted to executing a single command between the parentheses: Several commands can be executed if separated by semicolons. Also, pipelines can be used. Here's a modified version of the `nu` program that displays the number of logged-in users:

```
$ cat nu
```

```
echo There are $(who | wc -l) users logged in
```

```
$ nu Execute it
```

```
There are 13 users logged in
```

```
$
```

Because single quotes protect everything, the following output should be clear:

```
$ echo '$(who | wc -l) tells how many users are logged in'
```

```
$(who | wc -l) tells how many users are logged in
```

```
$
```

But command substitution `/s` interpreted inside double quotes:

```
$ echo "You have $(ls | wc -l) files in your directory"
```

```
You have      7 files in your directory
```

```
$
```

(What causes those leading spaces before the `7`?) Remember that the shell is responsible for executing the command enclosed between the parentheses. The only thing the `echo` command sees is the output that has been inserted by the shell.

Suppose that you're writing a shell program and want to assign the current date and time to a variable called `now`, perhaps to display it later at the top of a report, or log it into a file. The problem here is that you somehow want to take the output from `date` and assign it to the variable. Command substitution can be used for this:

```
$ now=$(date)           Execute date and store the output in now
```

```
$ echo $now            See what got assigned
```

```
Wed Aug 28 14:47:26 EDT 2002
```

```
$
```

When you write

```
now=$(date)
```

the shell realizes that the entire output from `date` is to be assigned to `now`. Therefore, you don't need to enclose `$(date)` inside double quotes.

Even commands that produce more than a single line of output can be stored inside a variable:

```
$ filelist=$(ls)
```

```
$ echo $filelist
```

```
addresses intro lotsaspaces names nu numbers phonebook stat
```

```
$
```

What happened here? You end up with a horizontal listing of the files even though the newlines from `ls` were stored inside the `filelist` variable (take our word for it). The newlines got eaten up when the value of `filelist` was substituted by the shell in processing the `echo` command line. Double quotes around the variable will preserve the newlines:

```
$ echo "$filelist"
```

```
addresses
```

```
intro
```

```
lotsaspaces
```

```
names
```

```
nu
```

```
numbers
```

```
phonebook
```

```
stat
```

```
$
```

To store the contents of a file into a variable, you can use `cat`:

```
$ namelist=$(cat names)
```

```
$ echo "$names"
```

```
Charlie
```

```
Emanuel
```

```
Fred
```

```
Lucy
```

```
Ralph
```

```
Tony
```

```
Tony
```

```
$
```

If you want to mail the contents of the file `memo` to all the people listed in the `names` file (who we'll assume here are users on your system), you can do the following:

```
$ mail $(cat names) < memo
```

```
$
```

Here the shell executes the `cat` and inserts the output on the command line so it looks like this:

```
mail Charlie Emanuel Fred Lucy Ralph Tony Tony < memo
```

Then it executes `mail`, redirecting its standard input from the file `memo` and passing it the names of seven users who are to receive the mail.

Notice that `Tony` receives the same mail twice because he's listed twice in the `names` file. You can remove any duplicate entries from the file by using `sort` with the `-u` option (remove duplicate lines) rather than `cat` to ensure that each person only receives mail once:

```
$ mail $(sort -u names) < memo
```

```
$
```

It's worth noting that the shell does filename substitution *after* it substitutes the output from commands. Enclosing the commands inside double quotes prevents the shell from doing the filename substitution on this output if desired.

Command substitution is often used to change the value stored in a shell variable. For example, if the shell variable `name` contains someone's name, and you want to convert every character in that variable to uppercase, you could use `echo` to get the variable to `tr`'s input, perform the translation, and then assign the result back to the variable:

```
$ name="Ralph Kramden"

$ name=$(echo $name | tr '[a-z]' '[A-Z]') Translate to uppercase

$ echo $name

RALPH KRAMDEN

$
```

The technique of using `echo` in a pipeline to write data to the standard input of the following command is a simple yet powerful technique; it's used often in shell programs.

The next example shows how `cut` is used to extract the first character from the value stored in a variable called `filename`:

```
$ filename=/users/steve/memos

$ firstchar=$(echo $filename | cut -c1)

$ echo $firstchar

/

$
```

`sed` is also often used to "edit" the value stored in a variable. Here it is used to extract the last character from the variable `file`:

```
$ file=exec.o
```



```
$ lastchar=$(echo $file | sed 's/.*\(.\)$/\1/')
$ echo $lastchar
o
$
```

The `sed` command says to replace all the characters on the line with the last one. The result of the `sed` is stored in the variable `lastchar`. The single quotes around the `sed` command are important because they prevent the shell from messing around with the backslashes (would double quotes also have worked?).

Finally, command substitutions can be nested. Suppose that you want to change every occurrence of the first character in a variable to something else. In a previous example, `firstchar=$(echo $filename | cut -c1)` gets the first character from `filename`, but how do we use this character to change every occurrence in `filename`? A two-step process is one way:

```
$ filename=/users/steve/memos
$ firstchar=$(echo $filename | cut -c1)
$ filename=$(echo $filename | tr "$firstchar" "^")    translate / to ^
$ echo $filename
^users^steve^memos
$
```

Or a single, nested command substitution can perform the same operation:

```
$ filename=/users/steve/memos
$ filename=$(echo $filename | tr "$(echo $filename | cut -c1)" "^")
$ echo $filename
^users^steve^memos
$
```

If you have trouble understanding this example, compare it to the previous one: Note how the `firstchar` variable in the earlier example is replaced by the nested command substitution; otherwise, the two examples are the same.

## The `expr` Command

Although the POSIX standard shell supports built-in integer arithmetic operations, older shells don't. It's likely that you may see command substitution with a Unix program called `expr`, which evaluates an expression given to it on the command line:

```
$ expr 1 + 2
```

```
3
```

```
$
```

Each operator and operand given to `expr` must be a separate argument, thus explaining the output from the following:

```
$ expr 1+2
```

```
1+2
```

```
$
```

The usual arithmetic operators are recognized by `expr`: `+` for addition, `-` for subtraction, `/` for division, `*` for multiplication, and `%` for modulus (remainder).

```
$ expr 10 + 20 / 2
```

```
20
```

```
$
```

Multiplication, division, and modulus have higher precedence than addition and subtraction. Thus, in the preceding example the division was performed before the addition.

```
$ expr 17 * 6
```

```
expr: syntax error
```

```
$
```

What happened here? The answer: The shell saw the `*` and substituted the names of all the files in your directory! It has to be quoted to keep it from the shell:

```
$ expr "17 * 6"
```

```
17 * 6
```

```
$
```

That's not the way to do it. Remember that `expr` must see each operator and operand as a separate argument; the preceding example sends the whole expression in as a single argument.

```
$ expr 17 \* 6
```

```
102
```

```
$
```

Naturally, one or more of the arguments to `expr` can be the value stored inside a shell variable because the shell takes care of the substitution first anyway:

```
$ i=1
```

```
$ expr $i + 1
```

```
2
```

```
$
```

This is the older method for performing arithmetic on shell variables. Do the same type of thing as shown previously only use the command substitution mechanism to assign the output from `expr` back to the variable:

```
$ i=1
$ i=$(expr $i + 1)      Add 1 to i
$ echo $i
2
$
```

In legacy shell programs, you're more likely to see `expr` used with back quotes:

```
$ i=`expr $i + 1`      Add 1 to i
$ echo $i
3
$
```

Note that like the shell's built-in integer arithmetic, `expr` only evaluates integer arithmetic expressions. You can use `awk` or `bc` if you need to do floating point calculations. Also note that `expr` has other operators. One of the most frequently used ones is the `:` operator, which is used to match characters in the first operand against a regular expression given as the second operand. By default, it returns the number of characters matched.

The `expr` command

```
expr "$file" : ".*"
```

returns the number of characters stored in the variable `file`, because the regular expression `.*` matches all the characters in the string. For more details on `expr`, consult your *Unix User's Manual*.

[Table A.5](#) in [Appendix A](#) summarizes the way quotes are handled by the shell.

# Exercises

1: Given the following assignments:

```
$ x=*
$ y=?
$ z='one
> two
> three'
$ now=$(date)
$ symbol='>'
$
```

and these files in your current directory:

```
$ echo *
names test1 u vv zebra
$
```

What will the output be from the following commands?

```
echo *** error ***           echo 'Is 5 * 4 > 18 ?'
```

```
echo $x                       echo What is your name?
```

```
echo $y                echo Would you like to play a game?
```

```
echo "$y"              echo \*\**
```

```
echo $z | wc -l        echo \$symbol
```

```
echo "$z" | wc -l      echo $symbol
```

```
echo '$z' | wc -l      echo "\"
```

```
echo _$now_           echo "\\
```

```
echo hello $symbol out echo \\
```

```
echo "\"              echo I don't understand
```

- 2: Write the commands to remove all the space characters stored in the shell variable `text`. Be sure to assign the result back to `text`. First use `tr` to do it and then do the same thing with `sed`.
- 3: Write the commands to count the number of characters stored in the shell variable `text`. Then write the commands to count all the alphabetic characters. (Hint: Use `sed` and `wc`.) What happens to special character sequences such as `\n` if they're stored inside `text`?
- 4: Write the commands to assign the unique lines in the file `names` to the shell variable `namelist`.

# Chapter 7. Passing Arguments

## IN THIS CHAPTER

- [The `shift` Command](#)
- [Exercises](#)

Shell programs become far more useful after you learn how to process arguments passed to them. In this chapter, you'll learn how to write shell programs that take arguments typed on the command line. Recall the program `run` that you wrote in [Chapter 5](#), "And Away We Go," to run the file `sys.caps` through `tbl`, `nroff`, and `lp`:

```
$ cat run

tbl sys.caps | nroff -mm -Tlp | lp

$
```

Suppose that you need to run other files besides `sys.caps` through this same command sequence. You could make a separate version of `run` for each such file; or, you could modify the `run` program so that you could specify the name of the file to be run on the command line. That is, you could change `run` so that you could type

```
run new.hire
```

for example, to specify that the file `new.hire` is to be run through this command sequence, or

```
run sys.caps
```

to specify the file `sys.caps`.

Whenever you execute a shell program, the shell automatically stores the first argument in the special shell variable `1`, the second argument in the variable `2`, and so on. These special variables—more formally known as *positional parameters*—are assigned after the shell has done its normal command-line processing (that is, I/O redirection, variable substitution, filename substitution,

and so on).

To modify the `run` program to accept the name of the file as an argument, all you do to the program is change the reference to the file `sys.caps` so that it instead references the first argument typed on the command line:

```
$ cat run
tbl $1 | nroff -mm -Tlp | lp

$ run new.hire           Execute it with new.hire as the argument

request id is laser1-24 (standard input)

$
```

Each time you execute the `run` program, whatever word follows on the command line will be stored inside the first positional parameter by the shell. In the example, `new.hire` will be stored in this parameter. Substitution of positional parameters is identical to substitution of other types of variables, so when the shell sees

```
tbl $1
```

it replaces the `$1` with the first argument supplied to the program: `new.hire`.

As another example, the following program, called `ison`, lets you know if a specified user is logged on:

```
$ cat ison
who | grep $1

$ who           See who's on

root      console Jul 7 08:37
barney    tty03     Jul 8 12:28
fred      tty04     Jul 8 13:40
joanne    tty07     Jul 8 09:35
tony      tty19     Jul 8 08:30
```



lulu tty23 Jul 8 09:55

\$ **ison tony**

tony tty19 Jul 8 08:30

\$ **ison pat**

\$ *Not logged on*

**Team LiB**

[◀ PREVIOUS](#)

[NEXT ▶](#)

## The \$# Variable

Whenever you execute a shell program, the special shell variable `$#` gets set to the number of arguments that were typed on the command line. As you'll see in the next chapter, this variable can be tested by the program to determine whether the correct number of arguments was typed by the user.

The next program called `args` was written just to get you more familiar with the way arguments are passed to shell programs. Study the output from each example and make sure that you understand it:

```
$ cat args                                Look at the program

echo $# arguments passed

echo arg 1 = :$1: arg 2 = :$2: arg 3 = :$3:

$ args a b c                               Execute it

3 arguments passed

arg 1 = :a: arg 2 = :b: arg 3 = :c:

$ args a b                                 Try it with two arguments

2 arguments passed

arg 1 = :a: arg 2 = :b: arg 3 = ::         Unassigned args are null

$ args                                     Try it with no arguments

0 arguments passed

arg 1 =:: arg 2 =:: arg 3 = ::

$ args "a b c"                             Try quotes

1 arguments passed

arg 1 = :a b c: arg 2 = :: arg 3 = ::

$ ls x*                                    See what files start with x

xact

xtra
```

```
$ args x* Try file name substitution
2 arguments passed
arg 1 = :xact: arg 2 = :xtra: arg 3 = ::

$ my_bin=/users/steve/bin
$ args $my_bin And variable substitution
1 arguments passed
arg 1 = :/users/steve/bin: arg 2 = :: arg 3 = ::

$ args $(cat names) Pass the contents of names
7 arguments passed
arg 1 = :Charlie: arg 2 = :Emanuel: arg3 = :Fred:

$
```

As you can see, the shell does its normal command-line processing even when it's executing your shell programs. This means that you can take advantage of the normal niceties such as filename substitution and variable substitution when specifying arguments to your programs.

## The `$*` Variable

The special variable `$*` references *all* the arguments passed to the program. This is often useful in programs that take an indeterminate or *variable* number of arguments. You'll see some more practical examples later. Here's a program that illustrates its use:

```
$ cat args2

echo $# arguments passed

echo they are :$*:

$ args2 a b c

3 arguments passed

they are :a b c:

$ args2 one           two

2 arguments passed

they are :one two:

$ args2

0 arguments passed

they are ::

$ args2 *

8 arguments passed

they are :args args2 names nu phonebook stat xact xtra:

$
```

## A Program to Look Up Someone in the Phone Book

Here's the `phonebook` file from previous examples:

```
$ cat phonebook
Alice Chebba      973-555-2015
Barbara Swingle  201-555-9257
Liz Stachiw       212-555-2298
Susan Goldberg    201-555-7776
Susan Topple      212-555-4932
Tony Iannino      973-555-1295
$
```

You know how to look up someone in the file by using `grep`:

```
$ grep Cheb phonebook
Alice Chebba      973-555-2015
$
```

And you know that if you want to look up someone by the full name, you'd better put quotes around it to keep the argument together:

```
$ grep "Susan T" phonebook
Susan Topple      212-555-4932
$
```

It would be nice to write a shell program that you could use to look up someone. Let's call the program `lu` and have it take as its argument the name of the person to look up:

```
$ cat lu
#
# Look someone up in the phone book
#
grep $1 phonebook
$
```

Here's a sample use of `lu`:

```
$ lu Alice
Alice Chebba    973-555-2015
$ lu Susan
Susan Goldberg  201-555-7776
Susan Topple    212-555-4932
$ lu "Susan T"
grep: can't open T
phonebook:Susan Goldberg  201-555-7776
phonebook:Susan Topple    212-555-4932
$
```

In the preceding example, you were careful to enclose `Susan T` in double quotes; so what happened? Look again at the `grep` executed in the `lu` program:

```
grep $1 phonebook
```

Even though enclosing `Susan T` inside double quotes results in its getting passed to `lu` as a single argument, when the shell substitutes this value for `$1` on `grep`'s command line, it then passes it as *two* arguments to `grep`. (Remember we had this same sort of discussion when we talked about variable substitution—first the shell substitutes the value of the variable; then it divides the line into arguments.)

You can alleviate this problem by enclosing `$1` inside double quotes (why not single?) in the `lu` program:

```
$ cat lu
#
# Look someone up in the phone book -- version 2
#
grep "$1" phonebook
$
```

Now let's try it again:

```
$ lu Tony
Tony Iannino    973-555-1295    This still works
$ lu "Susan T"
Susan Topple    212-555-4932
$
```

## A Program to Add Someone to the Phone Book

Let's continue with the development of programs that work with the `phonebook` file. You'll probably want to add someone to the file, particularly because our `phonebook` file is so small. You can write a program called `add` that takes two arguments: the name of the person to be added and the number. Then you can simply write the name and number, separated from each other by a tab character, onto the end of the `phonebook` file:

```
$ cat add
#
# Add someone to the phone book
#
echo "$1      $2" >> phonebook
$
```

Although you can't tell, there's a tab character that separates the `$1` from the `$2` in the preceding `echo` command. This tab must be quoted to make it to `echo` without getting gobbled up by the shell.

Let's try out the program:

```
$ add 'Stromboli Pizza' 973-555-9478
$ lu Pizza           See if we can find the new entry
Stromboli Pizza 973-555-9478   So far, so good
$ cat phonebook       See what happened
Alice Chebba      973-555-2015
Barbara Swingle  201-555-9257
Liz Stachiw       212-555-2298
Susan Goldberg    201-555-7776
```



```
Susan Topple      212-555-4932
Tony Iannino      973-555-1295
Stromboli Pizza  973-555-9478
$
```

`Stromboli Pizza` was quoted so that the shell passed it along to `add` as a single argument (what would have happened if it wasn't quoted?). After `add` finished executing, `lu` was run to see whether it could find the new entry, and it did. The `cat` command was executed to see what the modified `phonebook` file looked like. The new entry was added to the end, as intended. Unfortunately, the new file is no longer sorted. This won't affect the operation of the `lu` program, but you can add a `sort` to the `add` program to keep the file sorted after new entries are added:

```
$ cat add
#
# Add someone to the phonebook file -- version 2
#
echo "$1      $2" >> phonebook
sort -o phonebook phonebook
$
```

Recall that the `-o` option to `sort` specifies where the sorted output is to be written, and that this can be the same as the input file:

```
$ add 'Billy Bach' 201-555-7618
$ cat phonebook
Alice Chebba      973-555-2015
Barbara Swingle  201-555-9257
Billy Bach        201-555-7618
```

Liz Stachiw 212-555-2298

Stromboli Pizza 973-555-9478

Susan Goldberg 201-555-7776

Susan Topple 212-555-4932

Tony Iannino 973-555-1295

\$

So each time a new entry is added, the `phonebook` file will get re-sorted.

**Team LiB**

[← PREVIOUS](#)

[NEXT →](#)

## A Program to Remove Someone from the Phone Book

No set of programs that enable you to look up or add someone to the phone book would be complete without a program to remove someone from the phone book. We'll call the program `rem` and have it take as its argument the name of the person to be removed. What should the strategy be for developing the program? Essentially, you want to remove the line from the file that contains the specified name. The `-v` option to `grep` can be used here because it prints lines from a file that *don't* match a pattern:

```
$ cat rem
#
# Remove someone from the phone book
#
grep -v "$1" phonebook > /tmp/phonebook
mv /tmp/phonebook phonebook
$
```

The `grep` writes all lines that don't match into the file `/tmp/phonebook`. [\[1\]](#) After the `grep` is done, the old `phonebook` file is replaced by the new one from `/tmp`.

<sup>[1]</sup> `/tmp` is a directory on all Unix systems that anyone can write to. It's used by programs to create "temporary" files. Each time the system gets rebooted, all the files in `/tmp` are usually removed.

```
$ rem 'Stromboli Pizza'           Remove this entry
$ cat phonebook
Alice Chebba      973-555-2015
Barbara Swingle  201-555-9257
Billy Bach        201-555-7618
Liz Stachiw       212-555-2298
```

```
Susan Goldberg 201-555-7776
Susan Topple 212-555-4932
Tony Iannino 973-555-1295

$ rem Susan

$ cat phonebook

Alice Chebba 973-555-2015
Barbara Swingle 201-555-9257
Billy Bach 201-555-7618
Liz Stachiw 212-555-2298
Tony Iannino 973-555-1295

$
```

The first case, where `Stromboli Pizza` was removed, worked fine. In the second case, however, both `Susan` entries were removed because they both matched the pattern. You can use the `add` program to add them back to the phone book:

```
$ add 'Susan Goldberg' 201-555-7776

$ add 'Susan Topple' 212-555-4932

$
```

In [Chapter 8](#), "Decisions, Decisions," you'll learn how to determine whether more than one matching entry is found and take some other action if that's the case. For example, you might want to alert the user that more than one match has been found and further qualification of the name is required. (This can be very helpful, because most implementations of `grep` will match *everything* if an empty string is passed as the pattern.)

Incidentally, before leaving this program, note that `sed` could have also been used to delete the matching entry. In such a case, the `grep` could be replaced with

```
sed "/$1/d" phonebook > /tmp/phonebook
```

to achieve the same result. The double quotes are needed around the `sed` command to ensure that the value of `$1` is substituted, while at the same time ensuring that the shell doesn't see a command line like

```
sed /Stromboli Pizza/d phonebook > /tmp/phonebook
```

and pass three arguments to `sed` rather than two.

[Team LiB](#)

[← PREVIOUS](#)

[NEXT →](#)

`#{n}`

If you supply more than nine arguments to a program, you cannot access the tenth and greater arguments with `10`, `11`, and so on. If you try to access the tenth argument by writing

```
10
```

the shell actually substitutes the value of `1` followed by a `0`. Instead, the format

```
{n}
```

must be used. So to directly access argument 10, you must write

```
{10}
```

in your program.

## The `shift` Command

The `shift` command allows you to effectively *left shift* your positional parameters. If you execute the command

```
shift
```

whatever was previously stored inside `$2` will be assigned to `$1`, whatever was previously stored in `$3` will be assigned to `$2`, and so on. The old value of `$1` will be irretrievably lost.

When this command is executed, `$#` (the number of arguments variable) is also automatically decremented by one:

```
$ cat tshift                Program to test the shift
echo $# $*
shift
echo $# $*
shift
echo $# $*
shift
echo $# $*
shift
echo $# $*
shift
echo $# $*
shift
echo $# $*
$ tshift a b c d e
5 a b c d e
4 b c d e
```

```
3 c d e
2 d e
1 e
0
$
```

If you try to `shift` when there are no variables to shift (that is, when `$#` already equals zero), you'll get an error message from the shell (the error will vary from one shell to the next):

```
prog: shift: bad number
```

where *prog* is the name of the program that executed the offending `shift`.

You can shift more than one "place" at once by writing a *count* immediately after `shift`, as in

```
shift 3
```

This command has the same effect as performing three separate shifts:

```
shift
shift
shift
```

The `shift` command is useful when processing a variable number of arguments. You'll see it put to use when you learn about loops in [Chapter 9](#), "'Round and 'Round She Goes."



## Exercises

- 1: Modify `lu` so that it ignores case when doing the lookup.
- 2: What happens if you forget to supply an argument to the `lu` program? What happens if the argument is null (as in, `lu ""`)?
- 3: The program `ison` from this chapter has a shortcoming as shown in the following example:

```
$ ison ed
fred      tty03    Sep  4 14:53
$
```

The output indicates that `fred` is logged on, while we were checking to see whether `ed` was logged on.

Modify `ison` to correct this problem.

- 4: Write a program called `twice` that takes a single integer argument and doubles its value:

```
$ twice 15
30
$ twice 0
0
$
```

What happens if a noninteger value is typed? What if the argument is omitted?

- 5: Write a program called `home` that takes the name of a user as its single argument and prints that user's home directory. So

```
home steve
```

would print

```
/users/steve
```

if `/users/steve` is `steve`'s home directory. (Hint: Recall that the home directory is the sixth field stored in the file `/etc/passwd`.)

- 6: Write a program called `suffix` that renames a file by adding the characters given as the second argument to the end of the name of the file given as the first argument. So

```
suffix mem01 .sv
```

should rename `mem01` to `mem01.sv`.

- 7: Write a program called `unsuffix` that removes the characters given as the second argument from the end of the name of the file given as the first argument. So

```
unsuffix mem01.sv .sv
```

should rename `mem01.sv` to `mem01`. Be sure that the characters are removed from the end, so

```
unsuffix test1test test
```

should result in `test1test` being renamed to `test1`. (Hint: Use `sed` and command substitution.)

# Chapter 8. Decisions, Decisions

## IN THIS CHAPTER

- [Exit Status](#)
- [The `test` Command](#)
- [The `else` Construct](#)
- [The `exit` Command](#)
- [The `elif` Construct](#)
- [The `case` Command](#)
- [The Null Command `:`](#)
- [The `&&` and `||` Constructs](#)
- [Exercises](#)

This chapter introduces a statement that is present in almost all programming languages: `if`. It enables you to test a condition and then change the flow of program execution based on the result of the test.

The general format of the `if` command is

```
if commandt
then
    command
    command
    ...
fi
```

where *command*<sub>t</sub> is executed and its *exit status* is tested. If the exit status is zero, the commands that follow between the `then` and the `fi` are executed; otherwise, they are skipped.

## Exit Status

Whenever any program completes execution under the Unix system, it returns an exit status back to the system. This status is a number that usually indicates whether the program successfully ran. By convention, an exit status of zero indicates that a program succeeded, and nonzero indicates that it failed. Failures can be caused by invalid arguments passed to the program, or by an error condition detected by the program. For example, the `cp` command returns a nonzero exit status if the copy fails for some reason (for example, if it can't create the destination file), or if the arguments aren't correctly specified (for example, wrong number of arguments, or more than two arguments and the last one isn't a directory). In the case of `grep`, an exit status of zero (success) is returned if it finds the specified pattern in at least one of the files; a nonzero value is returned if it can't find the pattern or if an error occurs (the arguments aren't correctly specified, or it can't open one of the files).

In a pipeline, the exit status is that of the last command in the pipe. So in

```
who | grep fred
```

the exit status of the `grep` is used by the shell as the exit status for the pipeline. In this case, an exit status of zero means that `fred` was found in `who`'s output (that is, `fred` was logged on at the time that this command was executed).

## The `$?` Variable

The shell variable `$?` is automatically set by the shell to the exit status of the last command executed. Naturally, you can use `echo` to display its value at the terminal.

```
$ cp phonebook phone2
```

```
$ echo $?
```

```
0                               Copy "succeeded"
```

```
$ cp nosuch backup
```

```
cp: cannot access nosuch
```

```
$ echo $?
```

```
2                               Copy "failed"
```

```

$ who                               See who's logged on

root    console Jul 8 10:06

wilma   tty03    Jul 8 12:36

barney  tty04    Jul 8 14:57

betty   tty15    Jul 8 15:03

$ who | grep barney

barney  tty04    Jul 8 14:57

$ echo $?                             Print exit status of last command (grep)

0                                             grep "succeeded"

$ who | grep fred

$ echo $?

1                                             grep "failed"

$ echo $?

0                                             Exit status of last echo

$

```

Note that the numeric result of a "failure" for some commands can vary from one Unix version to the next, but success is always signified by a zero exit status.

Let's now write a shell program called `on` that tells us whether a specified user is logged on to the system. The name of the user to check will be passed to the program on the command line. If the user is logged on, we'll print a message to that effect; otherwise we'll say nothing. Here is the program:

```

$ cat on

#

# determine if someone is logged on

#

```

```
user="$1"

if who | grep "$user"
then
    echo "$user is logged on"
fi

$
```

This first argument typed on the command line is stored in the shell variable `user`. Then the `if` command executes the pipeline

```
who | grep "$user"
```

and tests the exit status returned by `grep`. If the exit status is zero, `grep` found `user` in `who`'s output. In that case, the `echo` command that follows is executed. If the exit status is nonzero, the specified user is not logged on, and the `echo` command is skipped. The `echo` command is indented from the left margin for aesthetic reasons only (tab characters are usually used for such purposes because it's easier to type a tab character than an equivalent number of spaces). In this case, just a single command is enclosed between the `then` and `fi`. When more commands are included, and when the nesting gets deeper, indentation can have a dramatic effect on the program's readability. Later examples will help illustrate this point.

Here are some sample uses of `on`:

```
$ who

root      console Jul  8 10:37
barney    tty03    Jul  8 12:38
fred      tty04    Jul  8 13:40
joanne    tty07    Jul  8 09:35
tony      tty19    Jul  8 08:30
lulu      tty23    Jul  8 09:55
```

```
$ on tony                We know he's on
tony    tty19    Jul 8 08:30    Where did this come from?
tony is logged on
$ on steve              We know he's not on
$ on ann                Try this one
joanne  tty07    Jul 8 09:35
ann is logged on
$
```

We seem to have uncovered a couple of problems with the program. When the specified user is logged on, the corresponding line from `who`'s output is also displayed. This may not be such a bad thing, but the program requirements called for only a message to be displayed and nothing else.

This line is displayed because not only does `grep` return an exit status in the pipeline

```
who | grep "$user"
```

but it also goes about its normal function of writing any matching lines to standard output, even though we're really not interested in that. We can dispose of `grep`'s output by redirecting it to the system's "garbage can," `/dev/null`. This is a special file on the system that anyone can read from (and get an immediate end of file) or write to. When you write to it, the bits go to that great bit bucket in the sky!

```
who | grep "$user" > /dev/null
```

The second problem with `on` appears when the program is executed with the argument `ann`. Even though `ann` is not logged on, `grep` matches the characters `ann` for the user `joanne`. What you need here is a more restrictive pattern specification, which you learned how to do in [Chapter 4](#), "Tools of the Trade," where we talked about regular expressions. Because `who` lists each username in column one of each output line, we can anchor the pattern to match the beginning of the line by preceding the pattern with the character `^`:

```
who | grep "^$user" > /dev/null
```

But that's not enough. `grep` still matches a line like

```
bobby    tty07  Jul 8 09:35
```

if you ask it to search for the pattern `bob`. What you need to do is also anchor the pattern on the right. Realizing that `who` ends each username with one or more spaces, the pattern

```
"^$user "
```

now only matches lines for the specified `user`.

Let's try the new and improved version of `on`:

```
$ cat on
#
# determine if someone is logged on -- version 2
#
user="$1"
```

```
if who | grep "^$user " > /dev/null
```

```
then
```

```
    echo "$user is logged on"
```

```
fi
```

```
$ who                Who's on now?
```

```
root    console Jul 8 10:37
```

```
barney  tty03    Jul 8 12:38
```

```
fred    tty04    Jul 8 13:40
```



```
joanne tty07 Jul 8 09:35
```

```
tony tty19 Jul 8 08:30
```

```
lulu tty23 Jul 8 09:55
```

```
$ on lulu
```

```
lulu is logged on
```

```
$ on ann Try this again
```

```
$ on What happens if we don't give any arguments?
```

```
$
```

If no arguments are specified, `user` will be null. `grep` will then look through `who`'s output for lines that start with a blank (why?). It won't find any, and so just a command prompt will be returned. In the next section, you'll see how to test whether the correct number of arguments has been supplied to a program and, if not, take some action.

## The `test` Command

A built-in shell command called `test` is most often used for testing one or more conditions in an `if` command. Its general format is

```
test expression
```

where *expression* represents the condition you're testing. `test` evaluates *expression*, and if the result is *true*, it returns an exit status of zero; otherwise, the result is *false*, and it returns a nonzero exit status.

## String Operators

As an example of the use of `test`, the following command returns a zero exit status if the shell variable `name` contains the characters `julio`:

```
test "$name" = julio
```

The `=` operator is used to test whether two values are identical. In this case, we're testing to see whether the *contents* of the shell variable `name` are identical to the characters `julio`. If it is, `test` returns an exit status of zero; nonzero otherwise.

Note that `test` must see all operands (`$name` and `julio`) and operators (`=`) as separate arguments, meaning that they must be delimited by one or more whitespace characters.

Getting back to the `if` command, to `echo` the message "Would you like to play a game?" if `name` contains the characters `julio`, you would write your `if` command like this:

```
if test "$name" = julio
then
    echo "Would you like to play a game?"
fi
```

(Why is it better to play it safe and enclose the message that is displayed by `echo` inside quotes?) When the `if` command gets executed, the command that follows the `if` is executed, and its exit status is tested. The `test` command is passed the three arguments `$name` (with its value substituted, of course), `=`, and `julio`. `test` then tests to see whether the first argument is identical to the third argument and returns a zero exit status if it is and a nonzero exit status if it is not.

The `exit` status returned by `test` is then tested. If it's zero, the commands between `then` and `fi` are executed; in this case, the single `echo` command is executed. If the exit status is nonzero, the `echo` command is skipped.

It's good programming practice to enclose shell variables that are arguments to `test` inside a pair of *double* quotes (to allow variable substitution). This ensures that `test` sees the argument in the case where its value is null. For example, consider the following example:

```
$ name=                               Set name null
$ test $name = julio
sh: test: argument expected
$
```

Because `name` was null, only two arguments were passed to `test`: `=` and `julio` because the shell substituted the value of `name` *before* parsing the command line into arguments. In fact, after `$name` was substituted by the shell, it was as if you typed the following:

```
test = julio
```

When `test` executed, it saw only two arguments (see [Figure 8.1](#)) and therefore issued the error message.

Figure 8.1. `test $name = julio` with `name` null.

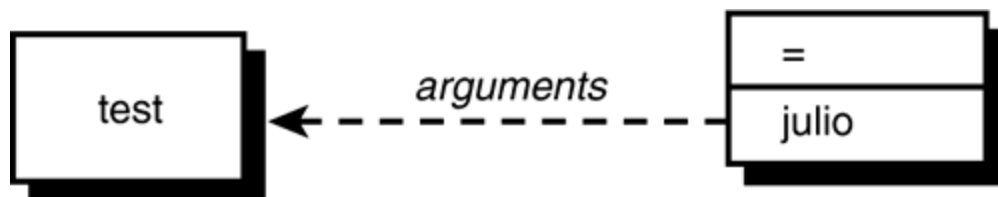

By placing double quotes around the variable, you ensure that `test` sees the argument because quotes act as a "placeholder" when the argument is null.

```

$ test "$name" = julio
$ echo $?          Print the exit status
1
$

```

Even if `name` is null, the shell still passes three arguments to `test`, the first one null (see [Figure 8.2](#)).

Figure 8.2. `test "$name" = julio` with `name` null.

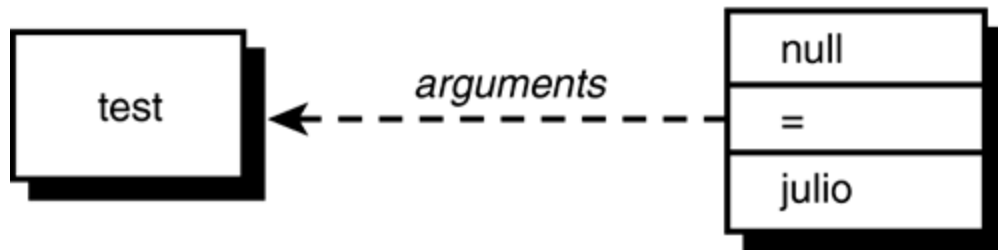

Other operators can be used to test character strings. These operators are summarized in [Table 8.1](#).

Table 8.1. `test` String Operators

Operator	Returns TRUE (exit status of 0) if
$string_1 = string_2$	$string_1$ is identical to $string_2$ .
$string_1 \neq string_2$	$string_1$ is <i>not</i> identical to $string_2$ .
$string$	$string$ is not null.
<code>-n string</code>	$string$ is not null (and $string$ must be seen by <code>test</code> ).
<code>-z string</code>	$string$ is null (and $string$ must be seen by <code>test</code> ).

You've seen how the `=` operator is used. The `!=` operator is similar, only it tests two strings for inequality. That is, the exit status from `test` is zero if the two strings are not equal, and nonzero if they are.

Let's look at three similar examples.

```

$ day="monday"
$ test "$day" = monday

```

```
$ echo $?  
  
0  
True  
  
$
```

The `test` command returns an exit status of 0 because the value of `day` is equal to the characters `monday`. Now look at the following:

```
$ day="monday "  
  
$ test "$day" = monday  
  
$ echo $?  
  
1  
False  
  
$
```

Here we assigned the characters `monday`—*including the space character that immediately followed*—to `day`. Therefore, when the previous test was made, `test` returned false because the characters `"monday "` were not identical to the characters `"monday"`.

If you wanted these two values to be considered equal, omitting the double quotes would have caused the shell to "eat up" the trailing space character, and `test` would have never seen it:

```
$ day="monday "  
  
$ test $day = monday  
  
$ echo $?  
  
0  
  
$ True
```

Although this seems to violate our rule about always quoting shell variables that are arguments to `test`, it's okay to omit the quotes if you're sure that the variable is not null (and not composed entirely of whitespace characters).

You can test to see whether a shell variable has a null value with the third operator listed in [Table 8.1](#):

```
test "$day"
```

This returns true if `day` is not null and false if it is. Quotes are not necessary here because `test` doesn't care whether it sees an argument in this case. Nevertheless, you are better off using them here as well because if the variable consists entirely of whitespace characters, the shell will get rid of the argument if not enclosed in quotes.

```
$ blanks="    "
$ test $blanks           Is it not null?
$ echo $?
1                       False—it's null
$ test "$blanks"        And now?
$ echo $?
0                       True—it's not null
$
```

In the first case, `test` was not passed *any* arguments because the shell ate up the four spaces in `blanks`. In the second case, `test` got one argument consisting of four space characters; obviously not null.

In case we seem to be belaboring the point about blanks and quotes, realize that this is a sticky area that is a frequent source of shell programming errors. It's good to really understand the principles here to save yourself a lot of programming headaches in the future.

There is another way to test whether a string is null, and that's with either of the last two operators listed previously in [Table 8.1](#). The `-n` operator returns an exit status of zero if the argument that follows is not null. Think of this operator as testing for nonzero length.

The `-z` operator tests the argument that follows to see whether it is null and returns an exit status of zero if it is. Think of this operator as testing to see whether the following argument has zero length.

So the command

```
test -n "$day"
```

returns an exit status of 0 if `day` contains at least one character. The command

```
test -z "$dataflag"
```

returns an exit status of 0 if `dataflag` doesn't contain any characters.

Be forewarned that both of the preceding operators expect an argument to follow; therefore, get into the habit of enclosing that argument inside double quotes.

```
$ nullvar=
$ nonnullvar=abc
$ test -n "$nullvar"           Does nullvar have nonzero length?
$ echo $?
1                               No
$ test -n "$nonnullvar"       And what about nonnullvar?
$ echo $?
0                               Yes
$ test -z "$nullvar"          Does nullvar have zero length?
$ echo $?
0                               Yes
$ test -z "$nonnullvar"       And nonnullvar?
$ echo $?
1                               No
$
```

Note that `test` can be picky about its arguments. For example, if the shell variable `symbol` contains

an equals sign, look at what happens if you try to test it for zero length:

```
$ echo $symbol
=
$ test -z "$symbol"
sh: test: argument expected
$
```

The `=` operator has higher precedence than the `-z` operator, so `test` expects an argument to follow. To avoid this sort of problem, you can write your command as

```
test X"$symbol" = X
```

which will be true if `symbol` is null, and false if it's not. The `x` in front of `symbol` prevents `test` from interpreting the characters stored in `symbol` as an operator.

## An Alternative Format for `test`

The `test` command is used so often by shell programmers that an alternative format of the command is recognized. This format improves the readability of the command, especially when used in `if` commands.

You'll recall that the general format of the `test` command is

```
test expression
```

This can also be expressed in the alternative format as

```
[ expression ]
```

The `[` is actually the name of the command (who said anything about command names having to be



alphanumeric characters?). It still initiates execution of the same `test` command, only in this format, `test` expects to see a closing `]` at the end of the expression. Naturally, spaces must appear after the `[` and before the `]`.

You can rewrite the `test` command shown in a previous example with this alternative format as shown:

```
$ [ -z "$nonnullvar" ]  
  
$ echo $?  
  
1  
  
$
```

When used in an `if` command, this alternative format looks like this:

```
if [ "$name" = julio ]  
then  
    echo "Would you like to play a game?"  
fi
```

Which format of the `if` command you use is up to you; we prefer the `[...]` format, so that's what we'll use throughout the remainder of the book.

## Integer Operators

`test` has an assortment of operators for performing integer comparisons. [Table 8.2](#) summarizes these operators.

Table 8.2. `test` Integer Operators

Operator	Returns TRUE (exit status of 0) if
<code>int<sub>1</sub> -eq int<sub>2</sub></code>	<code>int<sub>1</sub></code> is equal to <code>int<sub>2</sub></code> .
<code>int<sub>1</sub> -ge int<sub>2</sub></code>	<code>int<sub>1</sub></code> is greater than or equal to <code>int<sub>2</sub></code> .

Operator Returns TRUE (exit status of 0) if

`int1 -gt int2` `int1` is greater than `int2`.

`int1 -le int2` `int1` is less than or equal to `int2`.

`int1 -lt int2` `int1` is less than `int2`.

`int1 -ne int2` `int1` is not equal to `int2`.

For example, the operator `-eq` tests to see whether two integers are equal. So if you had a shell variable called `count` and you wanted to see whether its value was equal to zero, you would write

```
[ "$count" -eq 0 ]
```

Other integer operators behave similarly, so

```
[ "$choice" -lt 5 ]
```

tests to see whether the variable `choice` is less than 5; the command

```
[ "$index" -ne "$max" ]
```

tests to see whether the value of `index` is not equal to the value of `max`; and, finally

```
[ "$#" -ne 0 ]
```

tests to see whether the number of arguments passed to the command is not equal to zero.

The `test` command interprets the value as an integer when an integer operator is used, and not the shell, so these comparisons work regardless of the shell variable's type.

Let's reinforce the difference between `test`'s string and integer operators by taking a look at a few examples.

```
$ x1="005"
```

```

$ x2=" 10"

$ [ "$x1" = 5 ]           String comparison

$ echo $?

1                          False

$ [ "$x1" -eq 5 ]        Integer comparison

$ echo $?

0                          True

$ [ "$x2" = 10 ]        String comparison

$ echo $?

1                          False

$ [ "$x2" -eq 10 ]      Integer comparison

$ echo $?

0                          True

$

```

The first test

```
[ "$x1" = 5 ]
```

uses the string comparison operator `=` to test whether the two strings are identical. They're not, because the first string is composed of the three characters `005`, and the second the single character `5`.

In the second test, the integer comparison operator `-eq` is used. Treating the two values as integers, `005` is equal to `5`, as verified by the exit status returned by `test`.

The third and fourth tests are similar, only in this case you can see how even a leading space stored in the variable `x2` can influence a test made with a string operator versus one made with an integer operator.

## File Operators

Virtually every shell program deals with one or more files. For this reason, a wide assortment of operators is provided by `test` to enable you to ask various questions about files. Each of these operators is *unary* in nature, meaning that they expect a single argument to follow. In all cases, this argument is the name of a file (and that includes a directory file, of course).

[Table 8.3](#) lists the commonly used file operators.

Table 8.3. Commonly Used `test` File Operators

Operator	Returns TRUE (exit status of 0) if
<code>-d file</code>	<i>file</i> is a directory.
<code>-e file</code>	<i>file</i> exists.
<code>-f file</code>	<i>file</i> is an ordinary file.
<code>-r file</code>	<i>file</i> is readable by the process.
<code>-s file</code>	<i>file</i> has nonzero length.
<code>-w file</code>	<i>file</i> is writable by the process.
<code>-x file</code>	<i>file</i> is executable.
<code>-L file</code>	<i>file</i> is a symbolic link.

The command

```
[ -f /users/steve/phonebook ]
```

tests whether the file `/users/steve/phonebook` exists and is an ordinary file (that is, not a directory and not a special file).

The command

```
[ -r /users/steve/phonebook ]
```

tests whether the indicated file exists and is also readable by you.

The command

```
[ -s /users/steve/phonebook ]
```

tests whether the indicated file contains at least one byte of information in it. This is useful, for example, if you create an error log file in your program and you want to see whether anything was written to it:

```
if [ -s $ERRFILE ]
then
    echo "Errors found:"
    cat $ERRFILE
fi
```

A few more `test` operators, when combined with the previously described operators, enable you to make more complex types of tests.

## The Logical Negation Operator !

The unary logical negation operator `!` can be placed in front of any other `test` expression to *negate* the result of the evaluation of that expression. For example,

```
[ ! -r /users/steve/phonebook ]
```

returns a zero exit status (true) if `/users/steve/phonebook` is *not* readable; and

```
[ ! -f "$mailfile" ]
```

returns true if the file specified by `$mailfile` does *not* exist or is not an ordinary file. Finally,

```
[ ! "$x1" = "$x2" ]
```

returns true if `$x1` is not identical to `$x2` and is obviously equivalent to

```
[ "$x1" != "$x2" ]
```

## The Logical AND Operator `-a`

The operator `-a` performs a logical *AND* of two expressions and returns true only if the two joined expressions are both true. So

```
[ -f "$mailfile" -a -r "$mailfile" ]
```

returns true if the file specified by `$mailfile` is an ordinary file and is readable by you. An extra space was placed around the `-a` operator to aid in the expression's readability and obviously has no effect on its execution.

The command

```
[ "$count" -ge 0 -a "$count" -lt 10 ]
```

will be true if the variable `count` contains an integer value greater than or equal to zero but less than 10. The `-a` operator has lower *precedence* than the integer comparison operators (and the string and file operators, for that matter), meaning that the preceding expression gets evaluated as

```
("$count" -ge 0) -a ("$count" -lt 10)
```

as you would expect.

## Parentheses

Incidentally, you *can* use parentheses in a `test` expression to alter the order of evaluation; just make sure that the parentheses are quoted because they have a special meaning to the shell. So to translate the preceding example into a `test` command, you would write

```
[ \ ( " $count" -ge 0 \ ) -a \ ( " $count" -lt 10 \ ) ]
```

As is typical, spaces must surround the parentheses because `test` expects to see them as separate arguments.

## The Logical OR Operator `-o`

The `-o` operator is similar to the `-a` operator, only it forms a logical *OR* of two expressions. That is, evaluation of the expression will be true if *either* the first expression is true or the second expression is true.

```
[ -n "$mailopt" -o -r $HOME/mailfile ]
```

This command will be true if the variable `mailopt` is not null *or* if the file `$HOME/mailfile` is readable by you.

The `-o` operator has lower precedence than the `-a` operator, meaning that the expression

```
"$a" -eq 0 -o "$b" -eq 2 -a "$c" -eq 10
```

gets evaluated by `test` as

```
"$a" -eq 0 -o ( "$b" -eq 2 -a "$c" -eq 10 )
```

Naturally, you can use parentheses to change this order if necessary:

```
\ ( "$a" -eq 0 -o "$b" -eq 2 \ ) -a "$c" -eq 10
```

You will see many uses of the `test` command throughout the book. [Table A.11](#) in [Appendix A](#), "Shell Summary," summarizes all available `test` operators.

## The `else` Construct

A construct known as the `else` can be added to the `if` command, with the general format as shown:

```
if commandt
then
    command
    command
    ...
else
    command
    command
    ...
fi
```

Execution of this form of the command starts as before; *command*<sub>t</sub> is executed and its exit status tested. If it's zero, the commands that follow between the `then` and the `else` are executed, and the commands between the `else` and `fi` are skipped. Otherwise, the exit status is nonzero and the commands between the `then` and `else` are skipped and the commands between the `else` and `fi` are executed. In either case, only one set of commands gets executed: the first set if the exit status is zero, and the second set if it's nonzero.

Let's now write a modified version of `on`. Instead of printing nothing if the requested user is not logged on, we'll have the program print a message to that effect. Here is version 3 of the program:

```
$ cat on
#
# determine if someone is logged on -- version 3
#
```



```
user="$1"

if who | grep "^$user " > /dev/null
then
    echo "$user is logged on"
else
    echo "$user is not logged on"
fi

$
```

If the user specified as the first argument to `on` is logged on, the `grep` will succeed and the message `$user is logged on` will be displayed; otherwise, the message `$user is not logged on` will be displayed.

```
$ who                Who's on?
root      console Jul  8 10:37
barney    tty03      Jul  8 12:38
fred      tty04      Jul  8 13:40
joanne    tty07      Jul  8 09:35
tony      tty19      Jul  8 08:30
lulu      tty23      Jul  8 09:55

$ on pat
pat is not logged on

$ on tony
tony is logged on

$
```

Another nice touch when writing shell programs is to make sure that the correct number of arguments is passed to the program. If an incorrect number is supplied, an error message to that effect can be displayed, together with information on the proper usage of the program.

```
$ cat on
#
# determine if someone is logged on -- version 4
#
#
# see if the correct number of arguments were supplied
#
if [ "$#" -ne 1 ]
then
    echo "Incorrect number of arguments"
    echo "Usage: on user"
else
    user="$1"

    if who | grep "^$user " > /dev/null
    then
        echo "$user is logged on"
    else
        echo "$user is not logged on"
    fi
fi
$
```

Compare this program with the previous version and note the changes that were made. An additional `if` command was added to test whether the correct number of arguments was supplied. If `$#` is not equal to 1, the program prints two messages; otherwise, the commands after the `else` clause are executed. These commands are the same as appeared in the last version of `on`: They assign `$1` to `user` and then see whether `user` is logged on, printing a message in either case. Note that two `fi`s are required because two `if` commands are used.

The indentation used goes a long way toward aiding the program's readability. Make sure that you get into the habit of setting and following indentation rules in your programs.

```
$ on No arguments
```

```
Incorrect number of arguments
```

```
Usage: on user
```

```
$ on priscilla One argument
```

```
priscilla is not logged on
```

```
$ on jo anne Two arguments
```

```
Incorrect number of arguments
```

```
Usage: on user
```

```
$
```

## The `exit` Command

A built-in shell command called `exit` enables you to immediately terminate execution of your shell program. The general format of this command is

```
exit n
```

where `n` is the exit status that you want returned. If none is specified, the exit status used is that of the last command executed before the `exit`.

Be advised that executing the `exit` command directly from your terminal will log you off the system because it will have the effect of terminating execution of your login shell.

## A Second Look at the `rem` Program

`exit` is frequently used as a convenient way to terminate execution of a shell program. For example, let's take another look at the `rem` program, which removes an entry from the `phonebook` file:

```
$ cat rem
#
# Remove someone from the phone book
#

grep -v "$1" phonebook > /tmp/phonebook
mv /tmp/phonebook phonebook
$
```

This program has the potential to do unintended things to the `phonebook` file. For example, suppose that you type

```
rem Susan Topple
```

Here the shell will pass two arguments to `rem`. The `rem` program will end up removing all `Susan` entries, as specified by `$1`.

It's always best to take precautions with a potentially destructive program like `rem` and to be certain as possible that the action intended by the user is consistent with the action that the program is taking.

One of the first checks that can be made in `rem` is for the correct number of arguments, as was done before with the `on` program. This time, we'll use the `exit` command to terminate the program if the correct number of arguments isn't supplied:

```
$ cat rem
#
# Remove someone from the phone book -- version 2
#
if [ "$#" -ne 1 ]
then
    echo "Incorrect number of arguments."
    echo "Usage: rem name"
    exit 1
fi

grep -v "$1" phonebook > /tmp/phonebook
mv /tmp/phonebook phonebook

$ rem Susan Goldberg           Try it out
Incorrect number of arguments.
Usage: rem name
$
```

The `exit` command returns an exit status of 1, to signal "failure," in case some other program wants to check it. How could you have written the preceding program with an `if-else` instead of using the `exit` (hint: look at the last version of `on`)?

Whether you use the `exit` or an `if-else` is up to you. Sometimes the `exit` is a more convenient way to get out of the program quickly, particularly if it's done early in the program.

Team LiB

◀ PREVIOUS

NEXT ▶

## The `elif` Construct

As your programs become more complex, you may find yourself needing to write nested `if` statements of the following form:

```
if command1
then
    command
    command
    ...
else
    if command2
    then
        command
        command
        ...
    else
        ...
        if commandn
        then
            command
            command
            ...
        else
            command
```

```
                command
                ...
            fi
            ...
        fi
fi
```

This type of command sequence is useful when you need to make more than just a two-way decision as afforded by the `if-else` construct. In this case, a multiway decision is made, with the last `else` clause executed if none of the preceding conditions is satisfied.

As an example, suppose that you wanted to write a program called `greetings` that would print a friendly "Good morning," "Good afternoon," or "Good evening" whenever you logged on to the system. For purposes of the example, consider any time from midnight to noon to be the morning, noon to 6:00 p.m. the afternoon, and 6:00 p.m. to midnight the evening.

To write this program, you have to find out what time it is. `date` serves just fine for this purpose. Take another look at the output from this command:

```
$ date
Wed Aug 29 10:42:01 EDT 2002
$
```

The format of `date`'s output is fixed, a fact that you can use to your advantage when writing `greetings` because this means that the time will always appear in character positions 12 through 19. Actually, for this program, you really only need the hour displayed in positions 12 and 13. So to get the hour from `date`, you can write

```
$ date | cut -c12-13
10
$
```

Now the task of writing the `greetings` program is straightforward:



```
$ cat greetings
#
# Program to print a greeting
#

hour=$(date | cut -c12-13)

if [ "$hour" -ge 0 -a "$hour" -le 11 ]
then
    echo "Good morning"
else
    if [ "$hour" -ge 12 -a "$hour" -le 17 ]
    then
        echo "Good afternoon"
    else
        echo "Good evening"
    fi
fi

$
```

If `hour` is greater than or equal to 0 (midnight) and less than or equal to 11 (up to 11:59:59), "Good morning" is displayed. If `hour` is greater than or equal to 12 (noon) and less than or equal to 17 (up to 5:59:59 p.m.), "Good afternoon" is displayed. If neither of the preceding two conditions is satisfied, "Good evening" is displayed.

```
$ greetings
Good morning
```

\$

As noted, the nested `if` command sequence used in `greetings` is so common that a special `elif` construct is available to more easily express this sequence. The general format of this construct is

```
if command1
then
    command
    command
    ...
elif command2
then
    command
    command
    ...
elif commandn
then
    command
    command
    ...
else
    command
    command
    ...
fi
```

*command<sub>1</sub>, command<sub>2</sub>, ..., command<sub>n</sub>* are executed in turn and their exit statuses tested. As soon as one returns an exit status of zero, the commands listed after the **then** that follows are executed up to another **elif**, **else**, or **fi**. If none of the commands returns a zero exit status, the commands listed after the optional **else** are executed.

You could rewrite the **greetings** program using this new format as shown:

```
$ cat greetings
#
# Program to print a greeting -- version 2
#
hour=$(date | cut -c12-13)
if [ "$hour" -ge 0 -a "$hour" -le 11 ]
then
    echo "Good morning"
elif [ "$hour" -ge 12 -a "$hour" -le 17 ]
then
    echo "Good afternoon"
else
    echo "Good evening"
fi
$
```

This version is easier to read, and it doesn't have the tendency to disappear off the right margin due to excessive indentation. Incidentally, you should note that **date** provides a wide assortment of options. One of these, **%H**, can be used to get the hour directly from **date**:

```
$ date +%H
```

10

\$

As an exercise, you should change `greetings` to make use of this fact.

## Yet Another Version of `rem`

Another way to add some robustness to the `rem` program would be to check the *number* of entries that matched before doing the removal. If there's more than one match, you could issue a message to the effect and then terminate execution of the program. But how do you determine the number of matching entries? One approach is to do a normal `grep` on the `phonebook` file and then count the number of matches that come out with `wc`. If the number of matches is greater than one, the appropriate message can be issued.

```
$ cat rem

#

# Remove someone from the phone book -- version 3

#

if [ "$#" -ne 1 ]

then

    echo "Incorrect number of arguments."

    echo "Usage: rem name"

    exit 1

fi

name=$1

#

# Find number of matching entries
```

```

#

matches=$(grep "$name" phonebook | wc -l)

#
# If more than one match, issue message, else remove it
#

if [ "$matches" -gt 1 ]
then
    echo "More than one match; please qualify further"
elif [ "$matches" -eq 1 ]
then
    grep -v "$name" phonebook > /tmp/phonebook
    mv /tmp/phonebook phonebook
else
    echo "I couldn't find $name in the phone book"
fi
$

```

The positional parameter `$1` is assigned to the variable `name` after the number of arguments check is performed to add readability to the program. Subsequently using `$name` is a lot clearer than using `$1`.

The `if...elif...else` command first checks to see whether the number of matches is greater than one. If it is, the "More than one match" message is printed. If it's not, a test is made to see whether the number of matches is equal to one. If it is, the entry is removed from the phone book. If it's not, the number of matches must be zero, in which case a message is displayed to alert the user of this fact.

Note that the `grep` command is used twice in this program: first to determine the number of matches and then with the `-v` option to remove the single matching entry.

Here are some sample runs of the third version of `rem`:

```
$ rem
```

```
Incorrect number of arguments.
```

```
Usage: rem name
```

```
$ rem Susan
```

```
More than one match; please qualify further
```

```
$ rem 'Susan Topple'
```

```
$ rem 'Susan Topple'
```

```
I couldn't find Susan Topple in the phone book    She's history
```

```
$
```

Now you have a fairly robust `rem` program: It checks for the correct number of arguments, printing the proper usage if the correct number isn't supplied; it also checks to make sure that precisely one entry is removed from the `phonebook` file.

[Team LiB](#)

[◀ PREVIOUS](#)

[NEXT ▶](#)

## The `case` Command

The `case` command allows you to compare a single value against other values and to execute one or more commands when a match is found. The general format of this command is

```
case value in
    pat1)  command
           command
           ...
           command;;
    pat2)  command
           command
           ...
           command;;
    ...
    patn)  command
           command
           ...
           command;;
esac
```

The word *value* is successively compared against the values *pat<sub>1</sub>*, *pat<sub>2</sub>*, ..., *pat<sub>n</sub>*, until a match is found. When a match is found, the commands listed after the matching value, up to the double semicolons, are executed. After the double semicolons are reached, execution of the `case` is terminated. If a match is not found, none of the commands listed in the case is executed.

As an example of the use of the `case`, the following program called `number` takes a single digit and translates it to its English equivalent:

```
$ cat number
#
# Translate a digit to English
#

if [ "$#" -ne 1 ]
then
    echo "Usage: number digit"
    exit 1
fi

case "$1"
in
    0) echo zero;;
    1) echo one;;
    2) echo two;;
    3) echo three;;
    4) echo four;;
    5) echo five;;
    6) echo six;;
    7) echo seven;;
    8) echo eight;;
    9) echo nine;;
esac

$
```



Now to test it:

```
$ number 0
```

```
zero
```

```
$ number 3
```

```
three
```

```
$ number          Try no arguments
```

```
Usage: number digit
```

```
$ number 17       Try a two-digit number
```

```
$
```

The last case shows what happens when you type in more than one digit: `$1` doesn't match any of the values listed in the `case`, so none of the `echo` commands is executed.

## Special Pattern Matching Characters

The shell lets you use the same special characters for specifying the patterns in a `case` as you can with filename substitution. That is, `?` can be used to specify any single character; `*` can be used to specify zero or more occurrences of any character; and `[...]` can be used to specify any single character enclosed between the brackets.

Because the pattern `*` matches *anything* (just as when it's used for filename substitution it matches all the files in your directory), it's frequently used at the end of the `case` as the "catchall" value. That is, if none of the previous values in the `case` match, this one is guaranteed to match. Here's a second version of the `number` program that has such a catchall case.

```
$ cat number
```

```
#
```

```
# Translate a digit to English -- version 2
```

```
#
```

```
if [ "$#" -ne 1 ]
```

```
then
    echo "Usage: number digit"
    exit 1
fi

case "$1"
in
    0) echo zero;;
    1) echo one;;
    2) echo two;;
    3) echo three;;
    4) echo four;;
    5) echo five;;
    6) echo six;;
    7) echo seven;;
    8) echo eight;;
    9) echo nine;;
    *) echo "Bad argument; please specify a single digit";;
esac

$ number 9
nine
$ number 99
Bad argument; please specify a single digit
$
```

Here's another program called `ctype` that prints the type of the single character given as an argument. Character types recognized are digits, uppercase letters, lowercase letters, and special

characters (anything not in the first three categories). As an added check, the program makes sure that just a single character is given as the argument.

```
$ cat ctype
#
# Classify character given as argument
#
if [ $# -ne 1 ]
then
    echo Usage: ctype char
    exit 1
fi
#
# Ensure that only one character was typed
#
char="$1"
numchars=$(echo "$char" | wc -c)
if [ "$numchars" -ne 1 ]
then
    echo Please type a single character
    exit 1
fi
```

```
#  
# Now classify it  
#  
  
case "$char"  
in  
    [0-9] ) echo digit;;  
    [a-z] ) echo lowercase letter;;  
    [A-Z] ) echo uppercase letter;;  
    *      ) echo special character;;  
esac  
$
```

Some sample runs:

```
$ ctype a  
Please type a single character  
$ ctype 7  
Please type a single character  
$
```

## The `-x` Option for Debugging Programs

Something seems to be amiss. The counting portion of our program doesn't seem to be working properly. This seems like a good point to introduce the shell's `-x` option. You can trace the execution of any program by typing `sh -x` followed by the name of the program and its arguments. This starts up a new shell to execute the indicated program with the `-x` option enabled. In this mode, commands are printed at the terminal as they are executed, preceded by a plus sign. Let's try it out.

```

$ sh -x ctype a           Trace execution
+ [ 1 -ne 1 ]            $# equals 1
+ char=a                Assignment of $1 to char
+ echo a
+ wc -c
+ numchars=          2      wc returned 2???
+ [          2 -ne 1 ]     That's why this test succeeded
+ echo please type a single character
please type a single character
+ exit 1
$

```

The trace output indicates that `wc` returned 2 when

```
echo "$char" | wc -c
```

was executed. But why? There seemed to be only one character in `wc`'s input. The truth of the matter is that two characters were actually given to `wc`: the single character `a` and the "invisible" newline character that `echo` automatically prints at the end of each line. So the program really should be testing for the number of characters equal to two: the character typed plus the newline added by `echo`.

Go back to the `ctype` program and replace the `if` command that reads

```

if [ "$numchars" -ne 1 ]
then
    echo Please type a single character
    exit 1
fi

```

with

```
if [ "$numchars" -ne 2 ]
then
    echo Please type a single character
    exit 1
fi
```

and try it again.

```
$ ctype a
lowercase letter
$ ctype abc
Please type a single character
$ ctype 9
digit
$ ctype K
uppercase letter
$ ctype :
special character
$ ctype
Usage: ctype char
$
```

Now it seems to work just fine. (What do you think happens if you use `ctype *` without enclosing the `*` in quotes?)

In [Chapter 12](#), "More on Parameters," you'll learn how you can turn this trace feature on and off at will from *inside* your program.

Before leaving the `ctype` program, here's a version that avoids the use of `wc` and handles everything with the `case`:

```
$ cat ctype
#
# Classify character given as argument -- version 2
#
if [ $# -ne 1 ]
then
    echo Usage: ctype char
    exit 1
fi
#
# Now classify char, making sure only one was typed
#
char=$1
case "$char"
in
    [0-9] ) echo digit;;
    [a-z] ) echo lowercase letter;;
    [A-Z] ) echo uppercase letter;;
```

```
    ?    ) echo special character;;
    *    ) echo Please type a single character;;
esac

$
```

The `?` matches any single character. If this pattern is matched, the character is a special character. If this pattern isn't matched, more than one character was typed, so the catchall case is executed to print the message.

```
$ ctype u
lowercase letter

$ ctype '>'
special character

$ ctype xx
Please type a single character

$
```

## Back to the `case`

The symbol `|` has the effect of a logical OR when used between two patterns. That is, the pattern

```
pat1 | pat2
```

specifies that either *pat*<sub>1</sub> or *pat*<sub>2</sub> is to be matched. For example,

```
-l | -list
```

matches either the value `-l` or `-list`, and



```
dmd | 5620 | tty5620
```

matches either `dmd` or `5620` or `tty5620`.

The `greetings` program that you saw earlier in this chapter can be rewritten to use a `case` statement rather than the `if-elif`. Here is such a version of the program. This time, we took advantage of the fact that `date` with the `+%H` option writes a two-digit hour to standard output.

```
$ cat greetings
#
# Program to print a greeting -- case version
#
hour=$(date +%H)

case "$hour"
in
    0? | 1[01] ) echo "Good morning";;
    1[2-7]      ) echo "Good afternoon";;
    *           ) echo "Good evening";;
esac
$
```

The two-digit hour obtained from `date` is assigned to the shell variable `hour`. Then the `case` statement is executed. The value of `hour` is compared against the first pattern:

```
0? | 1[01]
```

which matches any value that starts with a zero followed by any character (midnight through 9:00 a.m.), or any value that starts with a one and is followed by a zero or one (10:00 or 11:00 a.m.).

The second pattern

```
1[2-7]
```

matches a value that starts with a one and is followed by any one of the digits two through seven (noon through 5:00 p.m.).

The last case, the catchall, matches anything else (6:00 p.m. through 11:00 p.m.).

```
$ date
```

```
Wed Aug 28 15:45:12 EDT 2002
```

```
$ greetings
```

```
Good afternoon
```

```
$
```

## The Null Command :

This seems about as good a time as any to talk about the shell's built-in *null* command. The format of this command is simply

```
:
```

and the purpose of it is—you guessed it—to do nothing. So what good is it? Well, in most cases it's used to satisfy the requirement that a command appear, particularly in `if` commands. Suppose that you want to make sure that the value stored in the variable `system` exists in the file `/users/steve/mail/systems`, and if it doesn't, you want to issue an error message and exit from the program. So you start by writing something like

```
if grep "^$system" /users/steve/mail/systems > /dev/null
then
```

but you don't know what to write after the `then` because you want to test for the nonexistence of the `system` in the file and don't want to do anything special if the `grep` succeeds. Unfortunately, the shell requires that you write a command after the `then`. Here's where the null command comes to the rescue:

```
if grep "^$system" /users/steve/mail/systems > /dev/null
then
    :
else
    echo "$system is not a valid system"
    exit 1
fi
```

So if the `system` is valid, nothing is done. If it's not valid, the error message is issued and the

program exited.

Remember this simple command when these types of situations arise.

**Team LiB**

[← PREVIOUS](#)

[NEXT →](#)

## The `&&` and `||` Constructs

The shell has two special constructs that enable you to execute a command based on whether the preceding command succeeds or fails. In case you think this sounds similar to the `if` command, well it is. It's sort of a shorthand form of the `if`.

If you write

```
command1 && command2
```

anywhere where the shell expects to see a command, *command*<sub>1</sub> will be executed, and if it returns an exit status of zero, *command*<sub>2</sub> will be executed. If *command*<sub>1</sub> returns an exit status of nonzero, *command*<sub>2</sub> gets skipped.

For example, if you write

```
sort bigdata > /tmp/sortout && mv /tmp/sortout bigdata
```

then the `mv` command will be executed only if the `sort` is successful. Note that this is equivalent to writing

```
if sort bigdata > /tmp/sortout
then
    mv /tmp/sortout bigdata
fi
```

The command

```
[ -z "$EDITOR" ] && EDITOR=/bin/ed
```

tests the value of the variable `EDITOR`. If it's null, `/bin/ed` is assigned to it.

The `||` construct works similarly, except that the second command gets executed only if the exit status of the first is nonzero. So if you write

```
grep "$name" phonebook || echo "Couldn't find $name"
```

the `echo` command will get executed only if the `grep` fails (that is, if it can't find `$name` in `phonebook`, or if it can't open the file `phonebook`). In this case, the equivalent `if` command would look like

```
if grep "$name" phonebook
then
    :
else
    echo "Couldn't find $name"
fi
```

You can write a pipeline on either the left- or right-hand sides of these constructs. On the left, the exit status tested is that of the last command in the pipeline; thus

```
who | grep "^$name " > /dev/null || echo "$name's not logged on"
```

causes execution of the `echo` if the `grep` fails.

The `&&` and `||` can also be combined on the same command line:

```
who | grep "^$name " > /dev/null && echo "$name's not logged on" \  
    || echo "$name is logged on"
```

(Recall that when `\` is used at the end of the line, it signals line continuation to the shell.) The first `echo` gets executed if the `grep` succeeds; the second if it fails.

These constructs are also often used in `if` commands:

```
if validsys "$sys" && timeok
then
    sendmail "$user@$sys" < $message
fi
```

If `validsys` returns an exit status of zero, `timeok` is executed. The exit status from this program is then tested for the `if`. If it's zero, then the `sendmail` program is executed. If `validsys` returns a nonzero exit status, `timeok` is not executed, and this is used as the exit status that is tested by the `if`. In that case, `sendmail` won't be executed.

The use of the `&&` operator in the preceding case is like a "logical AND"; both programs must return an exit status of zero for the `sendmail` program to be executed. In fact, you could have even written the preceding `if` as

```
validsys "$sys" && timeok && sendmail "$user@$sys" < $message
```

When the `||` is used in an `if`, the effect is like a "logical OR":

```
if endofmonth || specialrequest
then
    sendreports
fi
```

If `endofmonth` returns a zero exit status, `sendreports` is executed; otherwise, `specialrequest` is executed and if its exit status is zero, `sendreports` is executed. The net effect is that `sendreports` is executed if `endofmonth` or `specialrequest` return an exit status of zero.

In [Chapter 9](#), "'Round and 'Round She Goes," you'll learn about how to write loops in your programs. However, before proceeding to that chapter, try the exercises that follow.

## Exercises

- 1: Write a program called `valid` that prints "yes" if its argument is a valid shell variable name and "no" otherwise:

```
$ valid foo_bar
```

```
yes
```

```
$ valid 123
```

```
no
```

```
$
```

(Hint: Define a regular expression for a valid variable name and then enlist the aid of `grep` or `sed`.)

- 2: Write a program called `t` that displays the time of day in a.m. or p.m. notation rather than in 24-hour clock time. Here's an example showing `t` run at night:

```
$ date
```

```
Wed Aug 28 19:34:01 EDT 2002
```

```
$ t
```

```
7:21 pm
```

```
$
```

Use the shell's built-in integer arithmetic to convert from 24-hour clock time. Then rewrite the program to use a `case` command instead. Rewrite it again to perform arithmetic with the `expr` command.

- 3: Write a program called `mysed` that applies the `sed` script given as the first argument against the file given as the second. If the `sed` succeeds (that is, exit status of zero), replace the original file with the modified one. So



```
mysed '1,10d' text
```

will use `sed` to delete the first 10 lines from `text`, and, if successful, will replace `text` with the modified file.

- 4: Write a program called `isyes` that returns an exit status of 0 if its argument is "yes," and 1 otherwise. For purposes of this exercise, consider `y`, `yes`, `Yes`, `YES`, and `Y` all to be valid "yes" arguments:

```
$ isyes yes
```

```
$ echo $?
```

```
0
```

```
$ isyes no
```

```
$ echo $?
```

```
1
```

```
$
```

Write the program using an `if` command and then rewrite it using a `case` command. This program can be useful when reading yes/no responses from the terminal (which you'll learn about in [Chapter 10](#), "Reading and Printing Data").

- 5: Use the `date` and `who` commands to write a program called `conntime` that prints the number of hours and minutes that a user has been logged on to the system (assume that this is less than 24 hours).

# Chapter 9. 'Round and 'Round She Goes

## IN THIS CHAPTER

- [The `for` Command](#)
- [The `until` Command](#)
- [More on Loops](#)
- [The `getopts` Command](#)
- [Exercises](#)

In this chapter you'll learn how to set up program loops. These loops will enable you to execute repeatedly a set of commands either a specified number of times or until some condition is met. The three built-in looping commands are

- `for`
- `while`
- `until`

You'll learn about each one of these loops in separate sections of this chapter.

## The `for` Command

The `for` command is used to execute a set of commands a specified number of times. Its basic format is as shown:

```
for var in word1 word2 ... wordn
do
    command
    command
    ...
done
```

The commands enclosed between the `do` and the `done` form what's known as the *body* of the loop. These commands are executed for as many words as you have listed after the `in`. When the loop is executed, the first word, *word<sub>1</sub>*, is assigned to the variable *var*, and the body of the loop is then executed. Next, the second word in the list, *word<sub>2</sub>*, is assigned to *var*, and the body of the loop is executed. This process continues with successive words in the list being assigned to *var* and the commands in the loop body being executed until the last word in the list, *word<sub>n</sub>*, is assigned to *var* and the body of the loop executed. At that point, no words are left in the list, and execution of the `for` command is then finished. Execution then continues with the command that immediately follows the `done`. So if there are *n* words listed after the `in`, the body of the loop will have been executed a total of *n* times after the loop has finished.

Here's a loop that will be executed a total of three times:

```
for i in 1 2 3
do
    echo $i
done
```

To try it out, you can type this in directly at the terminal, just like any other shell command:

```
$ for i in 1 2 3
> do
>     echo $i
> done
1
2
3
$
```

While the shell is waiting for the `done` to be typed to close off the `for` command, it displays your secondary command prompt. When it gets the `done`, the shell then proceeds to execute the loop. Because three words are listed after the `in` (`1`, `2`, and `3`), the body of the loop—in this case a single `echo` command—will be executed a total of three times.

The first time through the loop, the first word in the list, `1`, is assigned to the variable `i`. Then the body of the loop is executed. This displays the value of `i` at the terminal. Then the next word in the list, `2`, is assigned to `i` and the `echo` command re-executed, resulting in the display of `2` at the terminal. The third word in the list, `3`, is assigned to `i` the third time through the loop and the `echo` command executed. This results in `3` being displayed at the terminal. At that point, no more words are left in the list, so execution of the `for` command is then complete, and the shell displays your command prompt to let you know it's done.

Recall the `run` program from [Chapter 7](#), "Passing Arguments," that enabled you to run a file through `tbl`, `nroff`, and `lp`:

```
$ cat run
tbl $1 | nroff -mm -Tlp | lp
$
```

If you wanted to run the files `memo1` through `memo4` through this program, you could type the following at the terminal:

```
$ for file in memo1 memo2 memo3 memo4
```

```
> do
>     run $file
> done
request id is laser1-33 (standard input)
request id is laser1-34 (standard input)
request id is laser1-35 (standard input)
request id is laser1-36 (standard input)
$
```

The four words `memo1`, `memo2`, `memo3`, and `memo4` will be assigned to the variable `file` in order, and the `run` program will be executed with the value of this variable as the argument. Execution will be just as if you typed in the four commands:

```
$ run memo1
request id is laser1-33 (standard input)
$ run memo2
request id is laser1-34 (standard input)
$ run memo3
request id is laser1-35 (standard input)
$ run memo4
request id is laser1-36 (standard input)
$
```

Incidentally, the shell permits filename substitution in the list of words in the `for`, meaning that the previous loop could have also been written this way:

```
for file in memo[1-4]
do
```

```
run $file
```

```
done
```

And if you wanted to run all the files in your current directory through `run`, you could type

```
for file in *
```

```
do
```

```
run $file
```

```
done
```

If the file `filelist` contains a list of the files that you want to run through `run`, you can type

```
files=$(cat filelist)
```

```
for file in $files
```

```
do
```

```
run $file
```

```
done
```

to run each of the files, or, more succinctly,

```
for file in $(cat filelist)
```

```
do
```

```
run $file
```

```
done
```

If you found that you were using the `run` program often to process several files at once, you could go

inside the `run` program and modify it to allow any number of files to be passed as arguments to the program.

```
$ cat run
#
# process files through nroff -- version 2
#
for file in $*
do
    tbl $file | nroff -rom -Tlp | lp
done
$
```

Recall that the special shell variable `$*` stands for *all* the arguments typed on the command line. So if you executed the new version of `run` by typing

```
run memo1 memo2 memo3 memo4
```

the `$*` in the `for`'s list would be replaced by the four arguments `memo1`, `memo2`, `memo3`, and `memo4`. Of course, you could also type

```
run memo[1-4]
```

to achieve the same results.

## The `$@` Variable

While we're on the subject of `$*`, let's look at it in a bit more detail. We'll write a program called `args` that displays all the arguments typed on the command line, one per line.

```
$ cat args
echo Number of arguments passed is $#

for arg in $*
do
    echo $arg
done

$
```

Now to try it:

```
$ args a b c
Number of arguments passed is 3
a
b
c

$ args 'a b' c
Number of arguments passed is 2
a
b
c

$
```

In the second case, even though `a b` was passed as a single argument to `args`, the `$*` in the `for` command was replaced by the shell with `a b c`, which is three words. Thus the loop was executed three times.

Whereas the shell replaces the value of `$*` with `$1, $2, ...`, if you instead use the special shell variable `"$@"` it will be replaced with `"$1", "$2", ...`. The double quotes are necessary around `$@`



because without them this variable behaves just like `$*`.

Go back to the `args` program and replace the `$*` with `"$@"`:

```
$ cat args
echo Number of arguments passed is $#
```

```
for arg in "$@"
do
    echo $arg
done
$
```

Now try it:

```
$ args a b c
Number of arguments passed is 3
a
b
c
```

```
$ args 'a b' c
Number of arguments passed is 2
a b
c
```

```
$ args Try it with no arguments
Number of arguments passed is 0
$
```

In the last case, no arguments were passed to the program. So the variable "\$@" was replaced by *nothing*. The net result is that the body of the loop was not executed at all.

## The `for` Without the List

A special notation is recognized by the shell when writing `for` commands. If you write

```
for var
do
    command
    command
    ...
done
```

(note the absence of the `in`), the shell automatically sequences through all the arguments typed on the command line, just as if you had written

```
for var in "$@"
do
    command
    command
    ...
done
```

Here's the third and last version of the `args` program:

```
$ cat args
echo Number of arguments passed is $#
```

```
for arg
do
    echo $arg
done

$ args a b c
Number of arguments passed is 3
a
b
c

$ args 'a b' c
Number of arguments passed is 2
a b
c
$
```

## The `while` Command

The second type of looping command to be described in this chapter is the `while`. The format of this command is

```
while commandt
do
    command
    command
    ...
done
```

*command<sub>i</sub>* is executed and its exit status tested. If it's zero, the commands enclosed between the **do** and **done** are executed. Then *command<sub>i</sub>* is executed again and its exit status tested. If it's zero, the commands enclosed between the **do** and **done** are once again executed. This process continues until *command<sub>i</sub>* returns a nonzero exit status. At that point, execution of the loop is terminated. Execution then proceeds with the command that follows the **done**.

Note that the commands between the **do** and **done** might never be executed if *command<sub>i</sub>* returns a nonzero exit status the first time it's executed.

Here's a program called **twhile** that simply counts to 5:

```
$ cat twhile
```

```
i=1
```

```
while [ "$i" -le 5 ]
```

```
do
```

```
    echo $i
```

```
    i=$((i + 1))
```

```
done
```

```
$ twhile Run it
```

```
1
```

```
2
```

```
3
```

```
4
```

```
5
```

```
$
```

The variable **i** is used as the counting variable and is initially set equal to 1. Then the **while** loop is entered. It continues execution as long as **i** is less than or equal to 5. Inside the loop, the value of **i** is displayed at the terminal. Then it is incremented by one.

The **while** loop is often used in conjunction with the **shift** command to process a variable number of arguments typed on the command line. The next program, called **prargs**, prints each of the

command-line arguments one per line.

```
$ cat prargs
#
# Print command line arguments one per line
#

while [ "$#" -ne 0 ]
do
    echo "$1"
    shift
done

$ prargs a b c
a
b
c

$ prargs 'a b' c
a b
c

$ prargs *
addresses
intro
lotsaspaces
names
nu
numbers
```

phonebook

stat

\$ **prargs**      *No arguments*

\$

While the number of arguments is not equal to zero, the value of `$1` is displayed and then a `shift` executed. Recall that this shifts down the variables (that is, `$2` to `$1`, `$3` to `$2`, and so on) and also decrements `$#`. When the last argument has been displayed and shifted out, `$#` will equal zero, at which point execution of the `while` will be terminated. Note that if no arguments are given to `prargs` (as was done in the last case), the `echo` and `shift` are never executed because `$#` is equal to zero as soon as the loop is entered.

Team LiB

◀ PREVIOUS

NEXT ▶

## The `until` Command

The `while` command continues execution as long as the command listed after the `while` returns a zero exit status. The `until` command is similar to the `while`, only it continues execution as long as the command that follows the `until` returns a *nonzero* exit status. As soon as a zero exit status is returned, the loop is terminated. Here is the general format of the `until`:

```
until commandt
do
    command
    command
    ...
done
```

Like the `while`, the commands between the `do` and `done` might never be executed if *command*<sub>t</sub> returns a zero exit status the first time it's executed.

The `until` command is useful for writing programs that wait for a particular event to occur. For example, suppose that you want to see whether `sandy` is logged on because you have to give her something important. You could send her electronic mail, but you know that she usually doesn't get around to reading her mail until late in the day. One approach is to use the `on` program from [Chapter 8](#), "Decisions, Decisions," to see whether `sandy`'s logged on:

```
$ on sandy
sandy is not logged on
$
```

You could execute this program periodically throughout the day, until `sandy` eventually logs on, or you could write your own program to continually check until she does. Let's call the program `mon` and have it take a single argument: the name of the user you want to monitor. Instead of having the program continually check for that user logging on, we'll have it check only once every minute. To do this, you have to know about a command called `sleep` that suspends execution of a program for a specified number of seconds. So the Unix command (this isn't a shell built-in)

```
sleep n
```

suspends execution of the program for *n* seconds. At the end of that interval, the program resumes execution where it left off—with the command that immediately follows the `sleep`.

```
$ cat mon

#

# Wait until a specified user logs on

#

if [ "$#" -ne 1 ]

then

    echo "Usage: mon user"

    exit 1

fi

user="$1"

#

# Check every minute for user logging on

#

until who | grep "^$user " > /dev/null

do

    sleep 60

done
```



```
#  
# When we reach this point, the user has logged on  
#  
echo "$user has logged on"  
$
```

After checking that one argument was provided, the program assigns `$1` to `user`. Then an `until` loop is entered. This loop will be executed until the exit status returned by `grep` is zero; that is, until the specified user logs on. As long as the user isn't logged on, the body of the loop—the `sleep` command—is executed. This command suspends execution of the program for one minute (60 seconds). At the end of the minute, the pipeline listed after the `until` is re-executed and the process repeated.

When the `until` loop is exited—signaling that the monitored user has logged on—a message is displayed at the terminal to that effect.

```
$ mon sandy Time passes  
sandy has logged on  
$
```

Using the program as shown here is not very practical because it ties up your terminal until `sandy` logs on. A better idea is to run `mon` in the background so that you can use your terminal for other work:

```
$ mon sandy & Run it in the background  
[1] 4392 Job number and process id  
$ nroff newmemo Do other work  
...  
sandy has logged on Happens sometime later
```

So now you can do other work and the `mon` program continues executing in the background until `sandy` logs on, or until you log off the system. [\[1\]](#)

<sup>[1]</sup> *All your processes are automatically terminated when you log off the system. If you want a program to continue executing after you've logged off, you can run it with the `nohup` command, or schedule it to run with `at` or from the `cron`. Consult your Unix User's Manual for more details.*

Because `mon` only checks once per minute for the user's logging on, it won't hog the system's resources while it's running (an important consideration when submitting programs to the background for execution).

Unfortunately, after the specified `user` logs on, there's a chance you might miss that one-line message (you may be `cat`ing a file and might not even notice it come and go right off your screen). Also if you're editing a file with a screen editor such as `vi` when the message comes, it may turn your screen into a mess, and you still might miss the message. A better alternative to writing the message to the terminal might be to mail it instead. Actually, you can let the user select his or her preference by adding an option to the program that, if selected, indicates that the message is to be mailed. If the option is not selected, the message can be displayed at the terminal.

In the version of `mon` that follows, a `-m` option has been added for this purpose:

```
$ cat mon

#

# Wait until a specified user logs on -- version 2

#

if [ "$1" = -m ]

then

    mailopt=TRUE

    shift

else

    mailopt=FALSE

fi

if [ "$#" -eq 0 -o "$#" -gt 1 ]

then
```

```
    echo "Usage: mon [-m] user"

    echo "    -m means to be informed by mail"

    exit 1

fi

user="$1"

#

# Check every minute for user logging on

#

until who | grep "^$user " > /dev/null

do

    sleep 60

done

#

# When we reach this point, the user has logged on

#

if [ "$mailopt" = FALSE ]

then

    echo "$user has logged on"

else

    echo "$user has logged on" | mail steve

fi
```

```
$
```

The first test checks to see whether the `-m` option was supplied. If it was, the characters `TRUE` are assigned to the variable `mailopt`, and `shift` is executed to "shift out" the first argument (moving the name of the user to be monitored to `$1` and decrementing `$#`). If the `-m` option wasn't specified as the first argument, the characters `FALSE` are assigned to `mailopt`.

Execution then proceeds as in the previous version. However, this time when the loop is exited a test is made to see whether the `-m` option was selected. If it wasn't, the message is written to standard output; otherwise, it's mailed to `steve`.

```
$ mon sandy -m
```

```
Usage: mon [-m] user
```

```
    -m means to be informed by mail
```

```
$ mon -m sandy &
```

```
[1] 5435
```

```
$ vi newmemo          Work continues
```

```
...
```

```
you have mail
```

```
$ mail
```

```
From steve Wed Aug 28 17:44:46 EDT 2002
```

```
sandy has logged on
```

```
?d
```

```
$
```

Of course, we could have written `mon` to accept the `-m` option as either the first or second argument, but that goes against the recommended command syntax standard, which specifies that all options should precede any other types of arguments on the command line.[\[2\]](#)

[2] The command syntax standard consists of a set of rules as outlined in the Utility Argument Syntax section of the POSIX standard.

Also note that the old version of `mon` could have been executed as follows:

```
$ mon sandy | mail steve &
```

```
[1] 5522
```

```
$
```

to achieve the same net result as adding the `-m` option.

Two last points before leaving the discussion of `mon`: First, you'll probably always want to run this program in the background. It would be nice if `mon` itself could take care of that. Later you'll see how to do it.

Second, the program always sends mail to `steve`; not very nice if someone else wants to run it. A better way is to determine the user running the program and then send him or her the mail if the `-m` option is selected. But how do you do that? One way is to execute the `who` command with the `am i` options and get the user name that comes back. This tells you who's logged on to the terminal that the program was run from. You can then use `cut` to extract the username from `who`'s output and use that name as the recipient of the mail. All this can be done in the last `if` command of `mon` if it's changed to read as shown:

```
if [ "$#" -eq 1 ]
then
    echo "$user has logged on"
else
    runner=$(who am i | cut -c1-8)
    echo "$user has logged on" | mail $runner
fi
```

Now the program can be run by anyone, and the mail will be properly sent.

# More on Loops

## Breaking Out of a Loop

Sometimes you may want to make an immediate exit from a loop. To just exit from the loop (and not from the program), you can use the `break` command, whose format is simply

```
break
```

When the `break` is executed, control is sent immediately out of the loop, where execution then continues as normal with the command that follows the `done`.

The Unix command `true` serves no purpose but to return an exit status of zero. The command `false` also does nothing but return a nonzero exit status. If you write

```
while true
do
    ...
done
```

the `while` loop will theoretically be executed forever because `true` always returns a zero exit status. By the way, the `:` command also does nothing but return a zero exit status, so an "infinite" loop can also be set up with

```
while :
do
    ...
done
```

Because `false` always returns a nonzero exit status, the loop

```
until false
do
    ...
done
```

will theoretically execute forever.

The `break` command is often used to exit from these sorts of infinite loops, usually when some error condition or the end of processing is detected:

```
while true
do
    cmd=$(getcmd)

    if [ "$cmd" = quit ]
    then
        break
    else
        processcmd "$cmd"
    fi
done
```

Here the `while` loop will continue to execute the `getcmd` and `processcmd` programs until `cmd` is equal to `quit`. At that point, the `break` command will be executed, thus causing the loop to be exited.

If the `break` command is used in the form

```
break n
```

the *n* innermost loops are immediately exited, so in

```
for file
do
    ...
    while [ "$count" -lt 10 ]
    do
        ...
        if [ -n "$error" ]
        then
            break 2
        fi
        ...
    done
    ...
done
```

both the `while` *and* the `for` loops will be exited if `error` is nonnull.

## Skipping the Remaining Commands in a Loop

The `continue` command is similar to `break`, only it doesn't cause the loop to be exited, merely the remaining commands in the loop to be skipped. Execution of the loop then continues as normal. Like the `break`, an optional number can follow the `continue`, so

```
continue n
```



causes the commands in the innermost `/`loops to be skipped; but execution of the loops then continues as normal.

```
for file
do
    if [ ! -e "$file" ]
    then
        echo "$file not found!"
        continue
    fi

    #
    # Process the file
    #

    ...
done
```

Each value of `file` is checked to make sure that the file exists. If it doesn't, a message is printed, and further processing of the file is skipped. Execution of the loop then continues with the next value in the list. Note that the preceding example is equivalent to writing

```
for file
do
    if [ ! -e "$file" ]
    then
        echo "$file not found!"
    else
```

```
        #
        # Process the file
        #
        ...
    fi
done
```

## Executing a Loop in the Background

An entire loop can be sent to the background for execution simply by placing an ampersand after the `done`:

```
$ for file in memo[1-4]
> do
>     run $file
> done &                               Send it to the background
[1] 9932
$
request id is laser1-85 (standard input)
request id is laser1-87 (standard input)
request id is laser1-88 (standard input)
request id is laser1-92 (standard input)
```

## I/O Redirection on a Loop

You can also perform I/O redirection on the entire loop. Input redirected into the loop applies to all commands in the loop that read their data from standard input. Output redirected from the loop to a file applies to all commands in the loop that write to standard output:

```
$ for i in 1 2 3 4
> do
>     echo $i
> done > loopout           Redirect loop's output to loopout
$ cat loopout
1
2
3
4
$
```

You can override redirection of the entire loop's input or output by explicitly redirecting the input and/or output of commands inside the loop. To force input or output of a command to come from or go to the terminal, use the fact that `/dev/tty` always refers to your terminal. In the following loop, the `echo` command's output is explicitly redirected to the terminal to override the global output redirection applied to the loop:

```
for file
do
    echo "Processing file $file" > /dev/tty
    ...
done > output
```

`echo`'s output is redirected to the terminal while the rest goes to the file `output`.

Naturally, you can also redirect the standard error output from a loop, simply by tacking on a `2> file` after the `done`:

```
while [ "$endofdata" -ne TRUE ]
```

```
do
    ...
done 2> errors
```

Here output from all commands in the loop writing to standard error will be redirected to the file `errors`.

## Piping Data Into and Out of a Loop

A command's output can be piped into a loop, and the entire output from a loop can be piped into another command in the expected manner. Here's a highly manufactured example of the output from a `for` command piped into `wc`:

```
$ for i in 1 2 3 4
> do
>     echo $i
> done | wc -l
    4
$
```

## Typing a Loop on One Line

If you find yourself frequently executing loops directly at the terminal, you'll want to use the following shorthand notation to type the entire loop on a single line: Put a semicolon after the last item in the list and one after each command in the loop. Don't put a semicolon after the `do`.

Following these rules, the loop

```
for i in 1 2 3 4
do
    echo $i
```

```
done
```

becomes

```
for i in 1 2 3 4; do echo $i; done
```

And you can type it in directly this way:

```
$ for i in 1 2 3 4; do echo $i; done
```

```
1
```

```
2
```

```
3
```

```
4
```

```
$
```

The same rules apply to `while` and `until` loops.

`if` commands can also be typed on the same line using a similar format:

```
$ if [ 1 = 1 ]; then echo yes; fi
```

```
yes
```

```
$ if [ 1 = 2 ]; then echo yes; else echo no; fi
```

```
no
```

```
$
```

Note that no semicolons appear after the `then` and the `else`.

## The `getopts` Command

Let's extend our `mon` program further. We'll add a `-t` option to it that specifies the time interval, in seconds, to perform the check. Now our `mon` program takes both `-m` and `-t` options. We'll allow it to take these options in any order on the command line, provided that if they are used, they appear before the name of the user that we're monitoring. So valid `mon` command lines look like this:

```
mon ann
```

```
mon -m ann
```

```
mon -t 600 ann
```

```
mon -m -t 600 ann
```

```
mon -t 600 -m ann
```

and invalid ones look like this:

```
mon                               Missing user name
mon -t600 ann                     Need a space after -t
mon ann -m                         Options must appear first
mon -t ann                         Missing argument after -t
```

If you start writing the code to allow this sort of flexibility on the command line, you will soon discover that it can start to get a bit complex. Luckily, the shell provides a built-in command called `getopts` that exists for the express purpose of processing command-line arguments. The general format of the command is

```
getopts options variable
```

The `getopts` command is designed to be executed inside a loop. Each time through the loop, `getopts` examines the next command line argument and determines whether it is a valid option. This

determination is made by checking to see whether the argument begins with a minus sign and is followed by any single letter contained inside *options*. If it does, `getopts` stores the matching option letter inside the specified *variable* and returns a zero exit status.

If the letter that follows the minus sign is not listed in *options*, `getopts` stores a question mark inside *variable* before returning with a zero exit status. It also writes an error message to standard error.

If no more arguments are left on the command line or if the next argument doesn't begin with a minus sign, `getopts` returns a nonzero exit status.

Suppose that you want `getopts` to recognize the options `-a`, `-i`, and `-r` for a command called `foo`. Your `getopts` call might look like this:

```
getopts air option
```

Here the first argument—`air`—specifies the three acceptable options to the command, and `option` specifies the variable that `getopts` will use as previously described.

The `getopts` command permits options to be "stacked" together on the command line. This is done by following a single minus sign with one or more consecutive options letters. For example, our `foo` command can be executed like this:

```
foo -a -r -i
```

or like this:

```
foo -ari
```

using this stacking feature.

The `getopts` command also handles the case where an option must be followed by an argument. For example, the new `-t` option to be added to the `mon` command requires a following argument. To handle options that take arguments, `getopts` requires that at least one whitespace character separate the option from the argument. Furthermore, such options cannot be stacked.

To indicate to `getopts` that an option takes a following argument, you write a colon character after the option letter on the `getopts` command line. So our `mon` program, which takes `-m` and `-t` options, should call `getopts` like this:

```
getopts mt: option
```

If `getopts` doesn't find an argument after an option that requires one, it stores a question mark inside the specified variable and writes an error message to standard error. Otherwise, it stores the actual argument inside a special variable called `OPTARG`.

One final note about `getopts`: Another special variable called `OPTIND` is used by the command. This variable is initially set to one and is updated each time `getopts` returns to reflect the number of the *next* command-line argument to be processed.

Here is the third version of `mon` that uses the `getopts` command to process the command-line arguments. It also incorporates the previously noted change to send mail to the user running the program.

```
$ cat mon

#

# Wait until a specified user logs on -- version 3

#

# Set up default values

mailopt=FALSE

interval=60

# process command options

while getopts mt: option
do
    case "$option"
    in
        m) mailopt=TRUE;;
```



```
t) interval=$OPTARG;;

\?) echo "Usage: mon [-m] [-t n] user"

    echo "    -m means to be informed by mail"

    echo "    -t means check every n secs."

    exit 1;;

esac

done

# Make sure a user name was specified

if [ "$OPTARG" -gt "$#" ]

then

    echo "Missing user name!"

    exit 2

fi

shiftcount=$((OPTARG - 1))

shift $shiftcount

user=$1

#

# Check for user logging on

#

until who | grep "^$user " > /dev/null

do
```

```
        sleep $interval
done

#
# When we reach this point, the user has logged on
#

if [ "$mailopt" = FALSE]
then
    echo "$user has logged on"
else
    runner=$(who am i | cut -c1-8)
    echo "$user has logged on" | mail $runner
fi
```

```
$ mon -m
```

```
Missing user name!
```

```
$ mon -x fred
```

```
Illegal option
```

```
mon: illegal option -- x
```

```
Usage: mon [-m] [-t n] user
```

```
    -m means to be informed by mail
```

```
    -t means check every n secs.
```

```
$ mon -m -t 600 ann &
```

```
Check every 10 min. for ann
```

```
[1] 5792
```

```
$
```

When the line

```
mon -m -t 600 ann &
```

is executed, the following occurs inside the `while` loop in `mon`: `getopts` is executed, and it stores the character `m` inside the variable `option`, sets `OPTIND` to two, and returns a zero exit status. The `case` command is then executed to determine what was stored inside `option`. A match on the character `m` indicates that the "send mail" option was selected, so `mailtopt` is set to `TRUE`. (Note that the `?` inside the `case` is quoted. This is to remove its special meaning as a pattern-matching character from the shell.)

The second time `getopts` is executed, `getopts` stores the character `t` inside `option`, stores the next command-line argument (`600`) inside `OPTARG`, sets `OPTIND` to three, and returns a zero exit status. The `case` command then matches the character `t` stored inside `option`. The code associated with that case copies the value of `600` that was stored in `OPTARG` into the variable `interval`.

The third time `getopts` is executed, `getopts` returns a nonzero exit status, indicating the end of options. The program then checks the value of `OPTIND` against `$#` to make sure that the username was typed on the command line. If `OPTIND` is greater than `$#`, then no more arguments remain on the command line and the user forgot the username argument. Otherwise, the `shift` command is executed to move the username argument into `$1`. The actual number of places to shift is one less than the value of `OPTIND`.

The rest of the `mon` program remains as before; the only change is the use of the `interval` variable to specify the number of seconds to sleep.

## Exercises

- 1: Modify the `prargs` program to precede each argument by its number. So typing

```
prargs a 'b c' d
```

should give the following output:

```
1: a
```

```
2: b c
```

```
3: d
```

- 2: Modify the `mon` program to also print the `tty` number that the user logs on to. That is, the output should say

```
sandy logged onto tty13
```

if `sandy` logs on to `tty13`.

- 3: Add a `-f` option to `mon` to have it periodically check for the existence of a file (ordinary file or directory) instead of for a user logging on. So typing

```
mon -f /usr/spool/uucppublic/steve/newmemo &
```

should cause `mon` to periodically check for the existence of the indicated file and inform you when it does (by displaying a message or by mail if the `-m` option is also selected).

- 4: Add a `-n` option to `mon` that inverts the monitoring function. So

```
mon -n sandy
```

checks for `sandy` logging off the system, and

```
mon -n -f /tmp/dataout &
```

periodically checks for the removal of the specified file.

- 5: Write a program called `collect` that runs in the background and counts the number of users logged in at the end of each interval and also the number of processes run during that interval. Allow the interval to be specified with a `-t` option (see the previous exercise), with the default 10 minutes. Use the fact that the special shell variable `#!` is set to the process number of the last command executed in the background and that

```
: &
```

runs a null command in the background. Also make sure that the program correctly handles the case where the process number loops back around to 1 after the maximum is reached.

So

```
collect -t 900 > stats &
```

should start up `collect` to gather the desired statistics every 15 minutes and write them into the file `stats`.

- 6: Write a shell program called `wgrep` that searches a file for a given pattern, just as `grep` does. For each line in the file that matches, print a "window" around the matching line. That is, print the line preceding the match, the matching line, and the line following the match. Be sure to properly handle the special cases where the pattern matches the first line of the file and where the pattern matches the last line of the file.
- 7: Modify `wgrep` to take an optional `-w` option that specifies the window size; so

```
wgrep -w 3 UNIX text
```

should print three lines before and after each line from `text` that contains the pattern `UNIX`.

- 8: Modify `wgrep` to take a variable number of filenames as arguments. Precede each output line with the name of the file in which the match occurs (as `grep` does).

Team LiB

◀ PREVIOUS

NEXT ▶

# Chapter 10. Reading and Printing Data

## IN THIS CHAPTER

- [The `read` Command](#)
- [The `printf` Command](#)
- [Exercises](#)

In this chapter you'll learn how to read data from the terminal or from a file using the `read` command and how to print formatted data to standard output using the `printf` command.

## The `read` Command

The general format of the `read` command is

```
read variables
```

When this command is executed, the shell reads a line from standard input and assigns the first word read to the first variable listed in *variables*, the second word read to the second variable, and so on. If there are more words on the line than there are variables listed, the excess words get assigned to the last variable. So for example, the command

```
read x y
```

reads a line from standard input, storing the first word read in the variable `x`, and the remainder of the line in the variable `y`. It follows from this that the command

```
read text
```

reads and stores an entire line into the shell variable `text`.

## A Program to Copy Files

Let's put the `read` command to work. We'll write a simplified version of the `cp` command that will be a bit more user friendly than the standard Unix one. We'll call it `mycp`, and we'll have it take two arguments: the source file and the destination file. If the destination file already exists, we'll tell the user and then ask him (or her) if he wants to proceed with the copy. If the answer is "yes," we'll go ahead with it; otherwise, we won't.

```
$ cat mycp
```

```
#
```

```
# Copy a file
```



```
#

if [ "$#" -ne 2 ]
then
    echo "Usage: mycp from to"
    exit 1
fi

from="$1"
to="$2"

#
# See if the destination file already exists
#

if [ -e "$to" ]
then
    echo "$to already exists; overwrite (yes/no)?"
    read answer

    if [ "$answer" != yes ]
    then
        echo "Copy not performed"
        exit 0
    fi
fi
```

```
#  
# Either destination doesn't exist or "yes" was typed  
#  
  
cp $from $to      # proceed with the copy  
  
$
```

And now for the test:

```
$ ls                      What files are around?  
  
addresses  
  
intro  
  
lotsaspaces  
  
mycp  
  
names  
  
nu  
  
numbers  
  
phonebook  
  
stat  
  
$ mycp                    No arguments  
  
Usage: mycp from to  
  
$ mycp names names2      Make a copy of names  
  
$ ls -l names*           Did it work?  
  
-rw-r--r--  1 steve  steve    43 Jul  20 11:12 names  
-rw-r--r--  1 steve  steve    43 Jul  21 14:16 names2
```

```
$ mycp names numbers          Try to overwrite an existing file
```

```
numbers already exists; overwrite (yes/no)?
```

```
no
```

```
Copy not performed
```

```
$
```

To complete the test cases, try answering yes and ensuring that the program proceeds with the copy.

There are a few things worthy of mention with the `mycp` program. First, if the file already exists, the `echo` command that prompts for the yes/no response is executed. The `read` command that follows causes the shell to wait for you to type something in. Note that the shell does not prompt you when it's waiting for you to enter data; it's up to you to add your own prompt message to the program.

The data that is typed is stored in the variable `answer` and is then tested against the characters "yes" to determine whether the copy is to proceed. The quotes around `answer` in the test

```
[ "$answer" != yes ]
```

are necessary in case the user just presses the Enter key without typing any data. In that case, the shell would store a null value in `answer`, and `test` would issue an error message if the quotes were omitted.

## Special `echo` Escape Characters

A slight annoyance with `mycp` is that after the `echo` command is executed to alert the user that the file already exists, the response that is typed by the user appears on the next line. This happens because the `echo` command always automatically displays a terminating newline character after the last argument.

This can be suppressed if the last two characters given to `echo` are the special *escape* characters `\c`. This tells `echo` to leave the cursor right where it is after displaying the last argument and not to go to the next line. So if you changed the `echo` command in `mycp` to read like this:

```
echo "$to already exists; overwrite (yes/no)? \c"
```

the user's input would be typed right after the message on the same line. Bear in mind that the `\c` is interpreted by `echo` and not by the shell, meaning that it must be quoted so that the backslash

makes it to `echo`.

`echo` interprets other special characters. These must each be preceded by a backslash. They're summarized in [Table 10.1](#).

Table 10.1. `echo` Escape Characters

Character	Prints
<code>\b</code>	Backspace
<code>\c</code>	The line without a terminating newline
<code>\f</code>	Formfeed
<code>\n</code>	Newline
<code>\r</code>	Carriage return
<code>\t</code>	Tab character
<code>\\</code>	Backslash character
<code>\0mmm</code>	The character whose ASCII value is <i>mmm</i> , where <i>mmm</i> is a one- to three-digit octal number

## An Improved Version of `mycp`

Suppose that you have a program called `prog1` in your current directory and you want to copy it into your `bin` directory directly below. Take another look at the `mycp` program and determine what happens if you type in

```
mycp prog1 bin
```

The `-e` test on `bin` will succeed (because `-e` tests for existence of a file), and `mycp` will display the "already exists" message and wait for a yes/no answer.

If the second argument is a directory, `mycp` should check to see whether the `from` file exists *inside* this directory. The next version of `mycp` performs this check. It also has the modified `echo` command that includes the `\c` to suppress the terminating newline.

```
$ cat mycp
```

```
#
```

```
# Copy a file -- version 2
```

```
#

if [ "$#" -ne 2 ]
then
    echo "Usage: mycp from to"
    exit 1
fi

from="$1"
to="$2"

#
# See if destination file is a directory
#

if [ -d "$to" ]
then
    to="$to/${basename $from}"
fi

#
# See if the destination file already exists
#

if [ -e "$to" ]
then
```

```

    echo "$to already exists; overwrite (yes/no)? \c"
    read answer

    if [ "$answer" != yes ]
    then
        echo "Copy not performed"
        exit 0
    fi
fi

#
# Either destination doesn't exist or 'yes' was typed
#

cp $from $to      # proceed with the copy

$

```

If the destination file is a directory, the program changes the variable `to` to more precisely identify the file inside the directory as `$to/${basename $from}`. This ensures that the following test on the existence of the ordinary file `$to` will be done on the file in the directory, not on the directory itself as the previous version of `mycp` did. The `basename` command gives the base filename of its argument (for example, `basename /usr/bin/troff` gives `troff`; `basename troff` gives `troff`). This ensures that the copy is made to the correct place. (For example, if `mycp /tmp/data bin` is typed, where `bin` is a directory, you want to copy `/tmp/data` into `bin/data` and not into `bin/tmp/data`.)

Here's some sample output. Note the effect of the `\c` escape characters.

```

$ ls                               Check out current directory

bin

progl

$ ls bin                            Look inside bin

```

```
lu
nu
prog1
$ mycp prog1 prog2    Simple case
$ mycp prog1 bin      Copy into directory
bin/prog1 already exists; overwrite (yes/no)? yes
$
```

## A Final Version of `mycp`

The last modification to `mycp` makes the program virtually equivalent to the standard Unix `cp` command by allowing a variable number of arguments. Recall that any number of files can precede the name of a directory, as in

```
cp prog1 prog2 greetings bin
```

To modify `mycp` to accept any number of files, you can use this approach:

1. Get each argument but the last from the command line and store it in the shell variable `filelist`.
2. Store the last argument in the variable `to`.
3. If `$to` is not a directory, there must be exactly two arguments.
4. For each file in `$filelist`, check whether the file already exists. If it does, ask the user whether the file should be overwritten. If the answer is "yes," or if the file doesn't already exist, add the file to the variable `copylist`.
5. If `copylist` is nonnull, copy the files in it to `$to`.

If this algorithm seems a bit fuzzy, perhaps the program, followed by a detailed explanation, will help clear things up. Note the modified command usage message.

```
$ cat mycp
```

```
#  
  
# Copy a file -- final version  
  
#  
  
numargs=$#          # save this for later use  
  
filelist=  
  
copylist=  
  
#  
  
# Process the arguments, storing all but the last in filelist  
  
#  
  
while [ "$#" -gt 1 ]  
do  
    filelist="$filelist $1"  
    shift  
  
done  
  
to="$1"  
  
#  
  
# If less than two args, or if more than two args and last arg  
# is not a directory, then issue an error message  
  
#  
  
if [ "$numargs" -lt 2 -o "$numargs" -gt 2 -a ! -d "$to" ]
```



```
then

    echo "Usage: mycp file1 file2"

    echo "      mycp file(s) dir"

    exit 1

fi

#

# Sequence through each file in filelist

#

for from in $filelist

do

    #

    # See if destination file is a directory

    #

    if [ -d "$to" ]

    then

        tofile="$to/${basename $from}"

    else

        tofile="$to"

    fi

    #

    # Add file to copylist if file doesn't already exist

    # or if user says it's okay to overwrite
```

```
#

if [ -e "$tofile" ]
then
    echo "$tofile already exists; overwrite (yes/no)? \c"
    read answer

    if [ "$answer" = yes ]
    then
        copylist="$copylist $from"
    fi
else
    copylist="$copylist $from"
fi
done

#
# Now do the copy -- first make sure there's something to copy
#
if [ -n "$copylist" ]
then
    cp $copylist $to      # proceed with the copy
fi
$
```

Let's look at some sample output before getting into the explanation.

`$ ls` *See what's around*

bin

lu

names

prog1

prog2

`$ ls bin` *And what's in bin?*

lu

nu

prog1

`$ mycp` *No arguments*

Usage: mycp file1 file2

mycp file(s) dir

`$ mycp names prog1 prog2` *Last arg isn't a directory*

Usage: mycp file1 file2

mycp file(s) dir

`$ mycp names prog1 prog2 lu bin` *Legitimate use*

bin/prog1 already exists; overwrite (yes/no)? **yes**

bin/lu already exists; overwrite (yes/no)? **no**

`$ ls -l bin` *See what happened*

total 5

-rw-r--r-- 1 steve steve 543 Jul 19 14:10 lu

-rw-r--r-- 1 steve steve 949 Jul 21 17:11 names

-rw-r--r-- 1 steve steve 38 Jul 19 09:55 nu

-rw-r--r-- 1 steve steve 498 Jul 21 17:11 prog1

```
-rw-r--r--  1 steve  steve  498 Jul 21 17:11 prog2
```

```
$
```

In the last case, `prog1` was overwritten and `lu` wasn't, as per the user's request.

When the program starts execution, it saves the number of arguments in the variable `numargs`. This is done because it's changed later in the program by the `shift` command.

Next a loop is entered that is executed as long as the number of arguments is greater than one. The purpose of this loop is to get the last argument on the line. While doing this, the loop stashes away the first argument into the shell variable `filelist`, which contains a list of all the files to be copied. The statement

```
filelist="$filelist $1"
```

says to take the previous value of `filelist`, add on a space followed by the value of `$1`, and then store the result back into `filelist`. Then the `shift` command is executed to "move" all the arguments over by one. Eventually, `$#` will be equal to one, and the loop will be exited. At that point, `filelist` will contain a space-delimited list of all the files to be copied, and `$1` will contain the last argument, which is the destination file (or directory). To see how this works, consider execution of the `while` loop when the command is executed as

```
mycp names prog1 prog2 lu bin
```

[Figure 10.1](#) depicts the changing values of the variables through each iteration of the loop. The first line shows the state of the variables before the loop is entered.

Figure 10.1. Processing command-line arguments.

<code>\$#</code>	<code>\$1</code>	<code>\$2</code>	<code>\$3</code>	<code>\$4</code>	<code>\$5</code>	<code>filelist</code>
5	names	prog1	prog2	lu	bin	null
4	prog1	prog2	lu	bin		names
3	prog2	lu	bin			names prog1
2	lu	bin				names prog1 prog2
1	bin					names prog1 prog2 lu

After the loop is exited, the last argument contained in `$1` is stored in the variable `to`. Next, a test is

made to ensure that at least two arguments were typed on the command line and if more than two were typed, that the last argument is a directory. If either condition isn't satisfied, usage information is displayed to the user, and the program exits with a status of 1.

Following this, a `for` loop is entered for the purpose of individually examining each file in the list to see whether it already exists. If it does, the user is prompted as before. If the user wants to overwrite the file, or if the file doesn't already exist, the file is added to the shell variable `copylist`. The technique used here is the same used to accumulate the arguments inside `filelist`.

When the `for` loop is exited, `copylist` contains a list of all the files to be copied. This list can be null if each of the destination files exists and the user types "no" for each one. So a test is made to ensure `copylist` is nonnull, and if it is, the copy is performed.

Take some time to review the logic of the final version of `mycp`; it does a good job at illustrating many of the features you've learned so far in this book. Some exercises at the end of this chapter will help test your understanding of this program.

## A Menu-Driven Phone Program

One nice thing about the `read` command is that it enables you to write menu-driven shell programs. As an example, we'll return to our phone book programs `add`, `lu`, and `rem` and gather their execution together under one program, which we'll call `rolo` (for rolodex program). `rolo` will display a list of choices to the user and then execute the appropriate program depending on the selection. It will also prompt for the proper arguments to the program. Here, then, is the program:

```
$ cat rolo
#
# rolo - rolodex program to look up, add, and
#       remove people from the phone book
#
#
# Display menu
#
echo '
    Would you like to:
```

1. Look someone up
2. Add someone to the phone book
3. Remove someone from the phone book

Please select one of the above (1-3): \c'

```
#  
# Read and process selection  
#  
  
read choice  
  
echo  
  
case "$choice"  
  
in  
  
    1) echo "Enter name to look up: \c"  
        read name  
        lu "$name";;  
  
    2) echo "Enter name to be added: \c"  
        read name  
        echo "Enter number: \c"  
        read number  
        add "$name" "$number";;  
  
    3) echo "Enter name to be removed: \c"  
        read name  
        rem "$name";;
```

```
        *) echo "Bad choice";;
esac
$
```

A single `echo` command is used to display the menu at the terminal, taking advantage of the fact that the quotes preserve the embedded newline characters. Then the `read` command is executed to get the selection from the user and store it in the variable `choice`.

A `case` statement is next entered to determine what choice was made. If choice 1 was selected, the user wants to look up someone in the phone book. In that case, the user is asked to enter the name to be looked up, and the `lu` program is called, passing it the name typed in by the user as the argument. Note that the double quotes around `name` in

```
lu "$name"
```

are necessary to ensure that two or more words typed in by the user are handed over to `lu` as a single argument.

A similar sequence occurs if the user selects menu items 2 or 3.

The programs `lu`, `rem`, and `add` are from earlier chapters (`lu` is from page 137 `rem` from page 167, and `add` from page 138).

Here are some sample runs of `rolo`:

```
$ rolo
```

```
Would you like to:
```

1. Look someone up
2. Add someone to the phone book
3. Remove someone from the phone book

```
Please select one of the above (1-3): 2
```

Enter name to be added: **El Coyote**

Enter number: **212-555-3232**

\$ **rolo** *Try it again*

Would you like to:

1. Look someone up
2. Add someone to the phone book
3. Remove someone from the phone book

Please select one of the above (1-3): **1**

Enter name to look up: **Coyote**

El Coyote 212-555-3232

\$ **rolo** *Once again*

Would you like to:

1. Look someone up
2. Add someone to the phone book
3. Remove someone from the phone book

Please select one of the above (1-3): **4**

Bad choice

\$



When an invalid choice is entered, the program simply displays `Bad choice` and then terminates. A friendlier approach would be to reprompt the user until a proper choice is made. This can be done by enclosing the entire program inside an `until` loop that will be executed until a valid selection is made. To determine when a valid choice has been made, we can test a variable in the `until` that won't be assigned a value in the program until either 1, 2, or 3 is selected by the user.

Another change to make to `rolo` involves the way it will be used. Because the most common operation performed will be one of lookup, there will probably be a tendency on the part of the user to avoid typing `rolo`, then making selection 1, and then typing the name to be found when instead he or she can still type in

```
lu name
```

directly. Given all this, it might be a good idea to allow `rolo` to take command-line arguments. If any arguments are typed, `rolo` can assume that a lookup is being requested and just call `lu` directly. So if the user wants to perform a quick lookup, he or she can type `rolo` followed by the name. On the other hand, if the user wants to see the menu, typing just `rolo` causes the program to display its menu and prompt for a choice.

The preceding two changes (looping until a valid choice is selected and doing a quick lookup) were added to version 2 of `rolo` that is shown next.

```
$ cat rolo
#
# rolo - rolodex program to look up, add, and
#   remove people from the phone book -- version 2
#
#
# If arguments are supplied, then do a lookup
#
if [ "$#" -ne 0 ]
then
```

```
        lu "$@"
    exit
fi

validchoice=""          # set it null

#
# Loop until a valid selection is made
#

until [ -n "$validchoice" ]
do
    #
    # Display menu
    #

    echo '

Would you like to:

    1. Look someone up
    2. Add someone to the phone book
    3. Remove someone from the phone book

Please select one of the above (1-3): \c'
```

```
#
# Read and process selection
#
read choice
echo

case "$choice"
in
    1) echo "Enter name to look up: \c"
        read name
        lu "$name"
        validchoice=TRUE;;
    2) echo "Enter name to be added: \c"
        read name
        echo "Enter number: \c"
        read number
        add "$name" "$number"
        validchoice=TRUE;;
    3) echo "Enter name to be removed: \c"
        read name
        rem "$name"
        validchoice=TRUE;;
    *) echo "Bad choice";;
esac

done

$
```

If \$# is nonzero, `lu` is called directly with the arguments typed on the command line. Then the program exits. Otherwise, the `until` loop is executed until the variable `validchoice` is nonnull. The only way it can ever become nonnull is if the command

```
validchoice=TRUE
```

is executed inside the `case` on selection of either 1, 2, or 3. Otherwise, the program continues to loop until one of these three choices is made.

```
$ rolo Bill                Quick lookup
Billy Bach    201-555-7618

$ rolo                    Let's have the menu this time

Would you like to:

    1. Look someone up
    2. Add someone to the phone book
    3. Remove someone from the phone book

Please select one of the above (1-3): 4

Bad choice
```

```
Would you like to:

    1. Look someone up
    2. Add someone to the phone book
    3. Remove someone from the phone book
```

```
Please select one of the above (1-3): 0
```

```
Bad choice
```

```
Would you like to:
```

1. Look someone up
2. Add someone to the phone book
3. Remove someone from the phone book

```
Please select one of the above (1-3): 1
```

```
Enter name to look up: Tony
```

```
Tony Iannino      973-555-1295
```

```
$
```

## The \$\$ Variable and Temporary Files

If two or more people on your system use the `rolo` program at the same time, a potential problem may occur. Look at the `rem` program and see whether you can spot it. The problem occurs with the temporary file `/tmp/phonebook` that is used to create a new version of the phone book file.

```
grep -v "$name" phonebook > /tmp/phonebook
```

```
mv /tmp/phonebook phonebook
```

If more than one person uses `rolo` to remove an entry at the same time, there's a chance that the phone book file can get messed up because the same temporary file will be used by all `rolo` users.[\[1\]](#) Naturally, the chances of this happening (that is, the preceding two commands being executed at the

same time by more than one user) are rather small, but, nevertheless there still is that chance. Anyway, it brings up an important point when dealing with temporary files in general.

<sup>[1]</sup> *Actually, it depends on the users' default file creation mask (known as `umask`). If one person has created `/tmp/phonebook` and it's not writable by anyone else, the next person who comes along and tries to create it will get an error message from the shell. The net result is that the first user's file will get properly updated, and the second user's won't; neither file will get corrupted.*

When writing shell programs to be run by more than one person, make your temporary files unique. One way is to create the temporary file in the user's home directory, for example. Another way is to choose a temporary filename that will be unique for that particular process. To do this, you can use the special `$$` shell variable, which contains the process id number (PID) of the current process:

```
$ echo $$
```

```
4668
```

```
$ ps
```

```
PID  TTY  TIME  COMMAND
```

```
4668  co   0:09  sh
```

```
6470  co   0:03  ps
```

```
$
```

As you can see, `$$` is equal to the process id number of your login shell. Because each process on the Unix system is given a unique process id number, using the value of `$$` in the name of a file minimizes the possibility of another process using the same file. So you can replace the two lines from `rem` with these

```
grep -v "$name" phonebook > /tmp/phonebook$$
```

```
mv /tmp/phonebook$$ phonebook
```

to circumvent any potential problems. Each person running `rolo` will run it as a different process, so the temporary file used in each case will be different.

## The Exit Status from `read`

`read` always returns an exit status of zero unless an end of file condition is detected on the input. If the data is coming from the terminal, this means that `Ctrl+d` has been typed. If the data is coming

from a file, it means that there's no more data to read from the file.

Knowing about the exit status returned by `read` makes it easy to write a loop that will read any number of lines of data from a file or from the terminal. The next program, called `addi`, reads in lines containing pairs of integers. Each pair of numbers is summed, and the result written to standard output.

```
$ cat addi
#
# add pairs of integers on standard input
#
while read n1 n2
do
    echo $((n1 + n2))
done
$
```

The `while` loop is executed as long as the `read` command returns an exit status of zero; that is, as long as there's still data to be read. Inside the loop, the two values read from the line (presumably integers—no error checking is done here) are summed and the result written to standard output by `echo`.

```
$ addi
10 25
35
-5 12
7
123 3
126
```

*Ctrl+d*

\$

It goes without saying that standard input for `addi` can be redirected, as can standard output:

```
$ cat data
```

```
1234 7960
```

```
593 -595
```

```
395 304
```

```
3234 999
```

```
-394 -493
```

```
$ addi < data > sums
```

```
$ cat sums
```

```
9194
```

```
-2
```

```
699
```

```
4233
```

```
-887
```

```
$
```

The following program, called `number`, is a simplified version of the standard Unix `nl` command: It takes one or more files given as arguments and displays them preceded by line numbers. If no arguments are supplied, it uses standard input instead.

```
$ cat number
```

```
#
```

```
# Number lines from files given as argument or from
```



```
# standard input if none supplied
#

lineno=1

cat $* |
while read line
do
    echo "$lineno: $line"
    lineno=$((lineno + 1))
done
$
```

The variable `lineno`—the line number count—is initially set to `1`. Then the arguments typed to `number` are given to `cat` to be collectively written to standard output. If no arguments are supplied, `$*` will be null, and `cat` will be passed no arguments. This will cause it to read from standard input.

The output from `cat` is piped into the `while` loop. For each line read by `read`, the line is echoed at the terminal, preceded by the value of `lineno`, whose value is then incremented by one.

```
$ number phonebook
```

```
1: Alice Chebba      973-555-2015
2: Barbara Swingle  201-555-9257
3: Billy Bach       201-555-7618
4: El Coyote        212-555-3232
5: Liz Stachiw      212-555-2298
6: Susan Goldberg   201-555-7776
7: Teri Zak         201-555-6000
8: Tony Iannino     973-555-1295
```

```
$ who | number Try from standard input
1: root      console Jul 25 07:55
2: pat       tty03    Jul 25 09:26
3: steve    tty04    Jul 25 10:58
4: george   tty13    Jul 25 08:05
$
```

Note that `number` won't work too well for lines that contain backslashes or leading whitespace characters. The following example illustrates this point.

```
$ number
    Here are some backslashes: \ \*
1: Here are some backslashes: *
$
```

Leading whitespace characters are removed from any line that's read. The backslash characters are also interpreted by the shell when it reads the line. You can use the `-r` option to `read` to prevent it from interpreting the backslash character. If we change the

```
while read line
```

```
in number to
```

```
while read -r line
```

the output will look better:

```
$ number
```

Here are some backslashes: \ \\*

```
1: Here are some backslashes: \ \*
```

```
$
```

In [Chapter 12](#), "More on Parameters," you'll learn how to preserve the leading whitespace characters and also how to have some control over the parsing of the input data.

Team LiB

◀ PREVIOUS

NEXT ▶

## The `printf` Command

Although `echo` is adequate for displaying simple messages, sometimes you'll want to print *formatted* output: for example, lining up columns of data. Unix systems provide the `printf` command. Those of you familiar with the C programming language will notice many similarities.

The general format of the `printf` command is

```
printf "format" arg1 arg2 ...
```

where *format* is a string that describes how the remaining arguments are to be displayed. (Note that the format string is a single argument, so it's a good idea to get into the habit of enclosing it in quotes because it often contains whitespace.) Characters in the format string that are not preceded by a percent sign (%) are written to standard output. One or more characters preceded by a percent sign are called *conversion specifications* and tell `printf` how the corresponding argument should be displayed. So, for each percent sign in the format string there should be a corresponding argument, except for the special conversion specification `%%`, which causes a single percent sign to be displayed.

Here's a simple example of `printf`:

```
$ printf "This is a number: %d\n" 10
```

```
This is a number: 10
```

```
$
```

`printf` doesn't add a newline character to its output like `echo`; however, `printf` understands the same escape characters that `echo` does (refer to [Table 10.1](#) earlier in this chapter), so adding `\n` to the end of the format string causes the prompt to appear on the next line.

Although this is a simple case that could easily be handled by `echo`, it helps to illustrate how the conversion specification (`%d`) is interpreted by `printf`: When the format string is scanned by `printf`, it outputs each character in the string without modification until it sees the percent sign; then it reads the `d` and recognizes that the `%d` should be replaced by the next argument, which must be an integer number. After that argument (`10`) is sent to standard output, `printf` sees the `\n` and outputs a newline.

[Table 10.2](#) summarizes the different conversion specification characters.

Table 10.2. `printf` Conversion Specification Characters

Character	Use for Printing
<code>d</code>	Integers
<code>u</code>	Unsigned integers
<code>o</code>	Octal integers
<code>x</code>	Hexadecimal integers, using a-f
<code>X</code>	Hexadecimal integers, using A-F
<code>c</code>	Single characters
<code>s</code>	Literal strings
<code>b</code>	Strings containing backslash escape characters
<code>%</code>	Percent signs

The first five conversion specification characters are all used for displaying integers. `%d` displays signed integers, and `%u` displays unsigned integers; `%u` can also be used to display the positive representation of a negative number (note that the result is machine dependent). By default, integers displayed as octal or hexadecimal numbers do not have a leading `0` or `0x`, but we'll show you how to enable this later in this section.

Strings are printed using `%s` or `%b`. `%s` is used to print strings literally, without any processing of backslash escape characters; `%b` is used to force interpretation of the backslash escape characters in the string argument.

Here are a few `printf` examples:

```
$ printf "The octal value for %d is %o\n" 20 20
```

```
The octal value for 20 is 24
```

```
$ printf "The hexadecimal value for %d is %x\n" 30 30
```

```
The hexadecimal value for 30 is 1e
```

```
$ printf "The unsigned value for %d is %u\n" -1000 -1000
```

```
The unsigned value for -1000 is 4294966296
```

```
$ printf "This string contains a backslash escape: %s\n" "test\nstring"
```

```
This string contains a backslash escape: test\nstring
```

```
$ printf "This string contains an interpreted escape: %b\n" "test\nstring"
```

```
This string contains an interpreted escape: test string
```

```
$ printf "A string: %s and a character: %c\n" hello A
```

```
A string: hello and a character: A
```

```
$
```

In the last `printf`, `%c` is used to display a single character. If the corresponding argument is longer than one character, only the first is displayed:

```
$ printf "Just the first character: %c\n" abc
```

```
a
```

```
$
```

The general format of a conversion specification is

```
%[flags][width][.precision]type
```

The *type* is the conversion specification character from [Table 10.2](#). As you can see, only the percent sign and *type* are required; the other parameters are called *modifiers* and are optional. Valid *flags* are `-`, `+`, `#`, and the space character. `-` left justifies the value being printed; this will make more sense when we discuss the *width* modifier. `+` causes `printf` to precede integers with a `+` or `-` sign (by default, only negative integers are printed with a sign). `#` causes `printf` to precede octal integers with `0` and hexadecimal integers with `0x` or `0X` for `%#x` or `%#X`, respectively. The space character causes `printf` to precede positive integers with a space and negative integers with a `-`.

```
$ printf "%+d\n%+d\n%+d\n" 10 -10 20
```

```
+10
```

```
-10
```

```
+20
```

```
$ printf "% d\n% d\n% d\n" 10 -10 20
```

```
 10
```

```
-10
```

20

```
$ printf "%#o %#x\n" 100 200
```

```
0144 0xc8
```

```
$
```

As you can see, using `+` or space as the *flag* lines up columns of positive and negative numbers nicely.

The *width* modifier is a positive number that specifies the minimum *field width* for printing an argument. The argument is right justified within this field unless the `-` flag is used:

```
$ printf "%20s%20s\n" string1 string2
```

```
                string1                string2
```

```
$ printf "%-20s%-20s\n" string1 string2
```

```
string1                string2
```

```
$ printf "%5d%5d%5d\n" 1 10 100
```

```
    1    10   100
```

```
$ printf "%5d%5d%5d\n" -1 -10 -100
```

```
   -1   -10  -100
```

```
$ printf "%-5d%-5d%-5d\n" 1 10 100
```

```
1     10    100
```

```
$
```

The *width* modifier can be useful for lining up columns of text or numbers (note that signs for numbers and leading `0`, `0x`, and `0X` characters are counted as part of the argument's width). The *width* specifies a *minimum* size for the field; if the width of an argument exceeds *width*, it is not truncated.

The *.precision* modifier is a positive number that specifies a minimum number of digits to be displayed for `%d`, `%u`, `%o`, `%x`, and `%X`. This results in *zero padding* on the left of the value:

```
$ printf "%.5d %.4X\n" 10 27
```

```
00010 001B
```

```
$
```

For strings, the *.precision* modifier specifies the maximum number of characters to be printed from the string; if the string is longer than *precision* characters, it is truncated on the right:

```
$ printf "%.5s\n" abcdefg
```

```
abcde
```

```
$
```

A *width* can be combined with *.precision* to specify both a field width and zero padding (for numbers) or truncation (for strings):

```
$ printf ":%#10.5x:%5.4x:%5.4d\n" 1 10 100
```

```
: 0x00001: 000a: 0100
```

```
$ printf ":%9.5s:\n" abcdefg
```

```
: abcde:
```

```
$ printf ":%-9.5s:\n" abcdefg
```

```
:abcde :
```

```
$
```

Finally, if a *\** is used in place of a number for *width* or *precision*, the argument *preceding* the value to be printed must be a number and will be used as the width or precision, respectively. If a *\** is used in place of both, two integer arguments must precede the value being printed and are used for the width and precision:

```
$ printf "%*s%*.s\n" 12 "test one" 10 2 "test two"
```

```
test one te
```



```
$ printf "%12s%10.2s\n" "test one" "test two"
```

```
test one      te
```

```
$
```

As you can see, the two `printf`s in this example produce the same results. In the first `printf`, 12 is used as the width for the first string, 10 as the width for the second string, and 2 as the precision for the second string. In the second `printf`, these numbers are specified as part of the conversion specification.

[Table 10.3](#) summarizes the various conversion specification modifiers.

### Table 10.3. `printf` Conversion Specification Modifiers

Modifier	Meaning
----------	---------

*flags*

- Left justify value.

+ Precede integer with + or -.

*(space)* Precede positive integer with space character.

# Precede octal integer with 0, hexadecimal integer with 0x or 0X.

*width* Minimum width of field; \* means use next argument as width.

*precision* Minimum number of digits to display for integers; maximum number of characters to display for strings; \* means use next argument as precision.

Here's a simple example that uses `printf` to align two columns of numbers from a file:

```
$ cat align
```

```
#
```

```
# Align two columns of numbers
```

```
# (works for numbers up to 12 digits long, including sign)
```

```
cat $* |
```

```
while read number1 number2
```

```
do
    printf "%12d %12d\n" $number1 $number2
done

$ cat data
1234 7960
593 -595
395 304
3234 999
-394 -493

$ align data
    1234      7960
      593     -595
      395      304
     3234     999
    -394     -493

$
```

In [Chapters 12](#), [14](#), and [15](#) you'll see more uses for `printf`. But first try your hand at the following exercises.

## Exercises

- 1: What happens to `mycp` if one or more of the files to be copied doesn't exist? Can you make any suggestions to better handle the situation?
- 2: What happens to `mycp` if one of the filenames contains a character that has a special meaning to the shell such as `;` or `|`?
- 3: Write a program called `mymv` that does with the `mv` command what `mycp` does with the `cp` command. How many changes did you have to make to `mycp` to produce this new program?
- 4: Modify `mycp` to prompt for arguments if none are supplied. A typical execution of the modified version should look like this:

```
$ mycp
Source file name? voucher
Destination file name? voucher.sv
$
```

Make sure that the program allows one or both of the files to be specified with filename substitution characters.

- 5: Add a `-n` option to `mycp` that suppresses the normal check for the existence of the destination files.
- 6: Modify `mycp` to use `sed` instead of the `while` loop to process the arguments typed on the command line.
- 7: Modify the `rem` program used by `rolo` so that if multiple entries are found, the program will prompt the user for the entry to be removed.

Here's a sample session:

```
$ rolo
...
```

Please select one of the above (1-3): 3

Enter name to be removed: **Susan**

More than one match; please select the one to remove:

Susan Goldberg      Remove (y/n)? **n**

Susan Topple        Remove (y/n)? **y**

\$

- 8: Modify `rolo` so that the menu is redisplayed after each selection is made and processed. To allow the user to get out of this, add another selection to the menu to exit from the program.
- 9: What happens to the `rolo` program if just an Enter is given as the name for the add, look up, or remove options?
- 10: Modify `lu` to use `printf` to print the name and phone number so that they line up in columns for names up to 40 characters in length (Hint: use `cut -f` and the fact that the fields in the `phonebook` are separated by tabs).

# Chapter 11. Your Environment

## IN THIS CHAPTER

- [Local Variables](#)
- [Exported Variables](#)
- [PS1 and PS2](#)
- [HOME, James](#)
- [Your PATH](#)
- [Your Current Directory](#)
- [More on Subshells](#)
- [Your .profile File](#)
- [The TERM Variable](#)
- [The TZ Variable](#)
- [Exercises](#)

When you log on to the system, you're effectively given your own copy of the shell program. This shell maintains what's known as your *environment*—an environment that is distinct from other users on the system. This environment is maintained from the moment you log on until the moment you log off. In this chapter you'll learn about this environment in detail, and you'll see how it relates to writing and running programs.

## Local Variables

Type the following program called `vartest` into your computer:

```
$ cat vartest
```

```
echo :$x:
```

```
$
```

`vartest` consists of a solitary `echo` command that displays the value of the variable `x`, surrounded by colons. Now assign any value you want to the variable `x` from your terminal:

```
$ x=100
```

Here we chose 100. Question: What do you think will be displayed when `vartest` is now executed?  
Answer:

```
$ vartest
```

```
::
```

```
$
```

`vartest` doesn't know about the value of `x`. Therefore, its value is null. The variable `x` that was assigned the value `100` in the login shell is known as a *local* variable. The reason why it has this name will become clear shortly.

Here's another example. This program is called `vartest2`:

```
$ cat vartest2
```

```
x=50
```

```
echo :$x:
```

```
$ x=100

$ vartest2           Execute it

:50:

$
```

Now the question is: What's the value of `x`?

```
$ echo $x

100

$
```

So you see that `vartest2` didn't change the value of `x` that you set equal to `100` in your login shell.

## Subshells

The behavior exhibited by `vartest` and `vartest2` is due to the fact that these two programs are run as *subshells* by your login shell. A subshell is, for all intents and purposes, an entirely new shell executed by your login shell to run the desired program. So when you ask your login shell to execute `vartest`, it starts up a new shell to execute the program. Whenever a new shell runs, it runs in its own environment, with its own set of local variables. *A subshell has no knowledge of local variables that were assigned values by the login shell (the "parent" shell).* Furthermore, a subshell cannot change the value of a variable in the parent shell, as evidenced by `vartest2`.

Let's review the process that goes on here. Before executing `vartest2`, your login shell has a variable called `x` that has been assigned the value `100` (assume for now that this is the only variable defined in the shell). This is depicted in [Figure 11.1](#).

Figure 11.1. Login shell with `x=100`.

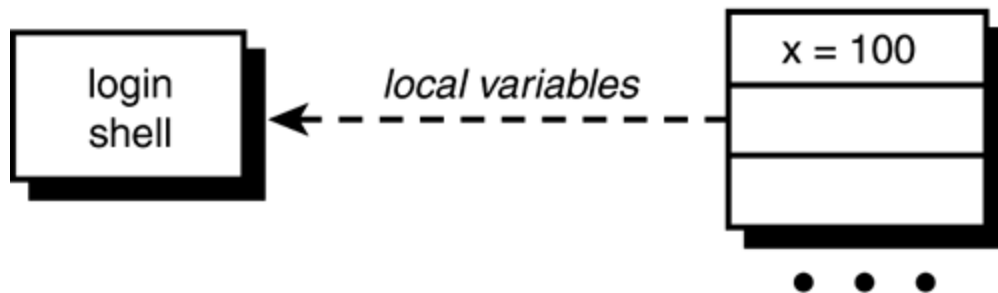

When you ask to have `vartest2` executed, your login shell starts up a subshell to run it, giving it an empty list of local variables to start with (see [Figure 11.2](#)).

Figure 11.2. Login shell executes `vartest2`.

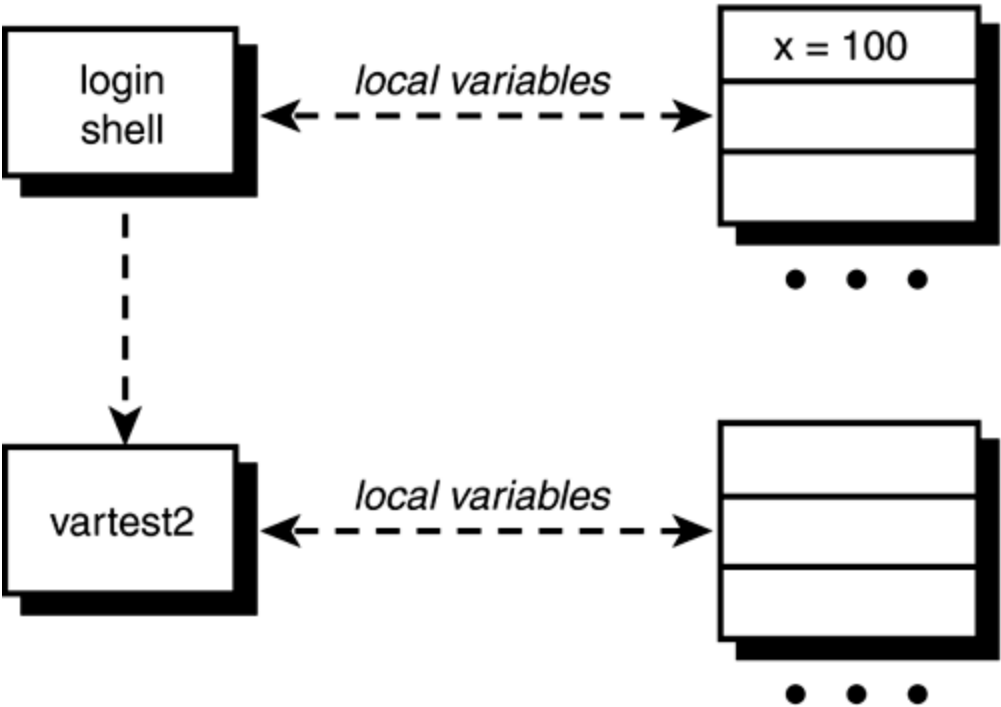

After the first command in `vartest2` is executed (that assigns `50` to `x`), the local variable `x` that exists in the subshell's environment will have the value `50` (see [Figure 11.3](#)). Note that this has no relation whatsoever to the variable `x` that still maintains its value of `100` in the login shell.

Figure 11.3. `vartest2` executes `x=50`.



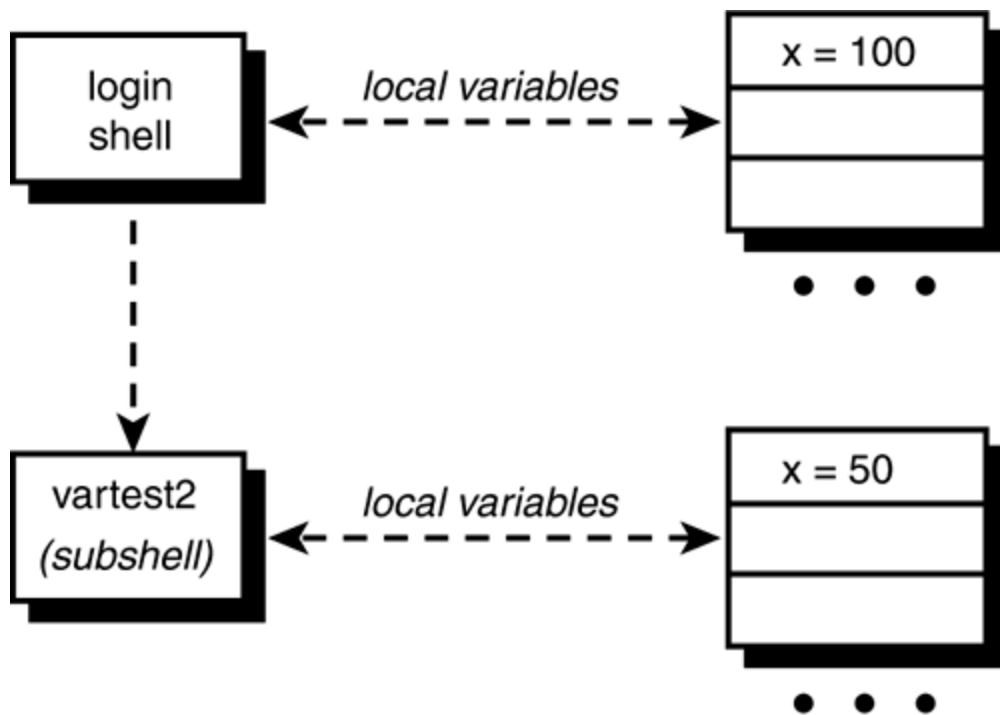

When `vartest2` finishes execution, the subshell goes away, *together with any variables assigned values.*

## Exported Variables

There *is* a way to make the value of a variable known to a subshell, and that's by *exporting* it with the `export` command. The format of this command is simply

```
export variables
```

where *variables* is the list of variable names that you want exported. For any subshells that get executed from that point on, the value of the exported variables will be passed down to the subshell.

Here's a program called `vartest3` to help illustrate the difference between local and exported variables:

```
$ cat vartest3
echo x = $x
echo y = $y
$
```

Assign values to the variables `x` and `y` in the login shell, and then run `vartest3`:

```
$ x=100
$ y=10
$ vartest3
x =
y =
$
```

`x` and `y` are both local variables, so their values aren't passed down to the subshell that runs `vartest3`. Now let's export the variable `y` and try it again:

```

$ export y                Make y known to subshells

$ vartest3

x =

y = 10

$

```

This time, `vartest3` knew about `y` because it is an exported variable. Conceptually, whenever a subshell is executed, the list of exported variables gets "copied down" to the subshell, whereas the list of local variables does not (see [Figure 11.4](#)).

Figure 11.4. Execution of `vartest3`.

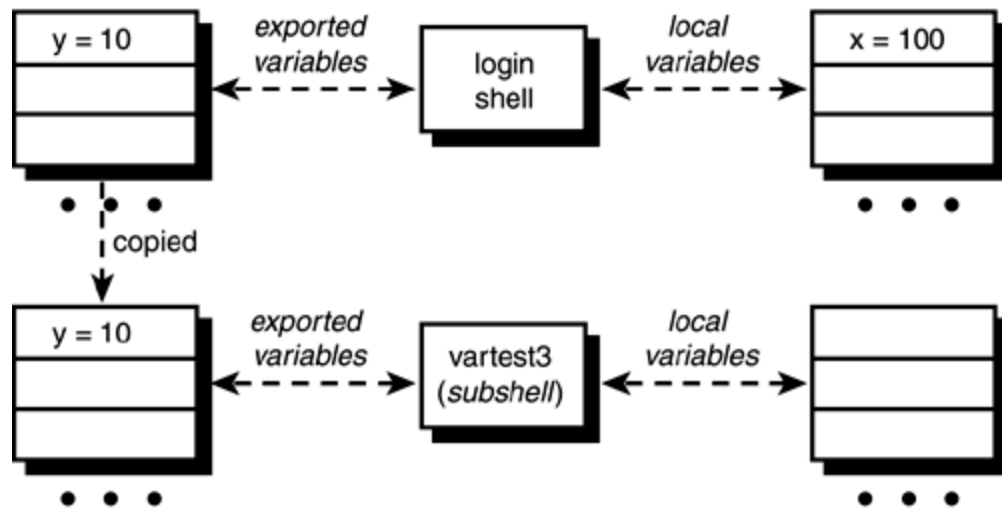

Now it's time for another question: What do you think happens if a subshell changes the value of an exported variable? Will the parent shell know about it after the subshell has finished? To answer this question, here's a program called `vartest4`:

```

$ cat vartest4

x=50

y=5

$

```

We'll assume that you haven't changed the values of `x` and `y`, and that `y` is still exported.

```
$ vartest4  
  
$ echo $x $y  
  
100 10  
  
$
```

So the subshell couldn't even change the value of the exported variable `y`; it merely changed the copy of `y` that was passed to its environment when it was executed (see [Figure 11.5](#)). Just as with local variables, when a subshell goes away, so do the values of the exported variables. *There is no way to change the value of a variable in a parent shell from within a subshell.*

Figure 11.5. Execution of `vartest4`.

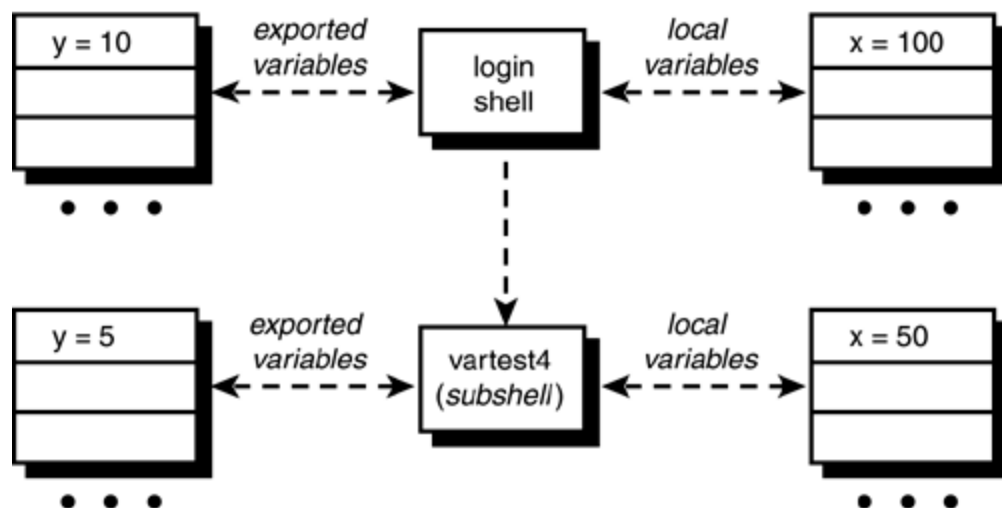

In the case of a subshell executing another subshell (for example, the `rolo` program executing the `lu` program), the process is repeated: The exported variables from the subshell are copied to the new subshell. These exported variables may have been exported from above, or newly exported from within the subshell.

*After a variable is exported, it remains exported to all subshells subsequently executed.*

Consider a modified version of `vartest4`:

```
$ cat vartest4
```

```
x=50
y=5
z=1
export z
vartest5
$
```

and also consider `vartest5`:

```
$ cat vartest5
echo x = $x
echo y = $y
echo z = $z
$
```

When `vartest4` gets executed, the exported variable `y` will be copied into the subshell's environment. `vartest4` sets the value of `x` to 50, changes the value of `y` to 5, and sets the value of `z` to 1. Then it exports `z`. This makes the value of `z` accessible to any subshell subsequently run by `vartest4`. `vartest5` is such a subshell, and when it is executed, the shell copies into its environment the exported variables from `vartest4`: `y` and `z`. This should explain the following output:

```
$ vartest4
x =
y = 5
z = 1
$
```

This entire operation is depicted in [Figure 11.6](#).

Figure 11.6. Subshell execution.

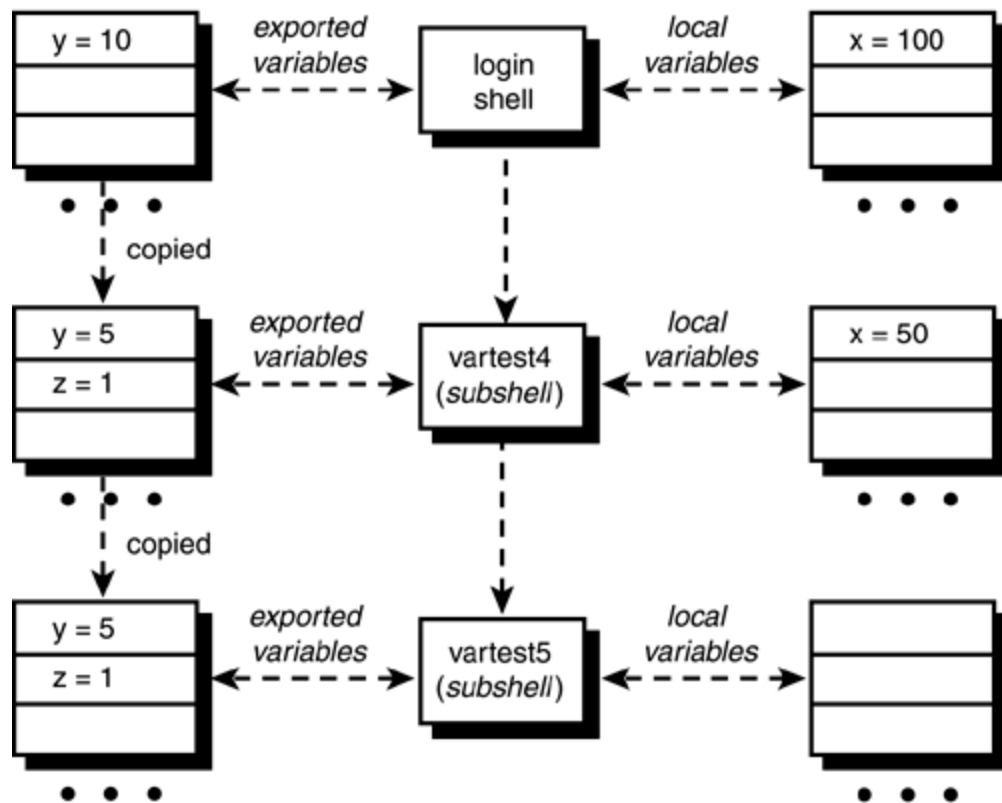

To summarize the way local and exported variables work:

1. Any variable that is not exported is a local variable whose existence will not be known to subshells.
2. Exported variables and their values are copied into a subshell's environment, where they may be accessed and changed. However, such changes have no effect on the variables in the parent shell.
3. Exported variables retain this characteristic not only for directly spawned subshells, but also for subshells spawned by those subshells (and so on down the line).
4. A variable can be exported any time before or after it is assigned a value.

`export -p`

If you simply type `export -p`, you'll get a list of the variables and their values exported by your shell:

```
$ export -p  
  
export LOGNAME=steve  
  
export PATH=/bin:/usr/bin:.  
  
export TIMEOUT=600  
  
export TZ=EST5EDT  
  
export y=10  
  
$
```

As you can see, there are actually more exported variables here than you were initially led to believe. Note that `y` shows up on the list, together with other variables that were exported when you logged on.

Note that the variables listed include those that have been inherited from a parent shell.

**Team LiB**

[◀ PREVIOUS](#)

[NEXT ▶](#)

## PS1 and PS2

The characters that the shell displays as your command prompt are stored in the variable `PS1`. You can change this variable to be anything you want. As soon as you change it, it'll be used by the shell from that point on.

```
$ echo :$PS1:
:$ :
$ PS1=="==> "
==> pwd
/users/steve
==> PS1="I await your next command, master: "
I await your next command, master: date
Wed Sep 18 14:46:28 EDT 2002
I await your next command, master: PS1="$ "
$                               Back to normal
```

Your secondary command prompt, normally `>`, is kept in the variable `PS2`, where you can change it to your heart's content:

```
$ echo :$PS2:
:> :
$ PS2="=====> "
$ for x in 1 2 3
=====> do
=====> echo $x
=====> done
```



1  
2  
3  
\$

Like any other shell variables, after you log off the system, the values of those variables go with it. So if you change `PS1`, the shell will use the new value for the remainder of your login session. Next time you log in, however, you'll get the old value again. You can make the change yourself every time you log in, or you can have the change made automatically by adding it to your `.profile` file (discussed later in this chapter).

## HOME, James

Your home directory is where you're placed whenever you log on to the system. A special shell variable called `HOME` is also automatically set to this directory when you log on:

```
$ echo $HOME
```

```
/users/steve
```

```
$
```

This variable can be used by your programs to identify your home directory. It's also used by the `cd` command whenever you type just `cd` with no arguments:

```
$ pwd Where am I?
```

```
/usr/src/lib/libc/port/stdio
```

```
$ cd
```

```
$ pwd
```

```
/users/steve There's no place like home
```

```
$
```

You can change your `HOME` variable to anything you want, but be warned that doing so may affect the operation of any programs that rely on it:

```
$ HOME=/users/steve/book Change it
```

```
$ pwd
```

```
/users/steve
```

```
$ cd
```

```
$ pwd See what happened
```

/users/steve/book

\$

**Team LiB**

**◀ PREVIOUS**

**NEXT ▶**

## Your PATH

Return for a moment to the `rolo` program from [Chapter 10](#), "Reading and Printing Data":

```
$ rolo Liz
Liz Stachiw      212-555-2298
$
```

Let's see what directory this program was created in:

```
$ pwd
/users/steve/bin
$
```

Okay, now change directory to anywhere you want:

```
$ cd /usr/bin
$
```

And now try to look up Liz in the phone book:

```
$ rolo Liz
sh: rolo: not found
$
```

Unless you already know where this discussion is leading, you are likely to get the preceding results.

Whenever you type in the name of a program to be executed, the shell searches a list of directories until it finds the requested program.<sup>[1]</sup> When found, it initiates its execution. This list of directories is contained in a special shell variable called `PATH`. This variable is automatically set for you when you log on to the system. See what it's set to now:

<sup>[1]</sup> *Actually, the shell is a bit more intelligent, because it keeps track of where it finds each command you execute. When you re-execute one of these commands, the shell remembers where it was found and doesn't go searching for it again. This feature is known as hashing.*

```
$ echo $PATH
```

```
/bin:/usr/bin:.
```

```
$
```

Chances are that your `PATH` has a slightly different value. As noted, the `PATH` specifies the directories that the shell searches to execute a command. These directories are separated from one another by colons (:). In the preceding example, three directories are listed: `/bin`, `/usr/bin`, and `.` (which, you'll recall, stands for the current directory). So whenever you type in the name of a program, say for example `rolo`, the shell searches the directories listed in `PATH` from left to right until it finds an executable file called `rolo`. First it looks in `/bin`, then in `/usr/bin`, and finally in the current directory for an executable file called `rolo`. As soon as it finds `rolo`, the shell executes it; if the shell doesn't find `rolo`, the shell issues a "not found" message.

The path

```
/bin:./usr/bin
```

specifies to search `/bin`, followed by the current directory, followed by `/usr/bin`. To have the current directory searched first, you put the period at the start of the path:

```
./bin:/usr/bin
```

For security reasons, it's generally not a good idea to have your current directory searched before the system ones.<sup>[2]</sup>

*This is to avoid the so-called Trojan horse problem: Someone stores her own version of a command such as `su` (the command that changes you to another user) in a directory she can write into and waits for another user to change to that directory and run `su`. If the `PATH` specifies that the current directory be searched first, then the horsed version of `su` will be executed. This version will get the password that is typed and then print out `Sorry`. The user will think he just typed the wrong*

*password.*

The period for specifying the current directory is optional; for example, the path

```
:/bin:/usr/bin
```

is equivalent to the previous one; however, throughout this text we'll specify the current directory with a period for clarity.

You can always override the `PATH` variable by specifying a path to the file to be executed. For example, if you type

```
/bin/date
```

the shell goes directly to `/bin` to execute `date`. The `PATH` in this case is ignored, as it is if you type in

```
../bin/lu
```

or

```
./rolo
```

This last case says to execute the program `rolo` in the current directory.

So now you understand why you couldn't execute `rolo` from your `HOME` directory: `/users/steve/bin` wasn't included in your `PATH`, and so the shell couldn't find `rolo`. This is a simple matter to rectify. You can simply add this directory to your `PATH`:

```
$ PATH=/bin:/usr/bin:./users/steve/bin
```

```
$
```

Now *any* program in `/users/steve/bin` can be executed by you from *anywhere*.

```
$ pwd Where am I?
```

```
/users/steve
```

```
$ rolo Liz
```

```
grep: can't open phonebook
```

```
$
```

This time the shell finds `rolo` and executes it, but `grep` can't find the `phonebook` file. Look back at the `rolo` program, and you'll see that the `grep` error message must be coming from `lu`. Take another look at `lu`:

```
$ cat /users/steve/bin/lu
```

```
#
```

```
# Look someone up in the phone book -- version 3
```

```
#
```

```
if [ "$#" -ne 1 ]
```

```
then
```

```
    echo "Incorrect number of arguments"
```

```
    echo "Usage: lu name"
```

```
    exit 1
```

```
fi
```

```
grep "$name" phonebook
```

```
$
```

`grep` is trying to open the `phonebook` file in the current directory, which is `/users/steve` (that's where the program is being executed from—the current directory has no relation to the directory in

which the program itself resides).

The `PATH` only specifies the directories to be searched for programs to be executed, and not for any other types of files. So `phonebook` must be precisely located for `lu`. There are several ways to fix this problem—a problem which, by the way, exists with the `rem` and `add` programs as well. One approach is to have the `lu` program change directory to `/users/steve/bin` before it does the `grep`. That way, `grep` finds `phonebook` because it exists in the current directory:

...

```
cd /users/steve/bin
```

```
grep "$1" phonebook
```

This approach is a good one to take when you're doing a lot of work with different files in a particular directory: simply `cd` to the directory first and then you can directly reference all the files you need.

A second approach is to simply list a full path to `phonebook` in the `grep` command:

...

```
grep "$1" /users/steve/bin/phonebook
```

But suppose that you want to let others use your `rolo` program (and associated `lu`, `add`, and `rem` programs). You can give them each their own copy, and then you'll have several copies of the identical program on the system—programs that you'll probably have to maintain. And what happens if you make a small change to `rolo`? Are you going to update all their copies as well? A better solution might be to keep just one copy of `rolo` but to give other users access to it.<sup>[3]</sup>

<sup>[3]</sup> This can be done by giving them execute permission on all the directories leading to `rolo`, as well as read and execute permissions on the programs themselves. They can always copy your programs at that point, but you won't have to maintain them.

If you change all the references of `phonebook` to explicitly reference *your* phone book, everyone else who uses your `rolo` program will be using *your* phone book, and not his own. One way to solve the problem is to require that everyone have a `phonebook` file in his home directory; this way, if the program references the file as `$HOME/phonebookw`, it will be relative to the home directory of the person running the program.

Let's try this approach: Define a variable inside `rolo` called `PHONEBOOK` and set it to `$HOME/phonebook`. If you then export this variable, `lu`, `rem`, and `add` (which are executed as subshells by `rolo`) can use the value of `PHONEBOOK` to reference the file. One advantage of this is if in the future you change the location of the `phonebook` file, all you'll have to do is change this one variable in `rolo`; the other three programs can remain untouched.



Here is the new `rolo` program, followed by modified `lu`, `add`, and `rem` programs.

```
$ cd /users/steve/bin

$ cat rolo

#

# rolo - rolodex program to look up, add, and
#       remove people from the phone book
#

#

# Set PHONEBOOK to point to the phone book file
# and export it so other progs know about it
#

PHONEBOOK=$HOME/phonebook

export PHONEBOOK

if [ ! -f "$PHONEBOOK" ]

then

    echo "No phone book file in $HOME!"

    exit 1

fi

#

# If arguments are supplied, then do a lookup
#
```

```
if [ "$#" -ne 0 ]
then
    lu "$@"
    exit
fi
validchoice=""          # set it null

#
# Loop until a valid selection is made
#

until [ -n "$validchoice" ]
do
    #
    # Display menu
    #

    echo '
Would you like to:

1. Look someone up
2. Add someone to the phone book
3. Remove someone from the phone book

Please select one of the above (1-3): \c'
```

```
#
# Read and process selection
#

read choice

echo

case "$choice"

in

    1) echo "Enter name to look up: \c"

        read name

        lu "$name"

        validchoice=TRUE;;

    2) echo "Enter name to be added: \c"

        read name

        echo "Enter number: \c"

        read number

        add "$name" "$number"

        validchoice=TRUE;;

    3) echo "Enter name to be removed: \c"

        read name

        rem "$name"

        validchoice=TRUE;;

    *) echo "Bad choice";;

esac

done
```

```
$ cat add

#

# Program to add someone to the phone book file

#

if [ "$#" -ne 2 ]

then

    echo "Incorrect number of arguments"

    echo "Usage: add name number"

    exit 1

fi

echo "$1      $2" >> $PHONEBOOK

sort -o $PHONEBOOK $PHONEBOOK

$ cat lu

#

# Look someone up in the phone book

#

if [ "$#" -ne 1 ]

then

    echo "Incorrect number of arguments"

    echo "Usage: lu name"

    exit 1

fi
```

```
name=$1

grep "$name" $PHONEBOOK

if [ $? -ne 0 ]

then

    echo "I couldn't find $name in the phone book"

fi

$ cat rem

#

# Remove someone from the phone book

#

if [ $# -ne 1 ]

then

    echo "Incorrect number of arguments"

    echo "Usage: rem name"

    exit 1

fi

name=$1

#

# Find number of matching entries

#

matches=$(grep "$name" $PHONEBOOK | wc -l)
```

```

#
# If more than one match, issue message, else remove it
#

if [ "$matches" -gt 1 ]
then
    echo "More than one match; please qualify further"
elif [ "$matches" -eq 1 ]
then
    grep -v "$name" $PHONEBOOK > /tmp/phonebook$$
    mv /tmp/phonebook$$ $PHONEBOOK
else
    echo "I couldn't find $name in the phone book"
fi
$

```

(In an effort to be more user-friendly, a test was added to the end of `lu` to see whether the `grep` succeeds; if it doesn't, a message is displayed to the user.)

Now to test it:

```

$ cd Return home

$ rolo Liz Quick lookup

No phonebook file in /users/steve! Forgot to move it

$ mv /users/steve/bin/phonebook .

$ rolo Liz Try again

Liz Stachiw 212-555-2298

```

\$ rolo

*Try menu selection*

Would you like to:

1. Look someone up
2. Add someone to the phone book
3. Remove someone from the phone book

Please select one of the above (1-3): **2**

Enter name to be added: **Teri Zak**

Enter number: **201-555-6000**

\$ rolo Teri

Teri Zak            201-555-6000

\$

rolo, lu, and add seem to be working fine. rem should also be tested to make sure that it's okay as well.

If you still want to run lu, rem, or add standalone, you can do it provided that you first define PHONEBOOK and export it:

```
$ PHONEBOOK=$HOME/phonebook
```

```
$ export PHONEBOOK
```

```
$ lu Harmon
```

I couldn't find Harmon in the phone book

\$

If you do intend to run these programs standalone, you'd better put checks in the individual

programs to ensure that **PHONEBOOK** is set to some value.

**Team LiB**

[◀ PREVIOUS](#)

[NEXT ▶](#)



## Your Current Directory

Your current directory is also part of your environment. Take a look at this small shell program called `cdtest`:

```
$ cat cdtest
cd /users/steve/bin
pwd
$
```

The program does a `cd` to `/users/steve/bin` and then executes a `pwd` to verify that the change was made. Let's run it:

```
$ pwd                               Get my bearings
/users/steve
$ cdtest
/users/steve/bin
$
```

Now for the \$64,000 question: If you execute a `pwd` command now, will you be in `/users/steve` or `/users/steve/bin`?

```
$ pwd
/users/steve
$
```

The `cd` executed in `cdtest` had no effect on your current directory. Because the current directory is part of the environment, when a `cd` is executed from a subshell, the current directory of that subshell

is altered. *There is no way to change the current directory of a parent shell from a subshell.*

When `cd` is invoked, it sets the `PWD` shell variable to the full pathname of the new current directory, so the command

```
echo $PWD
```

produces the same output as the `pwd` command:

```
$ pwd
/users/steve
$ echo $PWD
/users/steve
$ cd bin
$ echo $PWD
/users/steve/bin
$
```

`cd` also sets `OLDPWD` to the full pathname of the previous current directory.

Incidentally, `cd` is a shell built-in command.

### **CDPATH**

The `CDPATH` variable works like the `PATH` variable: It specifies a list of directories to be searched by the shell whenever you execute a `cd` command. This search is done only if the specified directory is not given by a full pathname and if `CDPATH` is not null (obviously). So if you type in

```
cd /users/steve
```

the shell changes your directory directly to `/users/steve`; but if you type

```
cd memos
```

the shell looks at your `CDPATH` variable to find the `memos` directory. And if your `CDPATH` looks like this:

```
$ echo $CDPATH
```

```
.: /users/steve: /users/steve/docs
```

```
$
```

the shell first looks in your current directory for a `memos` directory, and if not found then looks in `/users/steve` for a `memos` directory, and if not found there tries `/users/steve/docs` in a last ditch effort to find the directory. If the directory that it finds is not relative to your current one, the `cd` command prints the full path to the directory to let you know where it's taking you:

```
$ cd /users/steve
```

```
$ cd memos
```

```
/users/steve/docs/memos
```

```
$ cd bin
```

```
/users/steve/bin
```

```
$
```

Like the `PATH` variable, use of the period for specifying the current directory is optional, so

```
:/users/steve:/users/steve/docs
```

is equivalent to

```
.: /users/steve: /users/steve/docs
```

Judicious use of the `CDPATH` variable can save you a lot of typing, especially if your directory hierarchy is fairly deep and you find yourself frequently moving around in it (or if you're frequently moving around into other directory hierarchies as well).

Unlike the `PATH`, you'll probably want to put your current directory first in the `CDPATH` list. This gives you the most natural use of `CDPATH` (because you're used to doing a `cd x` to switch to the subdirectory `x`). If the current directory isn't listed first, you may end up in an unexpected directory.

Team LiB

◀ PREVIOUS

NEXT ▶

## More on Subshells

It's important for you to understand the way subshells work and how they interact with your environment. You know now that a subshell can't change the value of a variable in a parent shell, nor can it change its current directory. Suppose that you want to write a program to set values for some variables that you like to use whenever you log on. For example, assume that you have the following file called `vars`:

```
$ cat vars
BOOK=/users/steve/book
UUPUB=/usr/spool/uucppublic
DOCS=/users/steve/docs/memos
DB=/usr2/data
$
```

You know that if you execute `vars`, the values assigned to these variables will not be accessible by you after this program has finished executing because `vars` will be run in a subshell:

```
$ vars
$ echo $BOOK
$
```

## The `.` Command

Luckily, there is a shell built-in command called `.` (pronounced "dot") whose general format is

```
. file
```

and whose purpose is to execute the contents of *file* in the *current* shell. That is, commands from *file* are executed by the current shell just as if they were typed at that point. A subshell is not spawned to execute the program. The shell uses your **PATH** variable to find *file*, just like it does when executing other programs.

```
$ . vars                               Execute vars in the current shell
$ echo $BOOK
/users/steve/book                      Hoorah!
$
```

Because a subshell isn't spawned to execute the program, any variable that gets assigned a value stays even after execution of the program is completed. It follows then that if you have a program called **db** that has the following commands in it:

```
$ cat db
DATA=/usr2/data
RPTS=$DATA/rpts
BIN=$DATA/bin

cd $DATA
$
```

executing **db** with the "dot" command

```
$ . db
$
```

defines the three variables **DATA**, **RPTS**, and **BIN** in the current shell and then changes you to the **\$DATA** directory.

```
$ pwd
```

```
/usr2/data
```

```
$
```

This last example brings up an interesting point of discussion. If you're one of those Unix users who have to support a few different directory hierarchies, you can create programs like `db` to execute whenever you have to work on one of your directories. In that program, you can also include definitions for other variables; for example, you might want to change your prompt in `PS1` to something like `DB`—to let you know that your database variables have been set up. You may also want to change your `PATH` to include a directory that has programs related to the database and your `CDPATH` variable so that directories in the database will be easily accessible with the `cd` command. You can even change `HOME` so that a `cd` without any arguments returns you directly to your database directory.

If you make these sorts of changes, you'll probably want to execute `db` in a subshell and not in the current shell because doing the latter leaves all the modified variables around after you've finished your work on the database. The trick to doing it right is to start up a *new* shell from inside the subshell, with all the modified variables exported to it. Then, when you're finished working with the database, you can "log off" the new shell by pressing *Ctrl+d*. Let's take a look at how this works. Here is a new version of `db`:

```
$ cat db
```

```
#
```

```
# Set up and export variables related to the data base
```

```
#
```

```
HOME=/usr2/data
```

```
BIN=$HOME/bin
```

```
RPTS=$HOME/rpts
```

```
DATA=$HOME/rawdata
```

```
PATH=$PATH$BIN
```

```
CDPATH=: $HOME : $RPTS
```

```
PS1="DB: "
```

```
export HOME BIN RPTS DATA PATH CDPATH PS1
```

```
#
```

```
# Start up a new shell
```

```
#
```

```
/usr/bin/sh
```

```
$
```

The **HOME** directory is set to `/usr2/data`, and then the variables **BIN**, **RPTS**, and **DATA** are defined relative to this **HOME** (a good idea in case you ever have to move the directory structure somewhere else: all you'd have to change in the program is the variable **HOME**).

Next, the **PATH** is modified to include the database **bin** directory, and the **CDPATH** variable is set to search the current directory, the **HOME** directory, and the **RPTS** directory (which presumably contains subdirectories).

After exporting these variables (which as you recall must be done to put the values of these variables into the environment of subsequently spawned subshells), the standard shell, `/usr/bin/sh`, is started. From that point on, this new shell processes commands typed in from the terminal. When `Ctrl+d` is typed to this shell, control returns to **db**, which in turn returns control to your login shell.

```
$ db
```

*Run it*

```
DB: echo $HOME
```

```
/usr2/data
```

```
DB: cd rpts
```

*Try out CDPATH*

```
/usr2/data/rpts
```

*It works*

```
DB: ps
```

*See what processes are running*

```
PID TTY TIME COMMAND
```



```
123 13 0:40 sh Your login shell
761 13 0:01 sh Subshell running db
765 13 0:01 sh New shell run from db
769 13 0:03 ps
DB: Ctrl+d Done for now
$ echo $HOME
/users/steve Back to normal
$
```

The execution of `db` is depicted in [Figure 11.7](#) (where we've shown only the exported variables of interest, not necessarily all that exist in the environment).

Figure 11.7. Executing `db`.

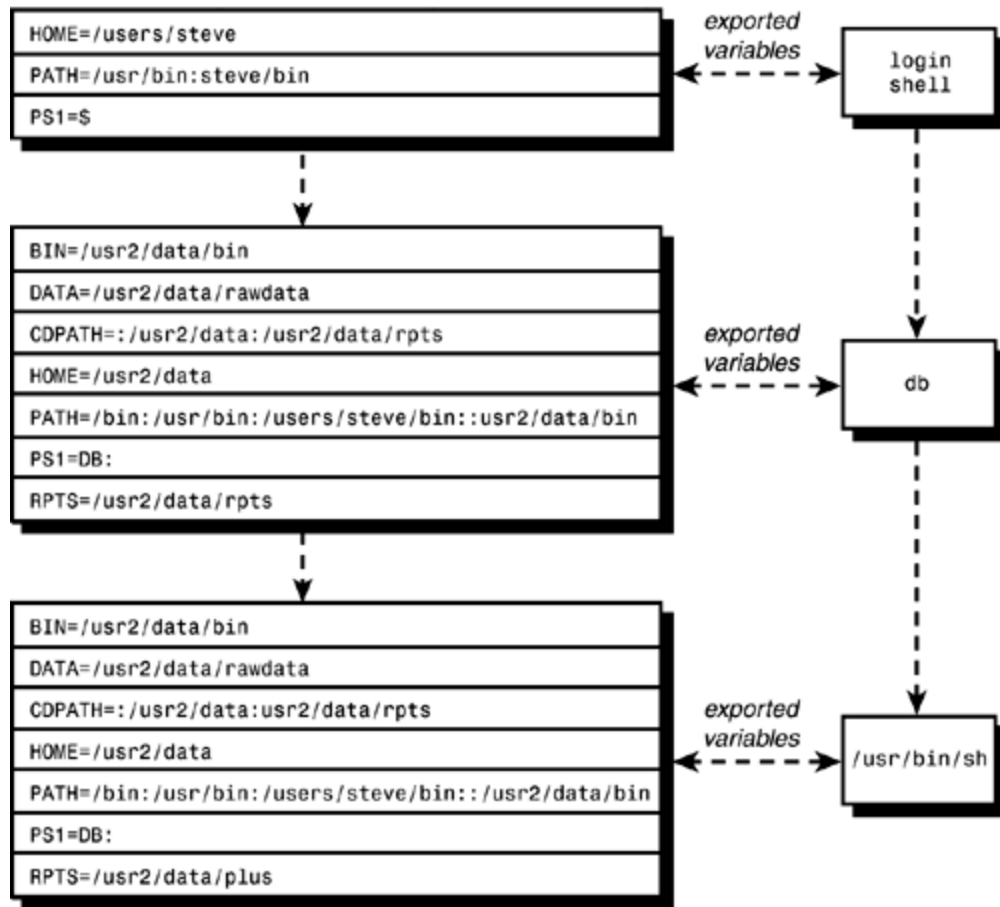

## The `exec` Command

After you started up the new shell from `db`, you weren't interested in doing anything further after the shell finished, as evidenced by the fact that no commands followed `/usr/bin/sh` in the program. Instead of having `db` wait around for the new shell to finish, you can use the `exec` command to *replace the current program (`db`) with the new one (`/usr/bin/sh`)*. The general format of `exec` is

```
exec program
```

where *program* is the name of the program to be executed. Because the `exec`'ed program replaces the current one, there's one less process hanging around; also, startup time of an `exec`'ed program is quicker, due to the way the Unix system executes processes.

To use `exec` in the `db` program, you simply replace the last line with

```
exec /usr/bin/sh
```

As noted, after this gets executed, `db` will be replaced by `/usr/bin/sh`. This means that it's pointless to have any commands follow the `exec` because they'll never be executed.

`exec` can be used to close standard input and reopen it with any file that you want to read. To change standard input to *file*, you use the `exec` command in the form

```
exec < file
```

Any commands that subsequently read data from standard input will read from *file*.

Redirection of standard output is done similarly. The command

```
exec > report
```

redirects all subsequent output written to standard output to the file `report`. Note here that `exec` is not used to start up execution of a new program as previously described; here it is used to reassign standard input or standard output.

If you use `exec` to reassign standard input and later want to reassign it someplace else, you can simply execute another `exec`. To reassign standard input back to the terminal, you would write

```
exec < /dev/tty
```

The same discussion applies to reassignment of standard output.

## The `(...)` and `{ ...; }` Constructs

Sometimes you may want to group a set of commands together for some reason. For example, you may want to send a `sort` followed by execution of your `plotdata` program into the background for execution. You can group a set of commands together by enclosing them in a set of parentheses or braces. The first form causes the commands to be executed by a subshell, the latter form by the current shell.

Here are some examples to illustrate how they work:

```
$ x=50
```

```
$ (x=100) Execute this in a subshell
```

```
$ echo $x
```

```
50 Didn't change
```

```
$ { x=100; } Execute this in the current shell
```

```
$ echo $x
```

```
100
```

```
$ pwd Where am I?
```

```
/users/steve
```

```
$ (cd bin; ls) Change to bin and do an ls
```

```
add
```

```
greetings
```

```
lu
```

```
number
```

```
phonebook
```

```
rem
```

```
rolo
```

```
$ pwd
```

```
/users/steve No change
```

```
$ { cd bin; } This should change me
```

```
$ pwd
```

```
/users/steve/bin
```

```
$
```

If the commands enclosed in the braces are all to be typed on the same line, a space must follow the left brace, and a semicolon must appear after the last command.

As the example

```
(cd bin; ls)
```

shows, the parentheses are useful for doing some commands without affecting your current environment. You can also use them for other purposes:

```
$ (sort 2002data -o 2002data; plotdata 2002data) &
```

```
[1] 3421
```

```
$
```

The parentheses group the `sort` and `plotdata` commands together so that they can both be sent to the background for execution, with their order of execution preserved.

Input and output can be piped to and from these constructs, and I/O can be redirected. In the next example, a

```
.ls 2
```

`nroff` command (for double-spaced output) is effectively tacked to the beginning of the file `memo` before being sent to `nroff`.

```
$ { echo ".ls 2"; cat memo; } | nroff -Tlp | lp
```

In the command sequence

```
$ { prog1; prog2; prog3; } 2> errors
```

all messages written to standard error by the three programs are collected into the file `errors`.

As a final example, let's return to the `mon` program from [Chapter 9](#), "'Round and 'Round She Goes."

As you'll recall, this program periodically checked for a user logging on to the system. One of the comments we made back then is that it would be nice if the program could somehow automatically "send itself" to the background for execution because that's how it's really meant to be run. Now you know how to do it: You simply enclose the `until` loop and the commands that follow inside parentheses and send it into the background:

```
$ cat mon

#

# Wait until a specified user logs on -- version 4

#

# Set up default values

mailopt=FALSE

interval=60

# process command options

while getopts mt: option
do
    case "$option"
    in
        m)    mailopt=TRUE;;
        t)    interval=$OPTARG;;
        \?)  echo "Usage: mon [-m] [-t n] user"
            echo " -m means to be informed by mail"
            echo " -t means check every n secs."
            exit 1;;
    esac
done
```

```
done

# Make sure a user name was specified

if [ "$OPTIND" -gt "$#" ]
then
    echo "Missing user name!"
    exit 2
fi

shiftcount=$(( OPTIND - 1 ))
shift $shiftcount
user=$1

#
# Send everything that follows into the background
#

(
    #
    # Check for user logging on
    #

    until who | grep "^$user " > /dev/null
    do

        sleep $interval
```

```
done

#

# When we reach this point, the user has logged on

#

if [ "$mailopt" = FALSE]

then

    echo "$user has logged on"

else

    runner=$(who am i | cut -c1-8)

    echo "$user has logged on" | mail $runner

fi

) &
```

The entire program could have been enclosed in parentheses, but we arbitrarily decided to do the argument checking and parsing first before sending the remainder to the background.

```
$ mon fred

$                                     Prompt comes back so you can continue working

...

fred has logged on
```

Note that a process id number is not printed by the shell when a command is sent to the background within a shell program.

## Another Way to Pass Variables to a Subshell



If you want to send the value of a variable to a subshell, there's another way to do it besides setting the variable and then exporting it. On the command line, you can precede the name of the command with the assignment of as many variables as you want. For example,

```
DBHOME=/uxn2/data DBID=452 dbrun
```

places the variables `DBHOME` and `DBID`, and their indicated values, into the environment of `dbrun` and then `dbrun` gets executed. These variables will not be known to the current shell; they're created only for the execution of `dbrun`. In fact, execution of the preceding command behaves identically to typing

```
(DBHOME=/uxn2/data; DBID=452; export DBHOME DBID; dbrun)
```

Here's a short example:

```
$ cat fool
echo :$x:
foo2
$ cat foo2
echo :$x:
$ fool
::
::          x not known to fool or foo2
$ x=100 fool          Try it this way
:100:              x is known to fool
:100:              and to its subshells
$ echo :$x:
::                Still not known to current shell
$
```

So variables defined this way otherwise behave as normal exported variables to the subshell.

**Team LiB**

[◀ PREVIOUS](#)

[NEXT ▶](#)

## Your `.profile` File

In [Chapter 3](#), "What Is the Shell?," you learned about the login sequence. This sequence is completed when your shell displays your command prompt and waits for you to type your first command. Just before it does that, however, your login shell executes two special files on the system. The first is `/etc/profile`. This file is set up by the system administrator and usually does things like checking to see whether you have mail (Where do you think the "You have mail." message comes from?), setting your default file creation mask (your `umask`), assigning values to some standard exported variables, and anything else that the administrator wants to have executed whenever a user logs in.

The second file that gets automatically executed is `.profile` in your home directory. Your system administrator may have given you a default `.profile` file when you got your account. See what's in it now:

```
$ cat $HOME/.profile

PATH="/bin:/usr/bin:/usr/sbin:."

export PATH

$
```

Here you see a small `.profile` file that simply sets the `PATH` and exports it.

You can change your `.profile` file to include any commands that you want executed whenever you log in. You can even put commands in your `.profile` file that override settings (usually environment variables) made in `/etc/profile`. Note that the commands in `/etc/profile` and `.profile` are executed by your login shell (as if you typed in

```
$ . /etc/profile

$ . .profile

$
```

as soon as you logged in), which means that changes made to your environment remain after the programs are executed.

Here's a sample `.profile` that sets your `PATH` to include your own `bin`, sets your `CDPATH`, changes your primary and secondary command prompts, changes your erase character to a backspace (`Ctrl+h`) with the `stty` command, and prints a friendly message using the `greetings` program from

## [Chapter 8](#), "Decisions, Decisions":

```
$ cat $HOME/.profile

PATH=/bin:/usr/bin:/usr/sbin:$HOME/bin:.:

CDPATH=.:$HOME:$HOME/misc:$HOME/documents

PS1="=> "

PS2="====> "

export PATH CDPATH PS1 PS2

stty echoe erase CTRL+h

echo

greetings

$
```

Here's what a login sequence would look like with this `.profile`:

```
login: steve
```

```
Password:
```

```
Good morning
```

```
Output from greetings
```

```
=>
```

```
New PS1
```

## The `TERM` Variable

If you tend to use more than one type of terminal, the `.profile` is a good place to put some code to prompt for the terminal type and then set the `TERM` variable accordingly. This variable is used by screen editors such as `vi` and other screen-based programs.

A sample section of code from a `.profile` file to prompt for the terminal type might look like this:

```
echo "What terminal are you using (xterm is the default)? \c"

read TERM

if [ -z "$TERM" ]

then

    TERM=xterm

fi

export TERM
```

Based on the terminal type entered, you may also want to do things such as set up the function keys or the tabs on the terminal.

Even if you always use the same terminal type, you should set the `TERM` variable in your `.profile` file.

## The `TZ` Variable

The `TZ` variable is used by the `date` command and some Standard C library functions to determine time zone information. The simplest setting for `TZ` is a time zone name of three or more alphabetic characters followed by a number that specifies the number of hours that must be added to the local time to arrive at *Coordinated Universal Time*, also known as Greenwich Mean Time. This number can be positive (local time zone is west of 0 longitude) or negative (local time zone is east of 0 longitude). For example, Eastern Standard Time can be specified as

```
TZ=EST5
```

The `date` command calculates the correct time based on this information and also uses the time zone name in its output:

```
$ TZ=EST5 date
```

```
Wed Sep 18 15:24:09 EST 2002
```

```
$ TZ=xyz3 date
```

```
Wed Sep 18 17:24:28 xyz 2002
```

```
$
```

A second time zone name can follow the number; if this time zone is specified, daylight savings time is assumed to apply (`date` automatically adjusts the time in this case when daylight saving is in effect) and is assumed to be one hour earlier than standard time. If a number follows the daylight saving time zone name, this value is used to compute the daylight savings time from the Coordinated Universal Time in the same way as the number previously described.

So, the following `TZ` settings are equivalent:

```
TZ=EST5EDT
```

```
TZ=EST5EDT6
```

The `TZ` variable is usually set in either the `/etc/profile` file or your `.profile` file. If not set, an

implementation-specific default time zone is used, typically Coordinated Universal Time.

**Team LiB**

[◀ PREVIOUS](#)

[NEXT ▶](#)

## Exercises

- 1: Write a program called `myrm` that takes as arguments the names of files to be removed. If the global variable `MAXFILES` is set, take it as the maximum number of files to remove without question. If the variable is not set, use 10 as the maximum. If the number of files to be removed exceeds this count, ask the user for confirmation before removing the files:

```
$ ls | wc -l
```

```
25
```

```
$ myrm * Remove them all
```

```
Remove 25 files (y/n)? n
```

```
files not removed
```

```
$ MAXFILES=100 myrm *
```

```
$ ls
```

```
$ All files removed
```

If `MAXFILES` is set to zero, the check should be suppressed.

- 2: Here are two programs called `prog1` and `prog2`:

```
$ cat prog1
```

```
e1=100
```

```
export e1
```

```
e2=200
```

```
e3=300 prog2
```

```
$ cat prog2
```

```
echo $e1 $e2 $e3 $e4
```



```
$
```

What output would you expect after typing the following:

```
$ e2=20; export e2
```

```
$ e4=40 prog1
```

- 3: Modify `rolo` from this chapter so that a person running the program can keep his or her phone book file in any directory and not just in the home directory. This can be done by requiring that the user set an exported variable called `PHONEBOOK` to the name of the phone book file before executing `rolo`. Check to make sure that this variable is set to a valid file. If the variable is not set, have the program assume that the phone book file is in the user's home directory as before.

Here are some examples:

```
$ PHONEBOOK=/users/steve/personal lu Gregory
```

```
Gregory          973-555-0370
```

```
$ PHONEBOOK=/users/pat/phonebook lu Toritos
```

```
El Toritos      973-555-2236
```

```
$
```

In the preceding example, we assume that the user `steve` has been granted read access to `pat`'s phone book file.

# Chapter 12. More on Parameters

## IN THIS CHAPTER

- [Parameter Substitution](#)
- [The \\$0 Variable](#)
- [The set Command](#)
- [The IFS Variable](#)
- [The readonly Command](#)
- [The unset Command](#)
- [Exercises](#)

In this chapter, you'll learn some more about parameters. Technically, parameters include the arguments passed to a program (the *positional* parameters), the special shell variables such as `$#` and `$?`, and ordinary variables, also known as *keyword* parameters.

Positional parameters cannot be assigned values directly; however, they can be reassigned values with the `set` command. Keyword parameters are assigned values simply by writing

```
variable=value
```

The format is a bit more general than that shown; actually, you can assign several keyword parameters at once using the format

```
variable=value variable=value ...
```

as the following example illustrates:

```
$ x=100 y=200 z=50
```

```
$ echo $x $y $z
```

100 200 50

\$

**Team LiB**

**◀ PREVIOUS**

**NEXT ▶**

## Parameter Substitution

In the simplest form, to have the value of a parameter substituted, you simply precede the parameter with a dollar sign, as in `$i` or `$9`.

### `${parameter}`

If there's a potential conflict caused by the characters that follow the parameter name, you can enclose the name inside curly braces, as in

```
mv $file ${file}x
```

This command would add an `x` to the end of the filename specified by `$file` and could not be written as

```
mv $file $filex
```

because the shell would substitute the value of `filex` for the second argument.

As mentioned in [Chapter 7](#), "Passing Arguments," to access positional parameters 10 and above, you must enclose the number inside the curly braces, as in `${11}`.

### `${parameter:-value}`

This construct says to substitute the value of *parameter* if it is not null, and to substitute *value* otherwise. For example, in the command line

```
echo Using editor ${EDITOR:-/bin/vi}
```

the shell substitutes the value of `EDITOR` if it's not null, and the value `/bin/vi` otherwise. It has the same effect as writing

```
if [ -n "$EDITOR" ]
then
    echo Using editor $EDITOR
else
    echo Using editor /bin/vi
fi
```

The command line

```
${EDITOR:-/bin/ed} /tmp/edfile
```

starts up the program stored in the variable `EDITOR` (presumably a text editor), or `/bin/ed` if `EDITOR` is null.

Here's a simple test of this construct from the terminal:

```
$ EDITOR=/bin/ed
$ echo ${EDITOR:-/bin/vi}
/bin/ed
$ EDITOR=                Set it null
$ echo ${EDITOR:-/bin/vi}
/bin/vi
$
```

### **`${parameter:=value}`**

This version is similar to the last, only if *parameter* is null; not only is *value* used, but it is also assigned to *parameter* as well (note the `=` in the construct). You can't assign values to positional parameters this way (that means that *parameter* can't be a number).

A typical use of this construct would be in testing to see whether an exported variable has been set and, if not, setting it to a default value, as in

```
 ${PHONEBOOK:=${HOME}/phonebook}
```

This says that if `PHONEBOOK` is set to some value, leave it alone; otherwise, set it to `HOME/phonebook`.

Note that the preceding example could not stand alone as a command because after the substitution was performed the shell would attempt to execute the result:

```
 $ PHONEBOOK=
 $ ${PHONEBOOK:=${HOME}/phonebook}
 sh: /users/steve/phonebook: cannot execute
 $
```

To use this construct as a standalone command, the null command is often employed. If you write

```
 : ${PHONEBOOK:=${HOME}/phonebook}
```

the shell still does the substitution (it evaluates the rest of the command line), yet executes nothing (the null command).

```
 $ PHONEBOOK=
 $ : ${PHONEBOOK:=${HOME}/phonebook}
 $ echo $PHONEBOOK                               See if it got assigned
 /users/steve/phonebook
 $ : ${PHONEBOOK:=foobar}                         Shouldn't change it
 $ echo $PHONEBOOK
 /users/steve/phonebook                           It didn't
```

\$

## **`${parameter:?value}`**

If *parameter* is not null, the shell substitutes its value; otherwise, the shell writes *value* to standard error and then exits (don't worry—if it's done from your login shell, you won't be logged off). If *value* is omitted, the shell writes the message

```
prog: parameter: parameter null or not set
```

Here's an example from the terminal:

```
$ PHONEBOOK=
```

```
$ : ${PHONEBOOK:? "No PHONEBOOK file!"}
```

```
No PHONEBOOK file!
```

```
$ : ${PHONEBOOK:?}           Don't give a value
```

```
sh: PHONEBOOK: parameter null or not set
```

```
$
```

With this construct, you can easily check to see whether a set of variables needed by a program are all set and not null, as in

```
: ${TOOLS:?}  ${EXPTOOLS:?}  ${TOOLBIN:?}
```

## **`${parameter:+value}`**

This one substitutes *value* if *parameter* is not null; otherwise, it substitutes nothing.

```
$ traceopt=T
```

```
$ echo options: ${traceopt:+"trace mode"}
options: trace mode

$ traceopt=

$ echo options: ${traceopt:+"trace mode"}
options:

$
```

The *value* part for any of the constructs in this section can be a command substitution; it's executed by the shell only if its value is to be used. In

```
WORKDIR=${DBDIR:-$(pwd)}
```

`WORKDIR` is assigned the value of `DBDIR` if it's not null; otherwise, the `pwd` command is executed and the result assigned to `WORKDIR`. `pwd` is executed *only if* `DBDIR` is null.

## Pattern Matching Constructs

The POSIX standard shell provides four parameter substitution constructs that perform pattern matching. Note that some older shells do not support this feature.

In each case, the construct takes two arguments: a variable name (or parameter number) and a pattern. The shell searches through the contents of the specified variable to match the supplied pattern. If the pattern is matched, the shell substitutes the value of the variable on the command line, *with the matching portion of the pattern deleted*. If the pattern is not matched, the entire contents of the variable are substituted on the command line. In any case, the contents of the variable remain unchanged.

The term *pattern* is used here because the shell allows you to use the same pattern matching characters that it accepts in filename substitution and `case` values: `*` to match zero or more characters, `?` to match any single character, `[...]` to match any single character from the specified set, and `[!...]` to match any single character not in the specified set.

When you write the construct

```
${variable%pattern}
```



the shell looks inside *variable* to see whether it *ends* with the specified *pattern*. If it does, the contents of *variable* are substituted on the command line with the shortest matching *pattern* removed from the right.

If you use the construct

```
${variable%%pattern}
```

the shell once again looks inside *variable* to see whether it ends with *pattern*. This time, however, it removes the *longest* matching pattern from the right. This is relevant only if the *\** is used in *pattern*. Otherwise, the *%* and *%%* behave the same way.

The *#* is used in a similar way to force the pattern matching to occur on the left rather than the right. So, the construct.

```
${variable#pattern}
```

tells the shell to substitute the value of *variable* on the command line, with *pattern* removed from the left.

Finally, the shell construct

```
${variable##pattern}
```

works like the *#* form, only the longest occurrence of *pattern* is removed from the left.

Remember that in all four cases, no permanent changes are made to the variable itself; you are affecting only what gets substituted on the command line. Also, remember that the pattern matches are *anchored*. In the case of the *%* and *%%* constructs, the variables must *end* with the specified pattern; in the case of the *#* and *##* constructs, the variable must *begin* with it.

Here are some simple examples to show how these constructs work:

```
$ var=testcase
```

```
$ echo $var
```

```
testcase
```

```

$ echo ${var%e}           Remove e from right
testcas

$ echo $var              Variable is unchanged
testcase

$ echo ${var%s*e}       Remove smallest match from right
testca

$ echo ${var%%s*e}      Remove longest match
te

$ echo ${var#?e}        Remove smallest match from left
stcase

$ echo ${var#*s}        Remove smallest match from left
tcase

$ echo ${var##*s}       Remove longest match from left
e

$ echo ${var#test}     Remove test from left
case

$ echo ${var#teas}     No match
testcase

$

```

There are many practical uses for these constructs, even though these examples don't seem to show it. For example, the following tests to see whether the filename stored inside the variable `file` ends in the two characters `.o`:

```

if [ ${file%.o} != $file ]
then
    # file ends in .o

```

...

fi

As another example, here's a shell program that works just like the Unix system's `basename` command:

```
$ cat mybasename
```

```
echo ${1##*/}
```

```
$
```

The program displays its argument with all the characters up to the last `/` removed:

```
$ mybasename /usr/spool/uucppublic
```

```
uucppublic
```

```
$ mybasename $HOME
```

```
steve
```

```
$ mybasename memos
```

```
memos
```

```
$
```

### **`${#variable}`**

This construct gives you the ability to count the number of characters stored inside a variable. For example,

```
$ text='The shell'
```

```
$ echo ${#text}
```

```
9
```

\$

Note that some older shells do not support this feature.

Each of the parameter substitution constructs described in this section is summarized in [Table A.3](#) in [Appendix A](#), "Shell Summary."

**Team LiB**

◀ PREVIOUS

NEXT ▶

## The \$0 Variable

Whenever you execute a shell program, the shell automatically stores the name of the program inside the special variable `$0`. This can be used to advantage when you have two or more programs that are linked under different names and you want to know which one was executed. It's also useful for displaying error messages because it removes the dependency of the filename from the program. If the name of the program is referenced by `$0`, subsequently renaming the program will not require the program to be edited:

```
$ cat lu

#
# Look someone up in the phone book
#

if [ "$#" -ne 1 ]
then
    echo "Incorrect number of arguments"
    echo "Usage: $0 name"
    exit 1
fi

name=$1
grep "$name" $PHONEBOOK

if [ $? -ne 0 ]
then
    echo "I couldn't find $name in the phone book"
fi
```

```
$ PHONEBOOK=$HOME/phonebook
```

```
$ export PHONEBOOK
```

```
$ lu Teri
```

```
Teri Zak          201-555-6000
```

```
$ lu Teri Zak
```

```
Incorrect number of arguments
```

```
Usage: lu name
```

```
$ mv lu lookup
```

*Rename it*

```
$ lookup Teri Zak
```

*See what happens now*

```
Incorrect number of arguments
```

```
Usage: lookup name
```

```
$
```

## The `set` Command

The shell's `set` command is a dual-purpose command: it's used both to set various shell options as well as to reassign the positional parameters `$1`, `$2`, and so forth.

### The `-x` Option

This option turns on trace mode in the shell. It does to the current shell what the command

```
sh -x ctype a
```

did for the execution of the `ctype` program in [Chapter 8](#), "Decisions, Decisions." From the point that the

```
set -x
```

command is executed, all subsequently executed commands will be printed to standard error by the shell, after filename, variable, and command substitution and I/O redirection have been performed. The traced commands are preceded by plus signs.

```
$ x=*
```

```
$ set -x                               Set command trace option
```

```
$ echo $x
```

```
+ echo add greetings lu rem rolo
```

```
add greetings lu rem rolo
```

```
$ cmd=wc
```

```
+ cmd=wc
```

```
$ ls | $cmd -l
```

```
+ ls
```

```
+ wc -l
      5
$
```

You can turn off trace mode at any time simply by executing `set` with the `+x` option:

```
$ set +x
+ set +x
$ ls | wc -l
      5          Back to normal
$
```

You should note that the trace option is *not* passed down to subshells. But you can trace a subshell's execution either by running the shell with the `-x` option followed by the name of the program to be executed, as in

```
sh -x rolo
```

or you can insert a `set -x` command inside the file itself. In fact, you can insert any number of `set -x` and `set +x` commands inside your program to turn trace mode on and off as desired.

## `set` with No Arguments

If you don't give any arguments to `set`, you'll get an alphabetized list of all the variables that exist in your environment, be they local or exported:

```
$ set          Show me all variables
CDPATH=:/users/steve:/usr/spool
EDITOR=/bin/vi
```



```
HOME=/users/steve
IFS=

LOGNAME=steve

MAIL=/usr/spool/mail/steve

MAILCHECK=600

PATH=/bin:/usr/bin:/users/steve/bin:.:

PHONEBOOK=/users/steve/phonebook

PS1=$

PS2=>

PWD=/users/steve/misc

SHELL=/usr/bin/sh

TERM=xterm

TMOUT=0

TZ=EST5EDT

cmd=wc

x=*

$
```

## Using `set` to Reassign Positional Parameters

There is no way to directly assign a value to a positional parameter; for example,

```
1=100
```

does not work. These parameters are initially set on execution of the shell program. The only way they may be changed is with the `shift` or the `set` commands. If words are given as arguments to `set` on the command line, those words will be assigned to the positional parameters `$1`, `$2`, and so

forth. The previous values stored in the positional parameters will be lost forever. So

```
set a b c
```

assigns `a` to `$1`, `b` to `$2`, and `c` to `$3`. `$#` also gets set to 3.

```
$ set one two three four
```

```
$ echo $1:$2:$3:$4
```

```
one:two:three:four
```

```
$ echo $#
```

*This should be 4*

```
4
```

```
$ echo $*
```

*What does this reference now?*

```
one two three four
```

```
$ for arg; do echo $arg; done
```

```
one
```

```
two
```

```
three
```

```
four
```

```
$
```

So after execution of the `set`, everything seems to work consistently: `$#`, `$*`, and the `for` loop without a list.

`set` is often used in this fashion to "parse" data read from a file or the terminal. Here's a program called `words` that counts the number of words typed on a line (using the shell's definition of a "word"):

```
$ cat words
```

```
#
```

```
# Count words on a line

#

read line

set $line

echo $#

$ words                               Run it

Here's a line for you to count.

7

$
```

The program stores the line read in the shell variable `line` and then executes the command

```
set $line
```

This causes each word stored in `line` to be assigned to the positional parameters. The variable  `$#`  is also set to the number of words assigned, which is the number of words on the line.

## The -- Option

Try typing in a line to `words` that begins with a `-` and see what happens:

```
$ words

-1 + 5 = 4

words: -1: bad option(s)

$
```

After the line was read and assigned to `line`, the command

```
set $line
```

was executed. After the shell did its substitution, the command line looked like this:

```
set -1 + 5 = 4
```

When `set` executed, it saw the `-` and thought that an option was being selected, thus explaining the error message.

Another problem with `words` occurs if you give it a line consisting entirely of whitespace characters, or if the line is null:

```
$ words
```

*Just Enter is pressed*

```
CDPATH=.: /users/steve:/usr/spool
```

```
EDITOR=/bin/vi
```

```
HOME=/users/steve
```

```
IFS=
```

```
LOGNAME=steve
```

```
MAIL=/usr/spool/mail/steve
```

```
MAILCHECK=600
```

```
PATH=/bin:/usr/bin:/users/steve/bin:.
```

```
PHONEBOOK=/users/steve/phonebook
```

```
PS1=$
```

```
PS2=>
```

```
PWD=/users/steve/misc
```

```
SHELL=/usr/bin/sh
```

```
TERM=xterm
```

```
TMOUT=0
```

```
TZ=EST5EDT
```

```
cmd=wc
```

```
x=*
```

```
0
```

```
$
```

To protect against both of these problems occurring, you can use the `--` option to `set`. This tells `set` not to interpret any subsequent arguments on the command line as options. It also prevents `set` from displaying all your variables if no other arguments follow, as was the case when you typed a null line.

So the `set` command in `words` should be changed to read

```
set -- $line
```

With the addition of a `while` loop and some integer arithmetic, the `words` program can be easily modified to count the total number of words on standard input, giving you your own version of `wc -w`:

```
$ cat words
```

```
#
```

```
# Count all of the words on standard input
```

```
#
```

```
count=0
```

```
while read line
```

```
do
```

```
    set -- $line
```

```
        count=$(( count + $# ))
done

echo $count

$
```

After each line is read, the `set` command is executed to take advantage of the fact that `$#` will be assigned the number of words on the line. The `--` option is supplied to `set` just in case any of the lines read begins with a `-` or consists entirely of whitespace characters.

The value of `$#` is then added into the variable `count`, and the next line is read. When the loop is exited, the value of `count` is displayed. This represents the total number of words read.

```
$ words < /etc/passwd
567

$ wc -w < /etc/passwd          Check against wc
567

$
```

(Our version is a lot slower than `wc` because the latter is written in C.)

Here's a quick way to count the number of files in your directory: [\[1\]](#)

<sup>[1]</sup> *This technique may not work on very large directories because you may exceed the limit on the length of the command line (the precise length varies between Unix systems). Working with such directories may cause problems when using filename substitution in other commands as well, such as `echo *` or `for file in *`.*

```
$ set *
$ echo $#
8
$
```

This is much faster than

```
ls | wc -l
```

because the first method uses only shell built-in commands. In general, your shell programs run much faster if you try to get as much done as you can using the shell's built-in commands.

## Other Options to `set`

`set` accepts several other options, each of them enabled by preceding the option with a `-`, and disabled by preceding it with a `+`. The `-x` option that we have described here is perhaps the most commonly used. Others are summarized in [Table A.9](#) in [Appendix A](#).

Team LiB

◀ PREVIOUS

NEXT ▶

## The `IFS` Variable

There is a special shell variable called `IFS`, which stands for *I*nternal *F*ield *S*eparator. The shell uses the value of this variable when parsing input from the `read` command, output from command substitution (the back-quoting mechanism), and when performing variable substitution. If it's typed on the command line, the shell treats it like a normal whitespace character (that is, as a word delimiter).

See what it's set to now:

```
$ echo "$IFS"
```

```
$
```

Well, that wasn't very illuminating! To determine the actual characters stored in there, pipe the output from `echo` into the `od` (*o*ctal *d*ump) command with the `-b` (byte display) option:

```
$ echo "$IFS" | od -b
0000000 040 011 012 012
0000004
$
```

The first column of numbers shown is the relative offset from the start of the input. The following numbers are the octal equivalents of the characters read by `od`. The first such number is `040`, which is the ASCII value of the space character. It's followed by `011`, the tab character, and then by `012`, the newline character. The next character is another newline; this was written by the `echo`. These characters for `IFS` come as no surprise; they're the "whitespace" characters we've talked about throughout the book.

You can change your `IFS` to any character or characters you want. This is useful when you want to parse a line of data whose fields aren't delimited by the normal whitespace characters. For example, we noted that the shell normally strips any leading whitespace characters from the beginning of any line that you read with the `read` command. You can change your `IFS` to just a newline character before the `read` is executed, which has the effect of preserving the leading whitespace (because the



shell won't consider it a field delimiter):

```
$ read line                                Try it the "old" way

    Here's a line

$ echo "$line"

Here's a line

$ IFS=""

> "                                         Set it to a just a newline

$ read line                                Try it again

    Here's a line

$ echo "$line"

    Here's a line                            Leading spaces preserved

$
```

To change the `IFS` to just a newline, an open quote was typed, followed immediately by the pressing of the Enter key, followed by the closed quote on the next line. No additional characters can be typed inside those quotes because they'll be stored inside `IFS` and then used by the shell.

Now let's change the `IFS` to something more visible, like a colon:

```
$ IFS=:

$ read x y z

123:345:678

$ echo $x

123

$ echo $z

678

$ list="one:two:three"
```

```
$ for x in $list; do echo $x; done
```

```
one
```

```
two
```

```
three
```

```
$ var=a:b:c
```

```
$ echo "$var"
```

```
a:b:c
```

```
$
```

Because the `IFS` was changed to a colon, when the line was read, the shell divided the line into three words: `123`, `345`, and `678`, which were stored into the three variables `x`, `y`, and `z`, respectively. In the next to last example, the shell used the `IFS` when substituting the value of `list` in the `for` loop. The last example shows that the shell doesn't use the `IFS` when performing variable assignment.

Changing the `IFS` is often done in conjunction with execution of the `set` command:

```
$ line="Micro Logic Corp.:Box 174:Hackensack, NJ 07602"
```

```
$ IFS=:
```

```
$ set $line
```

```
$ echo $# How many parameters were set?
```

```
3
```

```
$ for field; do echo $field; done
```

```
Micro Logic Corp.
```

```
Box 174
```

```
Hackensack, NJ 07602
```

```
$
```

This technique is a powerful one; it uses all built-in shell commands, which also makes it very fast. (An alternative approach might have been to `echo` the value of `$line` into the `tr` command, where all colons could have been translated into newlines, an approach that would have been much slower.)

This technique is used in a final version of the `rolo` program that's presented in [Chapter 14](#), "Rolo Revisited."

The following program, called `number2`, is a final version of the line numbering program presented in [Chapter 10](#), "Reading and Printing Data." This program faithfully prints the input lines to standard output, preceded by a line number. Notice the use of `printf` to right-align the line numbers.

```
$ cat number2

#
# Number lines from files given as argument or from
# standard input if none supplied (final version)
#

# Modify the IFS to preserve leading whitespace on input

IFS='
' # Just a newline appears between the quotes

lineno=1

cat $* |
while read -r line
do
    printf "%5d:%s\n" $lineno "$line"
    lineno=$(( lineno + 1 ))
done
```

Here's a sample execution of `number`:

```
$ number2 words

1:#

2:# Count all of the words on standard input

3:#

4:

5:count=0

6:while read line

7:do

8:  set -- $line

9:  count=$(( count + $# ))

10:done

11:

12:echo $count

$
```

Because the `IFS` has an influence on the way things are interpreted by the shell, if you're going to change it in your program, it's usually wise to save the old value first in another variable (such as `OIFS`) and then restore it after you've finished the operations that depend on the changed `IFS`.

## The `readonly` Command

The `readonly` command is used to specify variables whose values cannot be subsequently changed. For example,

```
readonly PATH HOME
```

makes the `PATH` and `HOME` variables read-only. Subsequently attempting to assign a value to these variables causes the shell to issue an error message:

```
$ PATH=/bin:/usr/bin:.  
$ readonly PATH  
$ PATH=$PATH:/users/steve/bin  
sh: PATH: is read-only  
$
```

Here you see that after the variable `PATH` was made read-only, the shell printed an error message when an attempt was made to assign a value to it.

To get a list of your read-only variables, type `readonly -p` without any arguments: [\[2\]](#)

<sup>[2]</sup> By default, Bash produces output of the form `declare -r variable`. To get POSIX-compliant output, you must run Bash with the `-posix` command-line option or run the `set` command with the `-o posix` option.

```
$ readonly -p  
readonly PATH=/bin:/usr/bin:.  
$
```

`unset` removes both exported and local shell variables.

You should be aware of the fact that the read-only variable attribute is not passed down to subshells.

Also, after a variable has been made read-only in a shell, there is no way to "undo" it.

**Team LiB**

[◀ PREVIOUS](#)

[NEXT ▶](#)

## The `unset` Command

Sometimes you may want to remove the definition of a variable from your environment. To do so, you type `unset` followed by the names of the variables:

```
$ x=100
$ echo $x
100
$ unset x           Remove x from the environment
$ echo $x

$
```

You can't `unset` a read-only variable. Furthermore, the variables `IFS`, `MAILCHECK`, `PATH`, `PS1`, and `PS2` cannot be `unset`. Also, some older shells do not support the `unset` command.

# Exercises

- 1: Given the following variable assignments:

```
$ EDITOR=/bin/vi
```

```
$ DB=
```

```
$ EDITFLAG=yes
```

```
$ PHONEBOOK=
```

```
$
```

What will be the results of the following commands?

```
echo ${EDITOR}
```

```
echo ${DB:=/users/pat/db}
```

```
echo ${EDITOR:-/bin/ed}
```

```
echo ${PHONEBOOK:?}
```

```
echo ${DB:-/users/pat/db}
```

```
ed=${EDITFLAG:+${EDITOR:-/bin/ed}}
```

- 2: Rewrite the `home` program from Exercise 5 in [Chapter 7](#) to use the `set` command and the `IFS` to extract the home directory from `/etc/passwd`. What happens to the program if one of the fields in the file is null, as in

```
steve:*:203:100::/users/steve:/usr/bin/ksh
```

Here the fifth field is null (`::`).

- 3: Using the fact that the shell construct `${#var}` gives the number of characters stored in `var`, rewrite `wc` in the shell. Be sure to use integer arithmetic! (Notes: Change your `IFS` variable to just a newline character so that leading whitespace characters on input are preserved, and also use the `-r` option to the shell's `read` command so that terminating backslash characters on the input are ignored.)



- 4: Write a function called `rightmatch` that takes two arguments as shown:

```
rightmatch value pattern
```

where *value* is a sequence of one or more characters, and *pattern* is a shell pattern that is to be removed from the right side of *value*. The *shortest* matching pattern should be removed from *value* and the result written to standard output. Here is some sample output:

```
$ rightmatch test.c .c
test

$ rightmatch /usr/spool/uucppublic '/*'
/usr/spool

$ rightmatch /usr/spool/uucppublic o
/usr/spool/uucppublic

$
```

The last example shows that the `rightmatch` function should simply echo its first argument if it does not end with the specified pattern.

- 5: Write a function called `leftmatch` that works similarly to the `rightmatch` function developed in Exercise 4. Its two arguments should be as follows:

```
leftmatch pattern value
```

Here are some example uses:

```
$ leftmatch /usr/spool/ /usr/spool/uucppublic
uucppublic

$ leftmatch s. s.main.c
main.c
```

\$

- 6: Write a function called `substring` that uses the `leftmatch` and `rightmatch` functions developed in Exercises 4 and 5 to remove a pattern from the left and right side of a value. It should take three arguments as shown:

```
$ substring /usr/ /usr/spool/uucppublic /uucppublic
```

```
spool
```

```
$ substring s. s.main.c .c
```

```
main
```

```
$ substring s. s.main.c .o           Only left match
```

```
main.c
```

```
$ substring x. s.main.c .o           No matches
```

```
s.main.c
```

```
$
```

- 7: Modify the `substring`, `leftmatch`, and `rightmatch` functions developed in the previous exercises to take options that allow you to remove the *largest* possible matches of the specified pattern from the left or right side of the specified value.

# Chapter 13. Loose Ends

## IN THIS CHAPTER

- [The `eval` Command](#)
- [The `wait` Command](#)
- [The `trap` Command](#)
- [More on I/O](#)
- [Functions](#)
- [The `type` Command](#)
- [Exercises](#)

We've put commands and features into this chapter that for one reason or another did not logically fit into earlier chapters. There's no particular rationale for their order of presentation.

## The `eval` Command

This section describes another of the more unusual commands in the shell: `eval`. Its format is as follows:

```
eval command-line
```

where *command-line* is a normal command line that you would type at the terminal. When you put `eval` in front of it, however, the net effect is that the shell scans the command line *twice* before executing it.<sup>[1]</sup> For the simple case, this really has no effect:

<sup>[1]</sup> Actually, what happens is that `eval` simply executes the command passed to it as arguments; so the shell processes the command line when passing the arguments to `eval`, and then once again when `eval` executes the command. The net result is that the command line is scanned twice by the shell.

```
$ eval echo hello
```

```
hello
```

```
$
```

But consider the following example without the use of `eval`:

```
$ pipe="|"
```

```
$ ls $pipe wc -l
```

```
|: No such file or directory
```

```
wc: No such file or directory
```

```
-l: No such file or directory
```

```
$
```

Those errors come from `ls`. The shell takes care of pipes and I/O redirection *before* variable substitution, so it never recognizes the pipe symbol inside `pipe`. The result is that the three

arguments `|`, `wc`, and `-l` are passed to `ls` as arguments.

Putting `eval` in front of the command sequence gives the desired results:

```
$ eval ls $pipe wc -l
```

```
16
```

```
$
```

The first time the shell scans the command line, it substitutes `|` as the value of `pipe`. Then `eval` causes it to rescan the line, at which point the `|` is recognized by the shell as the pipe symbol.

The `eval` command is frequently used in shell programs that build up command lines inside one or more variables. If the variables contain any characters that must be seen by the shell directly on the command line (that is, not as the result of substitution), `eval` can be useful. Command terminator (`;`, `|`, `&`), I/O redirection (`<`, `>`), and quote characters are among the characters that must appear directly on the command line to have any special meaning to the shell.

For the next example, consider writing a program `last` whose sole purpose is to display the last argument passed to it. You needed to get at the last argument in the `mycp` program in [Chapter 10](#), "Reading and Printing Data." There you did so by shifting all the arguments until the last one was left. You can also use `eval` to get at it as shown:

```
$ cat last
```

```
eval echo \$$#
```

```
$ last one two three four
```

```
four
```

```
$ last * Get the last file
```

```
zoo_report
```

```
$
```

The first time the shell scans

```
echo \$$#
```

the backslash tells it to ignore the `$` that immediately follows. After that, it encounters the special parameter `$#`, so it substitutes its value on the command line. The command now looks like this:

```
echo $4
```

(the backslash is removed by the shell after the first scan). When the shell rescans this line, it substitutes the value of `$4` and then executes `echo`.

This same technique could be used if you had a variable called `arg` that contained a digit, for example, and you wanted to display the positional parameter referenced by `arg`. You could simply write

```
eval echo \$$arg
```

The only problem is that just the first nine positional parameters can be accessed this way; to access positional parameters 10 and greater, you must use the `${n}` construct:

```
eval echo \${$arg}
```

Here's how the `eval` command can be used to effectively create "pointers" to variables:

```
$ x=100
```

```
$ ptrx=x
```

```
$ eval echo \$$ptrx           Dereference ptrx
```

```
100
```

```
$ eval $ptrx=50              Store 50 in var that ptrx points to
```

```
$ echo $x                    See what happened
```

```
50
```

```
$
```



## The `wait` Command

If you submit a command line to the background for execution, that command line runs in a subshell independent of your current shell (the job is said to run *asynchronously*). At times, you may want to wait for the background process (also known as a *child* process because it's spawned from your current shell—the *parent*) to finish execution before proceeding. For example, you may have sent a large `sort` into the background and now want to wait for the `sort` to finish because you need to use the sorted data.

The `wait` command is for such a purpose. Its general format is

```
wait process-id
```

where *process-id* is the process id number of the process you want to wait for. If omitted, the shell waits for all child processes to complete execution. Execution of your current shell will be suspended until the process or processes finish execution. You can try the `wait` command at your terminal:

```
$ sort big-data > sorted_data &           Send it to the background  
  
[1] 3423                                Job number & process id from the shell  
  
$ date                                   Do some other work  
  
Wed Oct  2 15:05:42 EDT 2002  
  
$ wait 3423                              Now wait for the sort to finish  
  
$                                       When sort finishes, prompt is returned
```

## The `$_` Variable

If you have only one process running in the background, then `wait` with no argument suffices. However, if you're running more than one command in the background and you want to wait on a particular one, you can take advantage of the fact that the shell stores the process id of the last command executed in the background inside the special variable `$_`. So the command

```
wait $_
```



waits for the last process sent to the background to complete execution. As mentioned, if you send several commands to the background, you can save the value of this variable for later use with `wait`:

```
prog1 &
pid1=$!
...
prog2 &
pid2=$!
...
wait $pid1          # wait for prog1 to finish
...
wait $pid2          # wait for prog2 to finish
```

## The `trap` Command

When you press the Delete<sup>[2]</sup> or Break key at your terminal during execution of a shell program, normally that program is immediately terminated, and your command prompt returned. This may not always be desirable. For instance, you may end up leaving a bunch of temporary files that won't get cleaned up.

<sup>[2]</sup> *Some Unix systems use `Ctrl+c` rather than the Delete key for this purpose. You can determine which key sequence is used with the `stty` command.*

The pressing of the Delete key at the terminal sends what's known as a *signal* to the executing program. The program can specify the action that should be taken on receipt of the signal. This is done with the `trap` command, whose general format is

```
trap commands signals
```

where *commands* is one or more commands that will be executed whenever any of the signals specified by *signals* is received.

Numbers are assigned to the different types of signals, and the more commonly used ones are summarized in [Table 13.1](#). A more complete list is given under the `trap` command in [Appendix A](#), "Shell Summary."

Table 13.1. Commonly Used Signal Numbers

Signal	Generated for
0	Exit from the shell
1	Hangup
2	Interrupt (for example, Delete, <i>Ctrl+c</i> key)
15	Software termination signal (sent by <code>kill</code> by default)

As an example of the `trap` command, the following shows how you can remove some files and then exit if someone tries to abort the program from the terminal:

```
trap "rm $WORKDIR/work1$$ $WORKDIR/dataout$$; exit" 2
```

From the point in the shell program that this `trap` is executed, the two files `work1$$` and `dataout$$` will be automatically removed if signal number 2 is received by the program. So if the user interrupts execution of the program after this `trap` is executed, you can be assured that these two files will be cleaned up. The `exit` that follows the `rm` is necessary because without it execution would continue in the program at the point that it left off when the signal was received.

Signal number 1 is generated for hangup: Either someone intentionally hangs up the line or the line gets accidentally disconnected. You can modify the preceding `trap` to also remove the two specified files in this case by adding signal number 1 to the list of signals:

```
trap "rm $WORKDIR/work1$$ $WORKDIR/dataout$$; exit" 1 2
```

Now these files will be removed if the line gets hung up or if the Delete key gets pressed.

The commands specified to `trap` must be enclosed in quotes if they contain more than one command. Also note that the shell scans the command line at the time that the `trap` command gets executed and also again when one of the listed signals is received. So in the preceding example, the value of `WORKDIR` and `$$` will be substituted at the time that the `trap` command is executed. If you wanted this substitution to occur at the time that either signal 1 or 2 was received (for example, `WORKDIR` may not have been defined yet), you can put the commands inside single quotes:

```
trap 'rm $WORKDIR/work1$$ $WORKDIR/dataout$$; exit' 1 2
```

The `trap` command can be used to make your programs more user friendly. In the next chapter, when we revisit the [rolo](#) program, the signal generated by the Delete key is caught by the program and brings the user back to the main menu. In this way, this key can be used to abort the current operation without exiting from the program.

## `trap` with No Arguments

Executing `trap` with no arguments results in the display of any traps that you have changed.

```
$ trap 'echo logged off at $(date) >>$HOME/logoffs' 0
$ trap                               List changed traps
trap - 'echo logged off at $(date) >>$HOME/logoffs' EXIT
$ Ctrl+d                               Log off
login: steve                           Log back in
```

Password:

```
$ cat $HOME/logoffs           See what happened
```

```
logged off at Wed Oct  2 15:11:58 EDT 2002
```

```
$
```

A trap was set to be executed whenever signal 0 was received by the shell. This signal is generated whenever the shell is exited. Because this was set in the login shell, the trap will be taken when you log off. The purpose of this trap is to write the time you logged off into the file `$HOME/logoffs`. The command is enclosed in single quotes to prevent the shell from executing `date` when the trap is defined.

The `trap` command is then executed with no arguments, which results in the display of the changed action to be taken for signal 0 (EXIT). Next, `steve` logs off and then back on again to see whether the trap works. Displaying the contents of `$HOME/logoffs` verifies that the `echo` command was executed when `steve` logged off.

## Ignoring Signals

If the command listed for `trap` is null, the specified signal will be ignored when received. For example, the command

```
trap "" 2
```

specifies that the interrupt signal is to be ignored. You might want to ignore certain signals when performing some operation that you don't want interrupted.

Note that the first argument must be specified for a signal to be ignored and is not equivalent to writing the following, which has a separate meaning of its own:

```
trap 2
```

If you ignore a signal, all subshells also ignore that signal. However, if you specify an action to be taken on receipt of a signal, all subshells will still take the default action on receipt of that signal. For the signals we've described, this means that the subshells will be terminated.

Suppose that you execute the command

```
trap "" 2
```

and then execute a subshell, which in turn executes other shell programs as subshells. If an interrupt signal is then generated, it will have no effect on the shells or subshells that are executing because they will all ignore the signal.

If instead of executing the previous `trap` command you execute

```
trap : 2
```

and then execute your subshells, then on receiving the interrupt signal the current shell will do nothing (it will execute the `null` command), but all active subshells will be terminated (they will take the default action—termination).

## Resetting Traps

After you've changed the default action to be taken on receipt of a signal, you can change it back again with `trap` if you simply omit the first argument; so

```
trap 1 2
```

resets the action to be taken on receipt of signals 1 or 2 back to the default.

## More on I/O

You know about the standard constructs `<`, `>`, and `>>` for input redirection, output redirection, and output redirection with append, respectively. You also know that you can redirect standard error from any command simply by writing

```
command 2> file
```

Sometimes you may want to explicitly write to standard error in your program. You can redirect the standard output for a command to standard error by writing

```
command >& 2
```

The notation `>&` specifies output redirection to a file associated with the *file descriptor* that follows. File descriptor 0 is standard input, descriptor 1 is standard output, and descriptor 2 is standard error. Note that no space is permitted between the `>` and the `&`.

So to write an error message to standard error, you write

```
echo "Invalid number of arguments" >& 2
```

Frequently, you may want to collect the standard output and the standard error output from a program into the same file. If you know the name of the file, this is straightforward enough:

```
command >foo 2>>foo
```

Here, both the standard output and the standard error output from *command* will be written to *foo*.

You can also write

```
command >foo 2>&1
```

to achieve the same effect; standard output is redirected to `foo`, and standard error is redirected to standard output (which has already been redirected to `foo`). Note that because the shell evaluates redirection from left to right on the command line, the last example cannot be written

```
command 2>&1 > foo
```

because this would first redirect standard error to standard output (your terminal by default) and then standard output to `foo`.

You recall that you can also dynamically redirect standard input or output in a program using the `exec` command:

```
exec < datafile
```

redirects standard input from the file `datafile`. Subsequent commands executed that read from standard input will read from `datafile` instead. The command

```
exec > /tmp/output
```

does the same thing with standard output: All commands that subsequently write to standard output will write to `/tmp/output` (unless explicitly redirected elsewhere). Naturally, standard error can be reassigned this way as well:

```
exec 2> /tmp/errors
```

Here, all output to standard error will go to `/tmp/errors`.

## **<&- and >&-**

The characters `>&-` have the effect of closing standard output. If preceded by a file descriptor, the associated file is closed instead. So writing (the impractical)

```
ls >&-
```

causes the output from `ls` to go nowhere because standard output is closed by the shell before `ls` is executed.

The same thing applies for input using `<&-`.

```
$ wc <&-  
  
    0  0  0  
  
$
```

## Inline Input Redirection

If the `<<` characters follow a command in the format

```
command <<word
```

the shell uses the lines that follow as the standard input for *command*, until a line that contains just *word* is found. Here's a small example at the terminal:

```
$ wc -l <<ENDOFDATA           Use lines up to ENDOFDATA as standard input  
  
> here's a line  
  
> and another  
  
> and yet another  
  
> ENDOFDATA  
  
    3  
  
$
```

Here the shell fed every line typed into the standard input of `wc` until it encountered the line



containing just `ENDOFDATA`.

Inline input redirection is a powerful feature when used inside shell programs. It lets you specify the standard input to a command directly in the program, thus obviating the need to write it into a separate file first, or to use `echo` to get it into the standard input of the command.

```
$ cat mailmsg
```

```
mail $* <<END-OF-DATA
```

```
Attention:
```

```
Our monthly computer users group meeting  
will take place on Friday, October 4, 2002 at  
8am in Room 1A-308. Please try to attend.
```

```
END-OF-DATA
```

```
$
```

To execute this program for all members of the group that are contained in the file `users_list`, you could write

```
mailmsg $(cat users_list)
```

The shell performs parameter substitution for the redirected input data, executes back-quoted commands, and recognizes the backslash character. However, any other special characters, such as `*`, `|`, and `"`, are ignored. If you have dollar signs, back quotes, or backslashes in these lines that you don't want interpreted by the shell, you can precede them with a backslash character. Alternatively, if you want the shell to leave the input lines completely untouched, you can precede the word that follows the `<<` with a backslash.

```
$ cat <<FOOBAR
```

```
> $HOME
```

```

> *****

>     \${foobar}

> `date`

> FOOBAR                Terminates the input

/users/steve

*****

     ${foobar}

Wed Oct  2 15:23:15 EDT 2002

$

```

Here the shell supplies all the lines up to **FOOBAR** as the input to `cat`. It substitutes the value for `HOME` but not for `foobar` because it's preceded by a backslash. The `date` command is also executed because back quotes are interpreted.

```

$ cat <<\FOOBAR

> \\\

> `date`

> $HOME

> FOOBAR

\\\

`date`

$HOME

$

```

The backslash before **FOOBAR** tells the shell to leave the following lines alone. So it ignores the dollar signs, backslashes, and back quotes.

Use care when selecting the word that follows the `<<`. Generally, just make sure that it's weird enough so that the chances of it accidentally appearing in the following lines are remote.

If the first character that follows the `<<` is a dash (`-`), leading tab characters in the input will be removed by the shell. This is useful for visually indenting the redirected text.

```
$ cat <<-END
>         Indented lines
>         So there you have it
> END
Indented lines
So there you have it
$
```

## Shell Archives

One of the best uses of the inline input redirection feature is for creating shell *archive* files. With this technique, one or more related shell programs can be put into a single file and then shipped to someone else using the standard Unix `mail` commands. When the archive is received, it can be easily "unpacked" by simply running the shell on it.

For example, here's an archived version of the `lu`, `add`, and `rem` programs used by `rolo`:

```
$ cat rolosubs
#
# Archived programs used by rolo.
#
echo Extracting lu
cat >lu <<\THE-END-OF-DATA
#
# Look someone up in the phone book
#
```

```
if [ "$#" -ne 1 ]
then
    echo "Incorrect number of arguments"
    echo "Usage: lu name"
    exit 1
fi

name=$1
grep "$name" $PHONEBOOK

if [ $? -ne 0 ]
then
    echo "I couldn't find $name in the phone book"
fi

THE-END-OF-DATA

echo Extracting add
cat >add <<\THE-END-OF-DATA
#
# Program to add someone to the phonebook file
#

if [ "$#" -ne 2 ]
then
    echo "Incorrect number of arguments"
```

```
        echo "Usage: add name number"

        exit 1

fi

echo "$1 $2" >> $PHONEBOOK

sort -o $PHONEBOOK $PHONEBOOK

THE-END-OF-DATA

echo Extracting rem

cat >rem <<\THE-END-OF-DATA

#

# Remove someone from the phone book

#

if [ "$#" -ne 1 ]

then

        echo "Incorrect number of arguments"

        echo "Usage: rem name"

        exit 1

fi

name=$1

#

# Find number of matching entries

#
```

```
matches=$(grep "$name" $PHONEBOOK | wc -l)

#

# If more than one match, issue message, else remove it

#

if [ "$matches" -gt 1 ]

then

    echo "More than one match; please qualify further"

elif [ "$matches" -eq 1 ]

then

    grep -v "$name" $PHONEBOOK > /tmp/phonebook

    mv /tmp/phonebook $PHONEBOOK

else

    echo "I couldn't find $name in the phone book"

fi

THE-END-OF-DATA

$
```

To be complete, this archive should probably include `rolo` as well, but we didn't here to conserve space.

Now you have one file, `rolosubs`, that contains the source for the three programs `lu`, `add`, and `rem`, which can be sent to someone else using `mail`:

```
$ mail tony@aisystems.com < rolosubs           Mail the archive
```

```
$ mail tony@aisystems.com                       Mail tony a message
```

Tony,

I mailed you a shell archive containing the programs

lu, add, and rem. rolo itself will be sent along shortly.

Pat

*Ctrl+d*

\$

When `tony` receives the file in his mail, he can extract the three programs simply by running the shell on the file (after having first removed some header lines that `mail` sticks at the beginning of the file):

```
$ sh rolosubs
Extracting lu
Extracting add
Extracting rem
$ ls lu add rem
add
lu
rem
$
```

The `shar` program used to create the `rolosubs` archive file is simple:

```
$ cat shar
#
# Program to create a shell archive
# from a set of files
#
```

```
echo "#"

echo "# To restore, type sh archive"

echo "#"

for file
do

    echo

    echo "echo Extracting $file"

    echo "cat >$file <<\THE-END-OF-DATA"

    cat $file

    echo "THE-END-OF-DATA"

done
```

Refer to the contents of the `rolosubs` file when studying the operation of this `shar` program. Remember, `shar` actually creates a shell program.

More sophisticated archiving programs allow entire directories to be archived and also check to make sure that no data is lost in the transmission (see Exercises 2 and 3 at the end of this chapter). The Unix `sum` command can be used to generate a checksum for a program. This checksum can be generated on the sending end for each file in the archive, and then commands included in the shell archive can verify the sum on the receiving end. If they don't match, an error message can be displayed.



# Functions

The POSIX standard shell supports the concept of functions; note that older shells may not support this feature.

To define a function, you use the general format:

```
name () { command; ... command; }
```

where *name* is the name of the function, the parentheses denote to the shell that a function is being defined, and the commands enclosed between the curly braces define the body of the function. These commands will be executed whenever the function is executed. Note that at least one whitespace character must separate the { from the first command, and that a semicolon must separate the last command from the closing brace if they occur on the same line.

The following defines a function called `nu` that displays the number of logged-in users:

```
nu () { who | wc -l; }
```

You execute a function the same way you execute an ordinary command: simply by typing its name to the shell:

```
$ nu
    22
$
```

Arguments listed after the function on the command line are assigned to the positional parameters `$1`, `$2`, `...`, just as with any other command. Here's a function called `nrrun` that runs `tbl`, `nroff`, and `lp` on the file given as its argument:

```
$ nrrun () { tbl $1 | nroff -mm -Tlp | lp; }
$ nrrun memol           Run it on memol
```

```
request id is laser1-33 (standard input)
```

```
$
```

Functions exist only in the shell in which they're defined; that is, they can't be passed down to subshells. Further, because the function is executed in the current shell, changes made to the current directory or to variables remain after the function has completed execution:

```
$ db () {  
>     PATH=$PATH:/uxn2/data  
>     PS1=DB:  
>     cd /uxn2/data  
>     }  
  
$ db Execute it  
  
DB:
```

As you see, a function definition can continue over as many lines as necessary. The shell displays your secondary command prompt until you close the definition with the `}`.

You can put definitions for commonly used functions inside your `.profile` so that they'll be available whenever you log in. Alternatively, you can group the definitions in a file, say `myfuncs`, and then execute the file in the current shell by typing

```
. myfuncs
```

This has the effect of causing any functions defined inside `myfuncs` to be read in and defined to the current shell.

The following function, called `mycd`, takes advantage of the fact that functions are run in the current environment. It mimics the operation of the Korn shell's `cd` command, which has the capability to substitute portions of the current directory's path with something else (see the discussion of `cd` in [Chapter 15](#), "Interactive and Nonstandard Shell Features," for more details).

```
$ cat myfuncs See what's inside
```

```
#
# new cd function:
#     mycd dir Switches dir
#     mycd old new  Substitute new for old in current directory's path
#
mycd ()
{
    if [ $# -le 1 ]
    then
        # normal case -- 0 or 1 argument
        cd $1
    elif [ $# -eq 2 ]
    then
        # special case -- substitute $2 for $1
        cd $(echo $PWD | sed "s|$1|$2|")
    else
        # cd can't have more than two arguments
        echo mycd: bad argument count
        exit 1
    fi
}

$ . myfuncs           Read in definition

$ pwd
/users/steve

$ mycd /users/pat     Change directory
```

```
$ pwd                                Did it work?
/users/pat
$ mycd pat tony                       Substitute tony for pat
$ pwd
/users/tony
$
```

After a function has been defined, its execution will be faster than an equivalent shell program file. That's because the shell won't have to search the disk for the program, open the file, and read its contents into memory.

Another advantage of functions is the capability to group all your related shell programs in a single file if desired. For example, the `add`, `lu`, and `rem` programs from [Chapter 11](#), "Your Environment," can be defined as functions inside `rolo`. The template for such an approach is shown:

```
$ cat rolo
#
# rolo program written in function form
#
#
#
# Function to add someone to the phonebook file
#
add () {
    # put commands from add program here
}
#
```

```
# Function to look someone up in the phone book
#
lu () {
    # put commands from lu program here
}

#
# Function to remove someone from the phone book
#
rem () {
    # put commands from rem program here
}

#
# rolo - rolodex program to look up, add, and
#     remove people from the phone book
#
# put commands from rolo here
$
```

None of the commands inside the original `add`, `lu`, `rem`, or `rolo` programs would have to be changed. These first three programs are turned into functions by including them inside `rolo`, sandwiched between the function header and the closing curly brace. Note that defining them as functions this way now makes them inaccessible as standalone commands.

## Removing a Function Definition

To remove the definition of a function from the shell, you use the `unset` command with the `-f` option. This is the same command you use to remove the definition of a variable to the shell.

```
$ unset -f nu
```

```
$ nu
```

```
sh: nu: not found
```

```
$
```

## The `return` Command

If you execute an `exit` command from inside a function, its effect is not only to terminate execution of the function but also of the shell program that called the function. If you instead want to just terminate execution of the function, you can use the `return` command, whose format is

```
return n
```

The value `n` is used as the return status of the function. If omitted, the status returned is that of the last command executed. This is also what gets returned if you don't execute a `return` at all in your function. The return status is in all other ways equivalent to the exit status: You can access its value through the shell variable `$?`, and you can also test it in `if`, `while`, and `until` commands.

## The `type` Command

When you type in the name of a command to execute, it's frequently useful to know where that command is coming from. In other words, is the command actually defined as a function? Is it a shell program? Is it a shell built-in? Is it a standard Unix command? This is where the `type` command comes in handy. The `type` command takes one or more command names as its argument and tells you what it knows about it. Here are some examples:

```
$ nu () { who | wc -l; }
```

```
$ type pwd
```

```
pwd is a shell builtin
```

```
$ type troff
```

```
troff is /usr/bin/troff
```

```
$ type cat
```

```
cat is /bin/cat
```

```
$ type nu
```

```
nu is a function
```

```
$
```

## Exercises

- 1: Using `eval`, write a program called `recho` that prints its arguments in reverse order. So

```
recho one two three
```

should produce

```
three two one
```

Assume that more than nine arguments can be passed to the program.

- 2: Modify the `shar` program presented in this chapter to handle directories. `shar` should recognize input files from different directories and should make sure that the directories are created if necessary when the archive is unpacked. Also allow `shar` to be used to archive an entire directory.

```
$ ls rolo
lu
add
rem
rolo
$ shar rolo/lu rolo/add rolo/rem > rolosubs.shar
$ shar rolo > rolo.shar
```

In the first case, `shar` was used to archive three files from the `rolo` directory. In the last case, `shar` was used to archive the entire `rolo` directory.

- 3: Modify `shar` to include in the archive the character count for each file and commands to compare the count of each extracted file against the count of the original file. If a



discrepancy occurs, an error should be noted, as in

```
add: expected 345 characters, extracted 343.
```

Team LiB

◀ PREVIOUS

NEXT ▶

# Chapter 14. Rolo Revisited

## IN THIS CHAPTER

- [Design Considerations](#)
- [rolo](#)
- [add](#)
- [lu](#)
- [display](#)
- [rem](#)
- [change](#)
- [listall](#)
- [Sample Output](#)
- [Exercises](#)

This chapter presents a final version of the `rolo` program. This version is enhanced with additional options and also allows for more general types of entries (other than just names and numbers). The sections in this chapter discuss the individual programs in `rolo`, starting with `rolo` itself. At the end of this chapter, sample output is shown.

## Design Considerations

A more practical type of rolodex program would permit more than just the names and numbers to be stored in the phone book. You'd probably want to keep addresses (maybe even electronic mail addresses) there as well. The new `rolodex` program allows entries in the phone book to consist of multiple lines. For example, a typical entry might be

```
Steve's Ice Cream
```

```
444 6th Avenue
```

```
New York City 10003
```

```
212-555-3021
```

To increase the flexibility of the program, we're allowing an individual entry to contain as many lines as desired. So another entry in the phone book might read

```
YMCA
```

```
(201) 555-2344
```

To logically separate one entry from the next inside the phone book file, each entry is "packed" into a single line. This is done by replacing the terminating newline characters in an entry with a special character. We arbitrarily chose the caret `^`. The only restriction here is that this character not be used as part of the entry itself.

Using this technique, the first entry shown would be stored in the phone book file as

```
Steve's Ice Cream^444 6th Avenue^New York City 10003^212-555-3021^
```

and the second entry shown as

```
YMCA^(201) 555-2344^
```

You'll shortly see how convenient it becomes to process the entries when they're stored in this format. Now we'll describe each program written for the rolodex program.

**Team LiB**

◀ PREVIOUS

NEXT ▶

**rolo**

```
#
# rolo - rolodex program to look up, add,
#       remove and change entries from the phone book
#
#
# Set PHONEBOOK to point to the phone book file
# and export it so other progs know about it
# if it's set on entry, then leave it alone
#
: ${PHONEBOOK:=${HOME}/phonebook}
export PHONEBOOK
if [ ! -e "$PHONEBOOK" ]
then
    echo "$PHONEBOOK does not exist!"
    echo "Should I create it for you (y/n)? \c"
    read answer
    if [ "$answer" != y ]
    then
        exit 1
    fi
fi
```

```
        > $PHONEBOOK || exit 1      # exit if the creation fails
fi

#

# If arguments are supplied, then do a lookup
#

if [ "$#" -ne 0 ]
then
    lu "$@"
    exit
fi

#

# Set trap on interrupt (DELETE key) to continue the loop
#

trap "continue" 2

#

# Loop until user selects 'exit'
#

while true
do
```

```
#
# Display menu
#

echo '
Would you like to:

    1. Look someone up
    2. Add someone to the phone book
    3. Remove someone from the phone book
    4. Change an entry in the phone book
    5. List all names and numbers in the phone book
    6. Exit this program

Please select one of the above (1-6): \c'

#
# Read and process selection
#

read choice
echo
case "$choice"
in
    1) echo "Enter name to look up: \c"
        read name
```

```
    if [ -z "$name" ]
    then
        echo "Lookup ignored"
    else
        lu "$name"
    fi;;
2) add;;
3) echo "Enter name to remove: \c"
    read name
    if [ -z "$name" ]
    then
        echo "Removal ignored"
    else
        rem "$name"
    fi;;
4) echo "Enter name to change: \c"
    read name
    if [ -z "$name" ]
    then
        echo "Change ignored"
    else
        change "$name"
    fi;;
5) listall;;
6) exit 0;;
```



```
        *) echo "Bad choice\a";;

    esac

done
```

Instead of requiring that the user have a phone book file in his or her home directory, the program checks on startup to see whether the variable `PHONEBOOK` has been set. If it has, it's assumed that it contains the name of the phone book file. If it hasn't, it's set to `$HOME/phonebook` as the default. In either case, the program then checks to see whether the file exists, and if it doesn't, instead of immediately exiting, asks the user whether he would like to have an initial file created. This was added so that first-time users of `rolo` can have an empty phone book file created for them by the program.

This version of `rolo` also has a couple of new items added to the menu. Because individual entries can be rather long, an editing option has been added to allow you to edit a particular entry. Formerly, the only way to change an entry was to first remove it and then add a new one, a strategy that was perfectly acceptable when the entries were small.

Another option allows for listing of the entire phone book. With this option, just the first and last lines of each entry are displayed. This assumes that the user follows some convention such as putting the name on the first line and the number on the last.

The entire menu selection process was placed inside a `while` loop so that `rolo` will continue to display menus until the "exit" option is picked from the menu.

A `trap` command is executed before the loop is entered. This `trap` specifies that a `continue` command is to be executed if signal number 2 is received. So if the user presses the Delete key in the middle of an operation (such as listing the entire phone book), the program won't exit but will abort the current operation and simply continue with the loop. This will result in the redisplay of the menu.

Because entries can now span as many lines as desired, the action performed when `add` is selected has been changed. Instead of asking for the name and number, `rolo` executes the `add` program to get the entry from the user.

For the lookup, change, and remove options, a check is made to ensure that the user doesn't simply press the Enter key when asked to type in the name. This avoids the `RE error` that `grep` issues if it's given a null first argument.

Now let's look at the individual programs that `rolo` executes. Each of the original programs has been changed to accommodate the new entry format and also to be more user friendly.

**add**

```
#  
  
# Program to add someone to the phonebook file  
  
#  
  
echo "Type in your new entry"  
echo "When you're done, type just a single Enter on the line."  
  
first=  
entry=  
  
while true  
do  
  
    echo ">> \c"  
  
    read line  
  
    if [ -n "$line" ]  
    then  
  
        entry="$entry$line^"  
  
        if [ -z "$first" ]  
        then  
  
            first=$line  
  
        fi  
    fi  
done
```

```
        else
            break
        fi
done

echo "$entry" >> $PHONEBOOK

sort -o $PHONEBOOK $PHONEBOOK

echo

echo "$first has been added to the phone book"
```

This program adds an entry to the phone book. It continually prompts the user to enter lines until a line with just an Enter is typed (that is, a null line). Each line that is entered is concatenated to the variable `entry`, with the special `^` character used to logically separate one line from the next.

When the `while` loop is exited, the new entry is added to the end of the phone book, and the file is sorted.

```
lu
```

```
#
```

```
# Look someone up in the phone book
```

```
#
```

```
name=$1
```

```
grep "$name" $PHONEBOOK > /tmp/matches$$
```

```
if [ ! -s /tmp/matches$$ ]
```

```
then
```

```
    echo "I can't find $name in the phone book"
```

```
else
```

```
    #
```

```
    # Display each of the matching entries
```

```
    #
```

```
    while read line
```

```
    do
```

```
        display "$line"
```

```
    done < /tmp/matches$$
```

```
fi
```

```
rm /tmp/matches$$
```

This is the program to look up an entry in the phone book. The matching entries are written to the file `/tmp/matches$$`. If the size of this file is zero, no match was found. Otherwise, the program enters a loop to read each line from the file (remember an entry is stored as a single line in the file) and then display it at the terminal. A program called `display` is used for this purpose. This program is also used by the `rem` and `change` programs to display entries at the terminal.

Team LiB

◀ PREVIOUS

NEXT ▶

**display**

```
#
# Display entry from the phonebook
#

echo

echo "-----"

entry=$1

IFS="^"

set $entry

for line in "$1" "$2" "$3" "$4" "$5" "$6"
do
    printf "| %-34.34s |\n" $line
done

echo "|          o          o          |"

echo "-----"

echo
```

As noted, this program displays an entry passed as its argument. To make the output more aesthetically pleasing, the program actually "draws" a rolodex card. So typical output from `display` would look like this:

```
-----
```

```
| Steve's Ice Cream |
| 444 6th Avenue |
| New York City 10003 |
| 212-555-3021 |
| |
| |
| o o |
```

---

After skipping a line and then displaying the top of the card, `display` changes `IFS` to `^` and then executes the `set` command to assign each "line" to a different positional parameter. For example, if `entry` is equal to

```
Steve's Ice Cream^444 6th Avenue^New York City 10003^212-555-3021^
```

executing the `set` command assigns `Steve's Ice Cream` to `$1`, `444 6th Avenue` to `$2`, `New York City 10003` to `$3`, and `212-555-3021` to `$4`.

After executing the `set`, the program enters a `for` loop that will be executed exactly six times, no matter how many lines are contained in the entry (this ensures uniformity of our rolodex cards—the program can be easily modified to "draw" larger-sized cards if needed). If the `set` command was executed on `Steve's Ice Cream` as shown previously, `$5` and `$6` would be null, thus resulting in two blank lines to "fill out" the bottom of the card.

The `printf` command displays a line exactly 38 characters wide: the leading `|` followed by a space followed by the first 34 characters of `$line` followed by a space and a `|`.

```
rem
```

```
#
```

```
# Remove someone from the phone book
```

```
#
```

```
name=$1
```

```
#
```

```
# Get matching entries and save in temp file
```

```
#
```

```
grep "$name" $PHONEBOOK > /tmp/matches$$
```

```
if [ ! -s /tmp/matches$$ ]
```

```
then
```

```
    echo "I can't find $name in the phone book"
```

```
    exit 1
```

```
fi
```

```
#
```

```
# Display matching entries one at a time and confirm removal
```

```
#
```

```
while read line
```



```

do

    display "$line"

    echo "Remove this entry (y/n)? \c"

    read answer < /dev/tty

    if [ "$answer" = y ]

    then

        break

    fi

done < /tmp/matches$$

rm /tmp/matches$$

if [ "$answer" = y ]

then

    if grep -v "^$line$" $PHONEBOOK > /tmp/phonebook$$

    then

        mv /tmp/phonebook$$ $PHONEBOOK

        echo "Selected entry has been removed"

    else

        echo "Entry not removed"

    fi

fi

```

The `rem` program collects all matching entries into a temporary file. If the size of the file is zero, no match was found and an appropriate message is issued. Otherwise, for each matching entry, the program displays the entry and asks the user whether that entry is to be removed. This provides

reassurance to the user that the entry the user intends to remove is the same one that the program intends to remove, even in the single match case.

After a `y` has been typed to the program, a `break` command is executed to exit from the loop. Outside the loop, the program tests the value of `answer` to determine how the loop was exited. If its value is not equal to `y`, then the user doesn't want to remove an entry after all (for whatever reason). Otherwise, the program proceeds with the removal by `grep`ing out all lines but the desired one (and here the pattern specified to `grep` is made to match only entire lines by anchoring it to the start and end of the line).

Team LiB

◀ PREVIOUS

NEXT ▶

**change**

```
#  
# Change an entry in the phone book  
#  
  
name=$1  
  
#  
# Get matching entries and save in temp file  
#  
  
grep "$name" $PHONEBOOK > /tmp/matches$$  
if [ ! -s /tmp/matches$$ ]  
then  
    echo "I can't find $name in the phone book"  
    exit 1  
fi  
  
#  
# Display matching entries one at a time and confirm change  
#  
  
while read line  
do
```

```
display "$line"

echo "Change this entry (y/n)? \c"

read answer < /dev/tty

if [ "$answer" = y ]
then
    break
fi
done < /tmp/matches$$

rm /tmp/matches$$

if [ "$answer" != y ]
then
    exit
fi

#
# Start up editor on the confirmed entry
#

echo "$line\c" | tr '^' '\012' > /tmp/ed$$

echo "Enter changes with ${EDITOR:=/bin/ed}"

trap "" 2          # don't abort if DELETE hit while editing

$EDITOR /tmp/ed$$
```

```

#
# Remove old entry now and insert new one
#

grep -v "^$line$" $PHONEBOOK > /tmp/phonebook$$
{ tr '\012' '^' < /tmp/ed$$; echo; } >> /tmp/phonebook$$
# last echo was to put back trailing newline translated by tr

sort /tmp/phonebook$$ -o $PHONEBOOK

rm /tmp/ed$$ /tmp/phonebook$$

```

The `change` program allows the user to edit an entry in the phone book. The initial code is virtually identical to `rem`: it finds the matching entries and then prompts the user to select the one to be changed.

The selected entry is then written into the temporary file `/tmp/ed$$`, with the `^` characters translated to newlines. This "unfolds" the entry into separate lines for convenient editing. The program then displays the message

```
echo "Enter changes with ${EDITOR:=/bin/ed}"
```

which serves a dual purpose: It tells the user what editor will be used to make the change while at the same time setting the variable `EDITOR` to `/bin/ed` if it's not already set. This technique allows the user to use his or her preferred editor by simply assigning its name to the variable `EDITOR` and exporting it before executing `rolo`:

```
$ EDITOR=vi; export EDITOR; rolo
```

The signal generated by the Delete key (2) is ignored so that if the user presses this key while in the editor, the `change` program won't abort. The editor is then started to allow the user to edit the entry. After the user makes his changes, writes the file, and quits the editor, control is given back to

`change`. The old entry is then removed from the phone book with `grep`, and the modified entry is converted into the special internal format with `tr` and tacked onto the end. An extra newline character must be added here to make sure that a real newline is stored in the file after the entry. This is done with an `echo` with no arguments.

The phone book file is then sorted, and the temporary files removed.

[Team LiB](#)

[← PREVIOUS](#)

[NEXT →](#)

**listall**

```
#
# list all of the entries in the phone book
#

IFS='^'      # to be used in set command below

echo "-----"

while read line
do
    #
    # Get the first and last fields, presumably names and numbers
    #

    set $line

    #
    # display 1st and last fields (in reverse order!)
    #

    eval printf "\%-40.40s %s\n\" \"\$1\" \"\${$#}\""
done < $PHONEBOOK

echo "-----"
```

The `listall` program lists all entries in the phone book, printing just the first and last lines of each

entry. The internal field separator characters (`IFS`) is set to a `^`, to be used later inside the loop. Each line from the phone book file is then read and assigned to the variable `line`. The `set` command is used to assign each field to the positional parameters.

The trick now is to get the value of the first and last positional parameters because that's what we want to display. The first one is easy because it can be directly referenced as `$1`. To get the last one, you use `eval` as you saw in [Chapter 13](#), "Loose Ends." The command

```
eval echo \${$#}
```

has the effect of displaying the value of the last positional parameter. The command

```
eval printf "\%-40.40s %-s\n\" \"$1\" \"\${$#}\"
```

gets evaluated to

```
printf "\%-40.40s %-s\n" "Steve's Ice Cream" "${4}"
```

using the entry shown previously as the example, and then the shell rescans the line to substitute the value of `${4}` before executing `printf`.



## Sample Output

Now it's time to see how `rolo` works. We'll start with an empty phone book and add a few entries to it. Then we'll list all the entries, look up a particular one, and change one (using the default editor `ed`—remember that the variable `EDITOR` can always be set to a different editor and then exported). To conserve space, we'll show only the full menu that `rolo` displays the first time.

```
$ PHONEBOOK=/users/steve/misc/book
```

```
$ export PHONEBOOK
```

```
$ rolo                Start it up
```

```
/users/steve/misc/book does not exist!
```

```
Should I create it for you (y/n)? y
```

```
Would you like to:
```

1. Look someone up
2. Add someone to the phone book
3. Remove someone from the phone book
4. Change an entry in the phone book
5. List all names and numbers in the phone book
6. Exit this program

```
Please select one of the above (1-6): 2
```

```
Type in your new entry
```

```
When you're done, type just a single Enter on the line.
```

```
>> Steve's Ice Cream
```

>> **444 6th Avenue**  
>> **New York City 10003**  
>> **212-555-3021**  
>>

Steve's Ice Cream has been added to the phone book

Would you like to:

...

Please select one of the above (1-6): **2**

Type in your new entry

When you're done, type just a single Enter on the line.

>> **YMCA**  
>> **973-555-2344**  
>>

YMCA has been added to the phone book

Would you like to:

...

Please select one of the above (1-6): **2**

Type in your new entry

When you're done, type just a single Enter on the line.

>> **Maureen Connelly**  
>> **Hayden Book Companu**

>> 10 Mulholland Drive  
>> Hasbrouck Heights, N.J. 07604  
>> 201-555-6000  
>>

Maureen Connelly has been added to the phone book

Would you like to:

...

Please select one of the above (1-6): 2

Type in your new entry

When you're done, type just a single Enter on the line.

>> Teri Zak  
>> Hayden Book Company  
>> (see Maureen Connelly for address)  
>> 201-555-6060  
>>

Teri Zak has been added to the phone book

Would you like to:

...

Please select one of the above (1-6): 5



```
| (see Maureen Connelly for address)|
| 201-555-6060                      |
|                                     |
|      o                             o  |
```

-----

Would you like to:

...

Please select one of the above (1-6): 4

Enter name to change: **Maureen**

-----

```
| Maureen Connelly                    |
| Hayden Book Companu                 |
| 10 Mulholland Drive                 |
| Hasbrouck Heights, NJ 07604        |
| 201-555-6000                       |
|      o                             o  |
```

-----

Change this person (y/n)? **y**

Enter changes with /bin/ed

101

**1,\$p**

Maureen Connelly

```
Hayden Book Companu
10 Mulholland Drive
Hasbrouck Heights, NJ 07604
201-555-6000
```

```
2s/anu/any           Change the misspelling
```

```
Hayden Book Company
```

```
w
```

```
101
```

```
q
```

```
Would you like to:
```

```
...
```

```
Please select one of the above (1-6): 6
```

```
$
```

The only function not tested here is removal of an entry.

Hopefully this example has given you some insight on how to develop larger shell programs, and how to use the many different programming tools provided by the system. Other than the shell built-ins, `rolo` relies on `tr`, `grep`, an editor, `sort`, and the standard file system commands such as `mv` and `rm` to get the job done. The simplicity and elegance that enable you to easily tie all these tools together account for the deserved popularity of the Unix system.

See [Appendix B](#) for more information on downloading the `rolo` programs.

[Chapter 15](#), "Interactive and Nonstandard Shell Features," introduces you to interactive features of the shell and two shells that have some nice features not found in the POSIX standard shell.

## Exercises

- 1: Modify `rolo` so that upper- and lowercase letters are not distinguished when doing a lookup in the phone book.
- 2: Add a `-m` command-line option to `rolo` to send mail to the person who follows on the command line. Have `rolo` look up the person in the phone book and then look for the string `mail:mailaddr` in the matching entry, where `mailaddr` is the person's mail address. Then start up an editor (as in change mode) to allow the user to enter the mail message. When the editing is complete, mail the message to the user. If no mail address is found in the phone book, prompt for it.

Also add a mail option to the menu so that it can be selected interactively. Prompt for the name of the person to send mail to.

- 3: After adding the `-m` option, add a `-f` option to specify that the mail message is to be taken from the file that follows on the command line. So

```
rolo -m tony -f memo
```

should look up `tony` and mail him the contents of the file `memo`.

- 4: Can you think of other ways to use `rolo`? For example, can it be used as a small general-purpose database program (for example, for storing recipes or employee data)?
- 5: Modify `rolo` to use the following convention instead of the exported `PHONEBOOK` variable: the file `.rolo` in each `rolo` user's home directory contains the pathname to that user's phone book file, for example:

```
$ cat $HOME/.rolo  
  
/users/steve/misc/phonebook  
  
$
```

Then add an option to `rolo` to allow you to look up someone in another user's phone book (provided that you have read access to it). This option should be added to the command line (as a `-u` option) as well as to the menu. For example,

```
$ rolo -u pat Pizza
```

would look up `Pizza` in `pat`'s phone book, no matter who is running `rolo`. The program can find `pat`'s phone book by looking at `.rolo` in `pat`'s home directory.

- 6: What happens with `rolo` if the user adds an entry containing a `^` or `[` character?
- 7: Add a `-s` (send) option to `rolo` to mail a rolodex entry to a specified user. So

```
$ rolo -s tom pizza
```

should send the rolodex card entry for `pizza` to the user `tom`.



# Chapter 15. Interactive and Nonstandard Shell Features

## IN THIS CHAPTER

- [Getting the Right Shell](#)
- [The `ENV` File](#)
- [Command-Line Editing](#)
- [Command History](#)
- [The `vi` Line Edit Mode](#)
- [The `emacs` Line Edit Mode](#)
- [Other Ways to Access Your History](#)
- [Functions](#)
- [Integer Arithmetic](#)
- [The `alias` Command](#)
- [Arrays](#)
- [Job Control](#)
- [The Restricted Shell `rsh`](#)
- [Miscellaneous Features](#)
- [Compatibility Summary](#)
- [Exercises](#)

In this chapter you'll learn about shell features that are either useful to interactive users or not part of the POSIX shell standard. These features are available in Bash and the Korn shell, the two most commonly available POSIX-compliant shells.

The Korn shell was developed by David Korn of AT&T Bell Laboratories. It was designed to be "upward compatible" with the System V Bourne shell and the POSIX standard shell. It is available in the standard Unix distributions from Sun, HP, and IBM, and is the default shell on MIPS workstations.

Bash (short for Bourne-Again Shell) was developed by Brian Fox for the Free Software Foundation. It was also designed to be upward compatible with the System V Bourne shell and the POSIX standard

shell, and also contains many extensions from the Korn and C shells. Bash is the standard shell on Linux systems.

Except for a few minor differences, Bash and the Korn shell provide all the POSIX standard shell's features, as well as many new ones. To give you an idea of the compatibility of these shells with the POSIX standard, all shell programs in the previous chapters work under both Bash and the Korn shell.

We'll note any nonstandard features that we discuss in this chapter, and [Table 15.4](#) at the end of this chapter lists the features supported by the different shells.

**Team LiB**

◀ PREVIOUS

NEXT ▶

## Getting the Right Shell

Most shells follow a convention that allows you to select a specific program to run a file. If the first two characters on the first line of a file are `#!`, the remainder of the line specifies an interpreter for the file. So

```
#!/usr/bin/ksh
```

specifies the Korn shell and

```
#!/usr/bin/bash
```

specifies Bash. If you use constructs specific to one shell, you can use this feature to force that shell to run your programs, avoiding compatibility problems.

Note that you can put any program you want here, so a Perl program beginning with

```
#!/usr/bin/perl
```

forces the shell to execute `/usr/bin/perl` on it.

You have to use this feature with caution, however, because many programs, such as Perl, don't reside in a standard place on every Unix system. Also, this is not a feature specified by the POSIX standard, even though it's found in every modern shell we've seen and is even implemented at the operating system level on many Unix versions.

## The `ENV` File

When you start the shell, one of the first things it does is look in your environment for a variable called `ENV`. If it finds it, the file specified by `ENV` will be executed, much like the `profile` is executed when logging in. The `ENV` file usually contains commands to set up the shell's environment. Throughout this chapter, we'll mention various things that you may want to put into this file.

If you do decide to have an `ENV` file, you should set and export the `ENV` variable inside your `.profile` file:

```
$ cat .profile
...
ENV=$HOME/.alias
export ENV
...
$
```

For Bash users, the `ENV` file is read only when Bash is invoked with the name `sh` or with the `--posix` command-line option, or after `set -o posix` is executed (all of which force POSIX standard compliance). By default, when a noninteractive Bash shell is started (for example, when you run a shell program), it reads commands from the file specified by the `BASH_ENV` environment variable, and when an interactive Bash shell is started (for example, by typing `bash` at the command prompt), it doesn't.

You should also set and export inside your `.profile` file a variable called `SHELL`.

```
$ cat .profile
...
SHELL=/usr/bin/ksh
export SHELL
...
$
```

This variable is used by certain applications (such as `vi`) to determine what shell to start up when you execute a shell escape. In such cases, you want to make sure that each time you start up a new shell, you get the shell you want and not an older Bourne shell.

**Team LiB**

[← PREVIOUS](#)

[NEXT →](#)

## Command-Line Editing

Line edit mode is a feature of the shell that allows you to edit a command line using built-in commands that mimic those found in two popular screen editors. The POSIX standard shell provides the capability to mimic `vi`; however, both Bash and the Korn shell also support an `emacs` line edit mode. We list the complete set of `vi` commands in [Table A.4](#) in [Appendix A](#), "Shell Summary."

If you've used either of these screen editors, you'll find that the built-in line editors in the shell are faithful reproductions of their full-screen counterparts. If you've never used a screen editor, don't be intimidated. This capability is one of the most useful features in the shell. In fact, after learning how to use one of the shell's built-in editors, you'll be able to learn `vi` or `emacs` with little effort.

To turn on a line edit mode, you use the `set` command with the `-o mode` option, where *mode* is either `vi` or `emacs`:

```
$ set -o vi           Turn on vi mode
```

Note that you can put this in your `.profile` or `ENV` file to automatically start up the shell with one of the edit modes turned on.

## Command History

As we said before, the shell keeps a history of previously entered commands. Each time you press the Enter key to execute a command, that command gets added to the end of this history list. This command list is actually stored inside a file, which means that you can access previously entered commands across login sessions. By default, the history list is kept in a file in your home directory under the name `.sh_history` (`.bash_history` for Bash, unless it is started with the `--posix` option). You can change this filename to anything you want by setting the variable `HISTFILE` to the name of your history file. This variable can be set and exported in your `.profile` file.

Naturally, there is a limit to the number of commands the shell records. The default value of this limit varies by implementation, but the POSIX standard requires it to be at least 128; the default value for the Korn shell is 128; the default value for Bash is 500. Each time you log in, the shell automatically truncates your history file to this length.

You can control the size of your history file through the `HISTFILE` variable. You may find that the default size isn't adequate for your needs, in which case you may want to set the `HISTFILE` variable to a larger value, such as 500 or 1000. The value you assign to `HISTSIZE` can be set and exported in your `.profile` file:

```
$ cat .profile
...
HISTSIZE=500
export HISTSIZE
...
$
```

Be reasonable about the values that you assign to `HISTSIZE`. The larger the value, the more disk space you will need to store the history file, and the longer it will take the shell to search through the entire history file.

## The `vi` Line Edit Mode

After turning on the `vi` line editor, you will be placed in *input* mode. You probably won't even notice anything different about input mode because you can type in and execute commands almost the same as before you started the `vi` line editor:

```
$ set -o vi
```

```
$ echo hello
```

```
hello
```

```
$ pwd
```

```
/users/pat
```

```
$
```

To make use of the line editor, you must enter *command* mode by pressing the ESCAPE or Esc key, usually in the upper-left corner of the keyboard. When you enter command mode, the cursor moves to the left one space, to the last character typed in. The *current character* is whatever character the cursor is on; we'll say more about the current character in a moment. When in command mode, you can enter `vi` commands. *Note that `vi` commands are not followed by an Enter.*

One problem often encountered when typing in long commands is that you may notice an error in a command line after you finish typing it in. Invariably, the error is at the beginning of the line. In command mode, you can move the cursor around without disturbing the command line. After you've moved the cursor to the place where the error is, you can change the letter or letters to whatever you want.

In the following examples, the underline (  ) represents the cursor. A command line will be shown, followed by one or more keystrokes, followed by what the line looks like after applying the keystrokes:

*before keystrokes after*

First, let's look at moving the cursor around. The H key moves the cursor to the left and the L key moves it to the right. Try this out by entering command mode and pressing the H and L keys a few times. The cursor should move around on the line. If you try to move the cursor past the left or right side of the line, the shell "beeps" at you.

```
$ mary had a little larb      Esc      $ mary had a little larb
```



\$ mary had a little larb	h	\$ mary had a little larb
\$ mary had a little larb	h	\$ mary had a little larb
\$ mary had a little larb	l	\$ mary had a little larb

After the cursor is on the character you want to change, you can use the `x` command to delete the current character ("X" it out).

\$ mary had a little larb	x	\$ mary had a little lab
---------------------------	---	--------------------------

Note that the `b` moved to the left when the `r` was deleted and is now the current character.

To add characters to the command line, you can use the `i` and `a` commands. The `i` command inserts characters *before* the current character, and the `a` command adds characters *after* the current character. Both of these commands put you back into input mode; you must press `Esc` again to go back to command mode.

\$ mary had a little lab	im	\$ mary had a little lamb
\$ mary had a little lamb	m	\$ mary had a little lammb
\$ mary had a little lammb	Esc	\$ mary had a little lammb
\$ mary had a little lammb	x	\$ mary had a little lamb
\$ mary had a little lamb	a	\$ mary had a little lamb_
\$ mary had a little lamb_	da	\$ mary had a little lambda_

If you think that moving the cursor around by repeatedly pressing `h` and `l` is slow, you're right. The `h` and `l` commands may be preceded by a number that specifies the number of spaces to move the cursor.

\$ mary had a little lambda_	Esc	\$ mary had a little lambda
\$ mary had a little lambda	10h	\$ mary had a little lambda
\$ mary had a little lambda	13h	\$ mary had a little lambda
\$ mary had a little lambda	5x	\$ had a little lambda

As you can see, the `x` command can also be preceded by a number to tell it how many characters to delete.

You can easily move to the end of the line by typing the `$` command:

```
$ had a little lambda      $      $ had a little lambda
```

To move to the beginning of the line, you use the `0` (that's a zero) command:

```
$ had a little lambda      0      $ had a little lambda
```

Two other commands useful in moving the cursor are the `w` and `b` commands. The `w` command moves the cursor forward to the beginning of the next word, where a word is a string of letters, numbers, and underscores delimited by blanks or punctuation. The `b` command moves the cursor backward to the beginning of the previous word. These commands may also be preceded by a number to specify the number of words to move forward or backward.

```
$ had a little lambda      w      $ had a little lambda
```

```
$ had a little lambda      2w     $ had a little lambda
```

```
$ had a little lambda      3b     $ had a little lambda
```

At any time you can press Enter and the current line will be executed as a command.

```
$ had a little lambda      Hit Enter
```

```
ksh: had: not found
```

```
$ _
```

After a command is executed, you are placed back in input mode.

## Accessing Commands from Your History

So far, you've learned how to edit the current line. You can use the `vi` commands `k` and `j` to retrieve commands from your history. The `k` command replaces the current line on your terminal with the previously entered command, putting the cursor at the beginning of the line. Let's assume that these commands have just been entered:

```
$ pwd
/users/pat
$ cd /tmp
$ echo this is a test
this is a test
$ _
```

Now go into command mode and use `k` to access them:

```
$ _          Esc k          $ echo this is a test
```

Every time `k` is used, the current line is replaced by the previous line from the command history.

```
$ echo this is a test      k          $ cd /tmp
$ cd /tmp                  k          $ pwd
```

To execute the command being displayed, just press the Enter key.

```
$ pwd          Hit Enter
/tmp
$ _
```

The `j` command is the reverse of the `k` command and is used to display the next command in the history.

The `/` command is used to search through the command history for a command containing a string. If the `/` is entered, followed by a string, the shell searches backward through its history to find the most recently executed command that contains that string anywhere on the command line. The command will then be displayed. If no line in the history contains the string, the shell "beeps" the terminal. When the `/` is entered, the current line is replaced by a `/`.

```
/tmp  
$ _          Esc /test  /test_
```

The search is begun when the Enter key is pressed.

```
/test_      Enter      $ echo this is a test
```

To execute the command that results from the search, Enter must be pressed again.

```
$ echo this is a test      Hit Enter again  
this is a test  
$ _
```

If the command that's displayed isn't the one you're interested in, you can continue the search through the command history by simply typing `/` and pressing Enter. The shell uses the string that you entered the last time you executed the search command.

When you've found the command in the history (either by `k`, `j`, or `/`), you can edit the command using the other `vi` commands we've already discussed. Note that you don't actually change the command in the history: That command cannot be changed after it is entered. Instead, you are editing a copy of the command in the history, which will itself be entered in the history when you press Enter.

[Table 15.1](#) summarizes the basic `vi` line edit commands.

## Table 15.1. Basic `vi` Line Edit Commands

## Command Meaning

<code>h</code>	Move left one character.
<code>l</code>	Move right one character.
<code>b</code>	Move left one word.
<code>w</code>	Move right one word.
<code>0</code>	Move to start of line.
<code>\$</code>	Move to end of line.
<code>x</code>	Delete character at cursor.
<code>dw</code>	Delete word at cursor.
<code>rC</code>	Change character at cursor to <i>C</i> .
<code>a</code>	Enter input mode and enter text after the current character.
<code>i</code>	Enter input mode and insert text before the current character.
<code>k</code>	Get previous command from history.
<code>j</code>	Get next command from history.
<code>/string</code>	Search history for the most recent command containing <i>string</i> , if <i>string</i> is null, the previous string will be used.

## The Line Edit Mode

After turning on the `emacs` line editor, you probably won't even notice anything different because you can type in and execute commands the same way as before:

```
$ set -o emacs
```

```
$ echo hello
```

```
hello
```

```
$ pwd
```

```
/users/pat
```

```
$
```

To use the line editor, you enter *emacs commands*. `emacs` commands are either *control* characters—that is, characters typed in by holding down the Ctrl key and pressing another character—or they are characters preceded by the ESCAPE or Esc key. You may enter `emacs` commands anytime you want; there are no separate modes like the `vi` line editor. *Note that `emacs` commands are not followed by an Enter.* We cover only a few of them here; for a complete list of commands, refer to the documentation for Bash or the Korn shell.

First, let's look at moving the cursor around. The `Ctrl+b` command moves the cursor to the left, and the `Ctrl+f` command moves it to the right. Try this out by pressing `Ctrl+b` and `Ctrl+f` a few times. The cursor should move around on the line. If you try to move the cursor past the left or right side of the line, the shell simply ignores you.

```
$ mary had a little larb_      Ctrl+b      $ mary had a little larb
```

```
$ mary had a little larb      Ctrl+b      $ mary had a little larb
```

```
$ mary had a little larb      Ctrl+b      $ mary had a little larb
```

```
$ mary had a little larb      Ctrl+f      $ mary had a little larb
```

After the cursor is on the character you want to change, you can use the `Ctrl+d` command to delete the current character.

```
$ mary had a little larb      Ctrl+d      $ mary had a little lab
```

Note that the `b` moved to the left when the `r` was deleted and is now the current character.

To add characters to the command line, you simply type them in. The characters are inserted *before* the current character.

```
$ mary had a little lab      m      $ mary had a little lamb
$ mary had a little lamb     m      $ mary had a little lammb
$ mary had a little lammb    Ctrl+h  $ mary had a little lamb
```

Note that the current erase character (usually either `#` or `Ctrl+h`) will *always* delete the character to the left of the cursor.

The `Ctrl+a` and `Ctrl+e` commands may be used to move the cursor to the beginning and end of the command line, respectively.

```
$ mary had a little lamb     Ctrl+a    $ mary had a little lamb
$ mary had a little lamb     Ctrl+e    $ mary had a little lamb_
```

Note that the `Ctrl+e` command places the cursor one space to the right of the last character on the line. (When you're not in `emacs` mode, the cursor is always at the end of the line, one space to the right of the last character typed in.) When you're at the end of the line, anything you type will be appended to the line.

```
$ mary had a little lamb_    da      $ mary had a little lambda_
```

Two other commands useful in moving the cursor are the `Esc f` and `Esc b` commands. The `Esc f` command moves the cursor forward to the end of the current word, where a word is a string of letters, numbers, and underscores delimited by blanks or punctuation. The `Esc b` command moves the cursor backward to the beginning of the previous word.

```
$ mary had a little lambda_  Esc b    $ mary had a little lambda
```

```
$ mary had a little lambda      Esc b      $ mary had a little lambda
$ mary had a little lambda      Esc b      $ mary had a little lambda
$ mary had a little lambda      Esc f      $ mary had a_little lambda
$ mary had a_little lambda      Esc f      $ mary had a little_lambda
```

At any time you can press the Enter key and the current line will be executed as a command.

```
$ mary had a little_lambda      Hit Enter; enter command
ksh: mary: not found
$ _
```

## Accessing Commands from Your History

So far, you've learned how to edit the current line. As we said before, the shell keeps a history of recently entered commands. To access these commands, you can use the `emacs` commands `Ctrl+p` and `Ctrl+n`. The `Ctrl+p` command replaces the current line on your terminal with the previously entered command, putting the cursor at the end of the line. Let's assume that these commands have just been entered:

```
$ pwd
/users/pat
$ cd /tmp
$ echo this is a test
this is a test
$ _
```

Now use `Ctrl+p` to access them:

```
$ _      Ctrl+p      $ echo this is a test_
```



Every time *Ctrl+p* is used, the current line is replaced by the previous line from the command history.

```
$ echo this is a test_      Ctrl+p      $ cd /tmp_  
$ cd /tmp_                 Ctrl+p      $ pwd_
```

To execute the command being displayed, just press Enter.

```
$ pwd_                      Hit Enter  
/tmp  
$ _
```

The *Ctrl+n* command is the reverse of the *Ctrl+p* command and is used to display the next command in the history.

The *Ctrl+r* command is used to search through the command history for a command containing a string. The *Ctrl+r* is entered followed by the string to search for, followed by the Enter key. The shell then searches the command history for the most recently executed command that contains that string on the command line. If found, the command line is displayed; otherwise, the shell "beeps" the terminal. When the *Ctrl+r* is typed, the shell replaces the current line with *^R*:

```
$ _                          Ctrl+r test    $ ^Rtest_
```

The search is initiated when Enter is pressed.

```
$ ^Rtest_                    Enter          $ echo this is a test_
```

To execute the command that is displayed as a result of the search, Enter must be pressed again.

```
$ echo this is a test_      Hit Enter again
```

```
this is a test
```

```
$ _
```

To continue the search through the command history, you simply type *Ctrl+r* followed by an Enter.

Bash handles *Ctrl+ra* a little differently. When you type *Ctrl+r*, Bash replaces the current line with `(reverse-i-search)`'`:

```
$ _                               Ctrl+r          (reverse-i-search)`': _
```

As you type text, the line is updated inside the ``'` with the text you type, and the rest of the line is updated with the matching command:

```
(reverse-i-search)`': _ c (reverse-i-search)`c': echo this is a test
```

```
(reverse-i-search)`c': echo this is a test  d   (reverse-i-search)`cd': cd /tmp
```

Note how Bash highlights the matching part of the command by placing the cursor on it. As with the Korn shell, the command is executed by pressing Enter.

When you've found the command in the history (either by *Ctrl+p*, *Ctrl+n*, or *Ctrl+^*), you can edit the command using the other `emacs` commands we've already discussed. Note that you don't actually change the command in the history: That command cannot be changed after it is entered. Instead, you are editing a copy of the command in the history, which will itself be entered in the history when you press Enter.

[Table 15.2](#) summarizes the basic line edit commands.

Table 15.2. Basic `emacs` Line Edit Commands

Command	Meaning
<i>Ctrl+b</i>	Move left one character
<i>Ctrl+f</i>	Move right one character
<i>Esc+f</i>	Move forward one word

Command	Meaning
<i>Esc+b</i>	Move back one word
<i>Ctrl+a</i>	Move to start of line
<i>Ctrl+e</i>	Move to end of line
<i>Ctrl+d</i>	Delete current character
<i>Esc+d</i>	Delete current word
<i>erase char</i>	(User-defined erase character, usually # or <i>Ctrl+h</i> ), delete previous character
<i>Ctrl+p</i>	Get previous command from history
<i>Ctrl+n</i>	Get next command from history
<i>Ctrl+r string</i>	Search history for the most recent command line containing <i>string</i>

## Other Ways to Access Your History

There are several other ways to access your command history that are worth noting.

### The `history` Command

The operation of the `history` command differs between the Korn shell and Bash because it is not part of the POSIX standard.

The Korn shell `history` command writes your last 16 commands to standard output:

```
$ history
507  cd shell
508  cd ch15
509  vi int
510  ps
511  echo $HISTSIZE
512  cat $ENV
513  cp int int.sv
514  history
515  exit
516  cd shell
517  cd ch16
518  vi all
519  run -n5 all
520  ps
521  lpr all.out
522  history
```

The numbers to the left are simply relative command numbers (command number 1 would be the first, or oldest, command in your history).

Without any arguments, the Bash `history` command lists your entire history (as specified by the `HISTSIZE` variable) to standard output. If you just want to see the last few commands, you must specify the number of commands to display as an argument:

```
$ history 10

513  cp int int.sv

514  history

515  exit

516  cd shell

517  cd ch16

518  vi all

519  run -n5 all

520  ps

521  lpr all.out

522  history 10

$
```

## The `fc` Command

The `fc` command allows you to start up an editor on one or more commands from your history or to simply write a list of history commands to your terminal. In the latter form, which is indicated by giving the `-l` option to `fc`, it is like typing in `history`, only more flexible (you can specify a range of commands to be listed or can get fewer or more than the last 16 commands listed). For example, the command

```
fc -l 510 515
```

writes commands 510 through 515 to standard output, whereas the command

```
fc -n -l -20
```

writes the last 20 commands to standard output, not preceded by line numbers (`-n`). Suppose that you've just executed a long command line and then decide that it would be nice to turn that command line into a shell program called `runx`. You can use `fc` to get the command from your history and I/O redirection to write that command to a file:

```
fc -n -l -1 > runx
```

(That's the letter `l` followed by the number `-1`.) `fc` is described in full detail in [Appendix A](#).

## The `r` Command

A simple Korn shell command allows you to re-execute previous commands using even a fewer number of keystrokes than described. If you simply type in the `r` command, the Korn shell re-executes your last command:

```
$ date
```

```
Thu Oct 24 14:24:48 EST 2002
```

```
$ r
```

*Re-execute previous command*

```
date
```

```
Thu Oct 24 14:25:13 EST 2002
```

```
$
```

When you type in the `r` command, the Korn shell redisplay the previous command and then immediately executes it.

If you give the `r` command the name of a command as an argument, the Korn shell re-executes the most recent command line from your history that *begins* with the specified argument:

```
$ cat docs/planA
```

...

```
$ pwd
```

```
/users/steve
```

```
$ r cat Rerun last cat command
```

```
cat docs/planA
```

```
$
```

Once again, the Korn shell redisplay the command line from its history before automatically re-executing it.

The final form of the `r` command allows you to substitute the first occurrence of one string with the next. To re-execute the last `cat` command on the file `planB` instead of `planA`, you could type:

```
$ r cat planA=planB
```

```
cat docs/planB
```

...

```
$
```

or even more simply, you could have typed:

```
$ r cat A=B
```

```
cat docs/planB
```

...

```
$
```

Bash has the `!` built-in command; `!!` re-executes the previous command, and `!string` re-executes the most recent command line from your history that begins with *string*.

```
$ !!
```

```
cat docs/planB
...
$ !d
date
Thu Oct 24 14:39:40 EST 2002
$
```

Note that no spaces can exist between `!` and *string*.

The `fc` command can be used with the `-s` option to do the same thing with any POSIX-compliant shell (the `r` command is actually an *alias* to the `fc` command in the Korn shell—more on that later in this chapter):

```
$ fc -s cat
cat docs/planB
...
$ fc -s B=C
cat docs/planC
...
$
```



# Functions

Bash and the Korn shell both have function features not available in the POSIX standard shell.

## Local Variables

Bash and Korn shell functions can have local variables, making recursive functions possible. They are defined with the `typeset` command, as in

```
typeset i j
```

If a variable of the same name as a local function variable exists, it is saved when the `typeset` is executed and restored when the function exits. Note that the `typeset` command is not part of the POSIX standard shell.

After using the shell for a while, you may develop a set of functions that you like to use during your interactive work sessions. A good place to define such functions is inside your `ENV` file so that they will be defined whenever you start up a new shell.

## Automatically Loaded Functions

The Korn shell allows you to set up a special variable called `FPATH` that is similar to your `PATH` variable. If you try to execute a function that is not yet defined, the Korn shell searches the colon-delimited list of directories in your `FPATH` variable for a file that matches the function name. If it finds such a file, it executes it in the current shell. Presumably, somewhere inside the file will be a definition for the specified function.

## Integer Arithmetic

Both Bash and the Korn shell support evaluating arithmetic expressions without arithmetic expansion. The syntax is similar to `$(...)` but without the dollar sign. Because expansion is not performed, the construct can be used without variable assignment or the colon operator:

```
$ x=10
$ ((x = x * 12))
$ echo $x
120
$
```

The real value of this construct is that it allows arithmetic expressions to be used rather than `test` in `if`, `while`, and `until` commands. The comparison operators set the exit status to a nonzero value if the result of the comparison is false and to a zero value if the result is true. So writing

```
(( i == 100 ))
```

has the effect of testing `i` to see whether it is equal to 100 and setting the exit status appropriately. This knowledge makes integer arithmetic ideal for inclusion in `if` commands:

```
if (( i == 100 ))
then
    ...
fi
```

The `(( i == 100 ))` returns an exit status of zero (true) if `i` equals 100 and one (false) otherwise, and has the same effect as writing

```
if [ "$i" -eq 100 ]
then
    ...
fi
```

One advantage of using `((...))` rather than `test` is the capability to perform arithmetic as part of the test:

```
if (( i / 10 != 0 ))
then
    ...
fi
```

Here the comparison returns a true if `i` divided by 10 is not equal to zero.

`while` loops can also benefit from integer arithmetic. For example,

```
x=0
while ((x++ < 100))
do
    commands
done
```

executes *commands* 100 times. (Note that some older versions of the Korn shell and Bash do not support the `++` and `--` operators.)

## Integer Types

The Korn shell and Bash both support an integer data type. You can declare variables to be integers by using the `typeset` command with the `-i` option

```
typeset -i variables
```

where *variables* are any valid shell variable names. Initial values can be assigned to the variables at the time they are declared.

Arithmetic performed on integer variables with the `((...))` construct is slightly faster than on noninteger ones because the shell internally stores the value of an integer variable as a binary number and not as a character string.

An integer variable cannot be assigned anything but an integer value or an integer expression. If you attempt to assign a noninteger to it, the message `bad number` is printed by the Korn shell:

```
$ typeset -i i
$ i=hello
ksh: i: bad number
```

Bash simply ignores any strings that don't contain numeric values and generates an error for anything that contains both numbers and other characters:

```
$ typeset -i i
$ i=hello
$ echo $i
0
$ i=1hello
bash: 1hello: value too great for base (error token is "1hello")
$ i=10+15
$ echo $i
25
$
```

The preceding example shows that integer-valued expressions can be assigned to an integer variable, without even having to use the `((...))` construct. This holds true for both Bash and the Korn shell.

## Numbers in Different Bases

The Korn shell and Bash allow you to perform arithmetic in different bases. To write a number in a different base with these shells, you use the notation

```
base#number
```

For example, to express the value 100 in base 8 (octal) you write

```
8#100
```

You can write constants in different bases anywhere an integer value is permitted. To assign octal 100 to the integer variable `i`, you can write

```
typeset -i i=8#100
```

Note that with the Korn shell the base of the first value assigned to an integer variable fixes the base of all subsequent substitutions of that variable. In other words, if the first value you assign to the integer variable `i` is an octal number, each time you subsequently substitute the value of `i` on the command line, the Korn shell substitutes the value as an octal number using the notation `8#value`.

```
$ typeset -i i=8#100
```

```
$ echo $i
```

```
8#100
```

```
$ i=50
```

```
$ echo $i
```

```
8#62
```

```
$ (( i = 16#a5 + 16#120 ))
```

```
$ echo $i
```

```
8#705
```

```
$
```

Because the first value assigned to `i` in this example is an octal number (8#100), all further substitutions of `i` will be in octal. When the base 10 value of 50 is next assigned to `i` and then `i` is subsequently displayed, we get the value 8#62, which is the octal equivalent of 50 in base 10.

In the preceding example, the `((...))` construct is used to add together the two hexadecimal values `a5` and `120`. The result is then displayed, once again in octal.

Bash uses both the *base#number* syntax for arbitrary bases and the C language syntax for octal and hexadecimal numbers—octal numbers are preceded by `0` (zero), and hexadecimal numbers are preceded by `0x`:

```
$ typeset -i i=0100
```

```
$ echo $i
```

```
64
```

```
$ i=0x80
```

```
$ echo $i
```

```
128
```

```
$ i=2#1101001
```

```
$ echo $i
```

```
105
```

```
$ (( i = 16#a5 + 16#120 ))
```

```
$ echo $i
```

```
453
```

```
$
```

Unlike the Korn shell, Bash doesn't keep track of the variable's base; integer variables are displayed as decimal numbers. You can always use `printf` to print integers in octal or hexadecimal format.

As you can see, with Bash and the Korn shell it's easy to work with different bases. This makes it possible to easily write functions to perform base conversion and arithmetic, for example.

**Team LiB**

[◀ PREVIOUS](#)

[NEXT ▶](#)

## The `alias` Command

An *alias* is a shorthand notation provided by the shell to allow customization of commands. The shell keeps a list of aliases that is searched when a command is entered. If the first word of a command line is an alias, it is replaced by the text of the alias. An alias is defined by using the `alias` command. The format is

```
alias name=string
```

where *name* is the name of the alias, and *string* is any string of characters. For example,

```
alias ll='ls -l'
```

assigns `ls -l` to the alias `ll`. Now when the alias `ll` is typed in, the shell replaces it with `ls -l`. You can type arguments after the alias name on the command line, as in

```
ll *.c
```

which looks like this after alias substitution has been performed:

```
ls -l *.c
```

The shell performs its normal command-line processing both when the alias is set and when it is used, so quoting can be tricky. For example, recall that the shell keeps track of your current working directory inside a variable called `PWD`:

```
$ cd /users/steve/letters
```

```
$ echo $PWD
```

```
/users/steve/letters
```



```
$
```

You can create an alias called `dir` that gives you the base directory of your current working directory by using the `PWD` variable and one of the parameter substitution constructs described in an earlier section of this chapter:

```
alias dir="echo ${PWD##*/}"
```

Let's see how this alias works:

```
$ alias dir="echo ${PWD##*/}"           Define alias
$ pwd                                   Where are we?
/users/steve
$ dir                                   Execute alias
steve
$ cd letters                            Change directory
$ dir                                   Execute the alias again
steve
$ cd /usr/spool                         One more try
$ dir
steve
$
```

It seems that no matter what the current directory is, the `dir` alias prints out `steve`. That's because we weren't careful about our quotes when we defined the `dir` alias. Recalling that the shell performs parameter substitution inside double quotes, the shell evaluated

```
${PWD##*/}
```

at the time the alias was defined. This means, that for all intents and purposes, the `dir` alias was defined as though we typed in the following:

```
$ alias dir="echo steve"
```

The solution is to use single rather than double quotes when defining the `dir` alias to defer the parameter substitution until the time the alias is executed:

```
$ alias dir='echo ${PWD##*/}'           Define alias
$ pwd                                   Where are we?
/users/steve
$ dir                                   Execute alias
steve
$ cd letters                            Change directory
$ dir                                   Execute alias again
letters
$ cd /usr/spool                         One more try
$ dir
spool
$
```

Now the alias works just fine.

If an alias ends with a space, the word following the alias is also checked for alias substitution. For example:

```
alias nohup="/bin/nohup "  
nohup ll
```

causes the shell to perform alias checking on the string `ll` after replacing `nohup` with `/bin/nohup`.

Quoting a command prevents alias substitution. For example:

```
$ 'll'
ksh: ll: command not found
$
```

The format

```
alias name
```

causes the value of the alias *name* to be listed, and the `alias` command without arguments causes all aliases to be listed.

The following aliases are automatically defined when the Korn shell starts up:

```
autoload='typeset -fu'
functions='typeset -f'
history='fc -l'
integer='typeset -i'
local=typeset
nohup='nohup '
r='fc -e -'
suspend='kill -STOP $$'
```

Note from the preceding example that `r` is actually an alias for the `fc` command with the `-e` option, and `history` is an alias for `fc -l`. Bash doesn't automatically define any aliases by default.

## Removing Aliases

The `unalias` command is used to remove aliases from the alias list. The format is

```
unalias name
```

which removes the alias *name* and

```
unalias -a
```

which removes all aliases.

This concludes this section on aliases. If you develop a set of alias definitions that you like to use during your login sessions, you may want to define them inside your `ENV` file so that they will always be available for you to use.

# Arrays

The Korn shell and Bash provide a limited array capability (arrays are not a part of the POSIX standard shell). Bash arrays may contain an unlimited number of elements (subject to memory limitations); Korn shell arrays are limited to 4096 elements. Array indexing in both shells starts at zero. An array element is accessed with a *subscript*, which is an integer-valued expression enclosed inside a pair of brackets. You don't declare the maximum size of a shell array; you simply assign values to elements as you need them. The values that you can assign are the same as for ordinary variables.

```
$ arr[0]=hello
$ arr[1]="some text"
$ arr[2]=/users/steve/memos
$
```

To retrieve an element from an array, you write the array name followed by the element number, enclosed inside a pair of brackets as before. The entire construct must be enclosed inside a pair of curly braces, which is then preceded by a dollar sign.

```
$ echo ${array[0]}
hello
$ echo ${array[1]}
some text
$ echo ${array[2]}
/users/steve/memos
$ echo $array
hello
$
```

As you can see from the preceding example, if no subscript is specified, element zero is used.

If you forget the curly braces when performing the substitution, here's what happens:

```
$ echo $array[1]
```

```
hello[1]
```

```
$
```

In the preceding example, the value of `array` is substituted (`hello`—the value inside `array[0]`) and then echoed along with `[1]`. (Note that because the shell does filename substitution after variable substitution, the shell would attempt to match the pattern `hello[1]` against the files in your current directory.)

The construct `[*]` can be used as a subscript to substitute all the elements of the array on the command line, with each element delimited by a single space character.

```
$ echo ${array[*]}
```

```
hello some text /users/steve/memos
```

```
$
```

The construct `${#array[*]}` can be used to substitute the number of elements in the array `array`.

```
$ echo ${#array[*]}
```

```
3
```

```
$
```

Note that the number reported here is the actual number of values stored inside the array, not the largest subscript used to store an element inside the array.

```
$ array[10]=foo
```

```
$ echo ${array[*]}           Display all elements
```

```
hello some text /users/steve/memos foo
```

```
$ echo ${#array[*]}           Number of elements
```

```
4
```

```
$
```

You can declare an array of integers to the shell simply by giving the array name to `typeset -i`:

```
typeset -i data
```

Integer calculations can be performed on array elements using the `((...))` construct:

```
$ typeset -i array
```

```
$ array[0]=100
```

```
$ array[1]=50
```

```
$ (( array[2] = array[0] + array[1] ))
```

```
$ echo ${array[2]}
```

```
150
```

```
$ i=1
```

```
$ echo ${array[i]}
```

```
50
```

```
$ array[3]=array[0]+array[2]
```

```
$ echo ${array[3]}
```

```
250
```

```
$
```

Note that not only can you omit the dollar signs and the curly braces when referencing array elements inside double parentheses, you also can omit them outside when the array is declared to be

of integer type. Also note that dollar signs are not needed before variables used in subscript expressions.

The following program, called `reverse`, reads in up to 4096 lines from standard input and then writes them back out to standard output in reverse order:

```
$ cat reverse

# read lines to array buf

typeset -i line=0

while (( line < 4096 )) && read buf[line]
do
    (( line = line + 1 ))
done

# now print the lines in reverse order

while (( line > 0 )) do
    (( line = line - 1 ))
    echo "${buf[line]}"
done

$ reverse

line one

line two

line three

Ctrl+d
```





```

while ((i < cdlen))
do
    printf "%3d %s\n" $i ${CDHIST[i]}
    ((i = i + 1))
done
return ;;

-[0-9]|-[0-9][0-9])          # cd to dir in list
i=${1#-}                    # remove leading '-'
cd ${CDHIST[i]} ;;

*)                            # cd to new dir

cd $@ ;;

esac

CDHIST[cdlen]=$PWD
}
$

```

The `CDHIST` array stores each directory visited by `cdh`, and the first element, `CDHIST[0]`, is initialized with the current directory when the `cdh` file is run:

```

$ pwd
/users/pat
$ . cdh          Define cdh function
$ cdh /tmp
$ cdh -l
0 /users/pat
1 /tmp

```

```
$
```

When the `cdh` file was run, `CDHIST[0]` was assigned `/users/pat`, and the `cdh` function was defined; when `cdh /tmp` was executed, `cdlen` was assigned the number of elements in `CDHIST` (one), and `CDHIST[1]` was assigned `/tmp`. The `cdh -l` caused `printf` to display each element of `CDHIST` (on this invocation, `cdlen` was set to 2, because elements 0 and 1 of `CDHIST` contained data).

Note that the `if` statement at the beginning of the function sets `$1` to `$HOME` if no arguments are passed. Let's try that out:

```
$ cdh
```

```
$ pwd
```

```
/users/pat
```

```
$ cdh -l
```

```
0 /users/pat
```

```
1 /tmp
```

```
2 /users/pat
```

```
$
```

Well, it worked, but now `/users/pat` shows up twice in the list. One of the exercises at the end of this chapter asks you to remedy this.

Okay, the most useful feature of `cdh` is the `-r` option, which causes it to change the current directory to the one specified in the list:

```
$ cdh /usr/spool/uucppublic
```

```
$ cdh -l
```

```
0 /users/pat
```

```
1 /tmp
```

```
2 /users/pat
```

```
3 /usr/spool/uucppublic
```

```
$ cdh -1
```

```
$ pwd
```

```
/tmp
```

```
$ cdh -3
```

```
$ pwd
```

```
/usr/spool/uucppublic
```

```
$
```

We can make `cdh` replace our `cd` command by using the fact that alias lookup is performed before built-in commands are executed. So if we create a `cd` alias to `cdh`, we can have an enhanced `cd`. In that case, we have to quote every use of `cd` in the `cdh` function to prevent recursion:

```
$ cat cdh
```

```
CDHIST[0]=$PWD                                # initialize CDHIST[0]
```

```
alias cd=cdh
```

```
cdh ()
```

```
{
```

```
    typeset -i cdlen i
```

```
    if [ $# -eq 0 ]                            # default to HOME with no arguments
```

```
    then
```

```
        set -- $HOME
```

```
    fi
```

```
    cdlen=${#CDHIST[*]}                        # number of elements in CDHIST
```

```
    case "$@" in
```

```

-1)                                # print directory list

    i=0

    while ((i < cdlen))

    do

        printf "%3d %s\n" $i ${CDHIST[i]}

        ((i = i + 1))

    done

    return ;;

-[0-9]|-[0-9][0-9])                # cd to dir in list

    i=${1#-}                          # remove leading '-'

    'cd' ${CDHIST[i]} ;;

*)                                    # cd to new dir

    'cd' $@ ;;

esac

    CDHIST[cdlen]=$PWD

}

$ . cdh                                Define cdh function and cd alias

$ cd /tmp

$ cd -l

    0 /users/pat

    1 /tmp

$ cd /usr/spool

$ cd -l

    0 /users/pat

    1 /tmp

```

```
2 /usr/spool
```

```
$
```

[Table 15.3](#) summarizes the various array constructs in the Korn shell and Bash.

Table 15.3. Array Constructs

Construct	Meaning
<code>\${array[i]}</code>	Substitute value of element <i>i</i>
<code>\$array</code>	Substitute value of first element ( <code>array[0]</code> )
<code>\${array[*]}</code>	Substitute value of all elements
<code>\${#array[*]}</code>	Substitute number of elements
<code>array[i]=val</code>	Store <i>val</i> into <code>array[i]</code>

Team LiB

◀ PREVIOUS

NEXT ▶

## Job Control

The shell provides facilities for controlling *jobs*. A job is any command sequence. For example:

```
who | wc
```

When a command is started in the background (that is, with `&`), the shell prints out the job number inside brackets (`[ ]`) as well as the process number:

```
$ who | wc &
[1]      832
$
```

When a job finishes, the shell prints the message

```
[n] +      sequence
```

where *n* is the job number of the finished job, and *sequence* is the text of the command sequence used to create the job.

The `jobs` command may be used to print the status of jobs that haven't yet finished.

```
$ jobs
[3] +  Running      make ksh &
[2] -  Running      monitor &
[1]   Running      pic chapt2 | troff > aps.out &
```

The `+` and `-` after the job number mark the current and previous jobs, respectively. The current job is

the last job sent to the background, and the previous job is the next-to-the-last job sent to the background. Several built-in commands may be given a job number or the current or previous job as arguments.

The shell's built-in `kill` command can be used to terminate a job running in the background. The argument to it can be a process number or a percent sign (`%`) followed by a job number, a `+` (current job), a `-` (previous job), or another `%` (also current job).

```
$ pic chapt1 | troff > aps.out &
[1]      886
$ jobs
[1] +  Running          pic chapt1 | troff > aps.out &
$ kill %1
[1]  Done              pic chapt1 | troff > aps.out &
$
```

The preceding `kill` could have used `%+` or `%%` to refer to the same job.

The first few characters of the command sequence can also be used to refer to a job; for example, `kill %pic` would have worked in the preceding example.

## Stopped Jobs and the `fg` and `bg` Commands

If you are running a job in the foreground (without an `&`) and you want to suspend it, you can press the `Ctrl+z` key. The job stops executing, and the shell prints the message

```
[n] + Stopped (SIGTSTP)  sequence
```

The stopped job is made the current job. To have it continue executing, you must use the `fg` or `bg` command. The `fg` command with no arguments causes the current job to resume execution in the foreground, and `bg` causes the current job to resume execution in the background. You can also use a job number, the first few characters of the pipeline, a `+`, a `-`, or a `%` preceded by a `+` to specify any job to the `fg` and `bg` commands. These commands print out the command sequence to remind you what is being brought to the foreground or sent to the background.



```
$ troff memo | photo
```

```
Ctrl+z
```

```
[1] + Stopped (SIGTSTP)      troff memo | photo
```

```
$ bg
```

```
[1]      troff memo | photo &
```

```
$
```

The preceding sequence is one of the most often used with job control: sending a job mistakenly started in the foreground to the background.

If a job running in the background tries to read from the terminal, it is stopped, and the message

```
[n] - Stopped (SIGTTIN)  sequence
```

is printed. It can then be brought to the foreground with the `fg` command. After entering input to the job, it can be stopped (with the `Ctrl+z`) and returned to the background until it again requests input from the terminal.

Output from a background job normally goes directly to the terminal. The command

```
stty tostop
```

causes any background job that attempts to write to the terminal to be stopped and the message

```
[n] - Stopped (SIGTTOU)  sequence
```

to be printed. (Note that Bash generates slightly different messages than the ones shown here.)

The following shows how job control might be used:

```
$ stty tostop
```

```
$ rundb           Start up data base program

??? find green red      Find green and red objects

Ctrl+z           This may take a while

[1] + Stopped      rundb

$ bg              So put it in the background

[1]      rundb &

...             Do some other stuff

$ jobs

[1] + Stopped(tty output)      rundb &

$ fg              Bring back to foreground

rundb

1973 Ford      Mustang      red
1975 Chevy     Monte Carlo  green
1976 Ford      Granada      green
1980 Buick     Century      green
1983 Chevy     Cavalier     red

??? find blue      Find blue objects

Ctrl+z           Stop it again

[1] + Stopped      rundb

$ bg              Back to the background

[1]      rundb &

...             Keep working until it's ready
```



```

cat                                Harmless commands

echo

ls

mail                                Let them send us mail

red                                Restricted editor

write

$ ls /users/restrict/bin          restrict's command directory

adventure                          Lots of games

backgammon

chess

hearts

poker

rogue

$

```

Here we have a restricted environment for a user. When this user logs in, his `PATH` is changed to search just the directories `/usr/rbin` and `/users/restrict/bin`. He can run only commands found in these two directories. Any other command will get a `command: not found` response. The user is effectively bottled up in the directory `/users/restrict/restdir` and cannot `cd` out of it. The `.profile` is owned by a user other than the restricted one, and the permissions are such that only the owner can change the file. (Don't let a restricted user alter his or her `.profile` because the `.profile` is executed before any restrictions are applied.)

One quick note about the commands in `/usr/rbin`: They were simply copied from the `/bin` and `/usr/bin` directories. You can put almost any command from `/bin` and `/usr/bin` in `/usr/rbin`; just use common sense in choosing the commands you allow restricted users to use. For example, don't give them access to the shell, a compiler, or `chmod` because these may be used to bypass the restricted shell. The `mail` and `write` commands are safe even though they have shell escapes because the shell looks at the `SHELL` variable and runs restricted if the first character of its name is "r." The restricted editor `red` is the same as `ed`, except it doesn't allow shell escapes, and it only allows editing of files in the current directory.

Note that most restricted shells are not really very secure. They should not be used to contain hostile users. Even though some restricted shells are more secure than others, if you give a restricted user certain commands (such as `env`), he will be able to break out into a nonrestricted shell.

If you can't find the restricted shell on your system, you can copy or link your Bash, Korn shell, or

even old Bourne shell to any filename that begins with "r" and make that file the login shell of the restricted user. When the shell starts up, it checks the first letter of the command name that was used to invoke it; if that letter is "r," it will be a restricted shell.

**Team LiB**

[◀ PREVIOUS](#)

[NEXT ▶](#)

# Miscellaneous Features

## Other Features of the `cd` Command

The `-` argument to `cd` always means "the previous directory."

```
$ pwd
```

```
/usr/src/cmd
```

```
$ cd /usr/spool/uucp
```

```
$ pwd
```

```
/usr/spool/uucp
```

```
$ cd - cd to previous directory
```

```
/usr/src/cmd cd prints out name of new directory
```

```
$ cd -
```

```
/usr/spool/uucp
```

```
$
```

As you can see, `cd -` can be used to toggle between two directories with no effort at all.

The Korn shell's `cd` command has the capability to substitute portions of the current directory's path with something else. (Bash and the POSIX standard shell do not support this feature.) The format is

```
cd old new
```

`cd` attempts to replace the first occurrence of the string *old* in the current directory's path with the string *new*.

```
$ pwd
```

```
/usr/spool/uucppublic/pat
```

```
$ cd pat steve Change pat to steve and cd
```

```
/usr/spool/uucppublic/steve cd prints out name of new directory
```

```
$ pwd Confirm location
```

```
/usr/spool/uucppublic/steve
```

```
$
```

## Tilde Substitution

If a word on a command line begins with the tilde (~) character, the shell scans the rest of the word and performs the following substitutions: If the tilde is the only character in the word or if the character following the tilde is a slash (/), the value of the **HOME** variable is substituted:

```
$ echo ~
```

```
/users/pat
```

```
$ grep Korn ~/shell/chapter9/ksh
```

```
The Korn shell is a new shell developed
```

```
by David Korn at AT&T
```

```
for the Bourne shell would also run under the Korn
```

```
the one on System V, the Korn shell provides you with
```

```
idea of the compatibility of the Korn shell with Bourne's,
```

```
the Bourne and Korn shells.
```

```
The main features added to the Korn shell are:
```

```
$
```

If the rest of the word up to a slash is a user's login name in `/etc/passwd`, the tilde and the user's login name are substituted with the **HOME** directory of that user.

```
$ echo ~steve
```

```
/users/steve
```

```
$ echo ~pat
```

```
/users/pat
```

```
$ grep Korn -pat/shell/chapter9/ksh
```

The Korn shell is a new shell developed

by David Korn at AT&T

for the Bourne shell would also run under the Korn

the one on System V, the Korn shell provides you with

idea of the compatibility of the Korn shell with Bourne's,

the Bourne and Korn shells.

The main features added to the Korn shell are:

```
$
```

In the Korn shell and Bash, if the ~ is followed by a + or a -, the value of the variable `PWD` or `OLDPWD` is substituted, respectively. `PWD` and `OLDPWD` are set by `cd` and are the full pathnames of the current and previous directories, respectively. `~+` and `~-` are not supported by the POSIX standard shell.

```
$ pwd
```

```
/usr/spool/uucppublic/steve
```

```
$ cd
```

```
$ pwd
```

```
/users/pat
```

```
$ echo ~+
```

```
/users/pat
```

```
$ echo ~-
```

```
/usr/spool/uucppublic/steve
```



\$

In addition to the preceding substitutions, the shell also checks for a tilde after a colon (:) and performs tilde substitution on that as well (for `PATH` interpretation).

## Order of Search

It's worthwhile listing the order of searching the shell uses when you type a command name:

1. The shell first checks to see whether the command is a reserved word (such as `for` and `do`).
2. If it's not a reserved word and is not quoted, the shell next checks its alias list, and if it finds a match, performs the substitution. If the alias definition ends in a space, it attempts alias substitution on the next word. The final result is then checked against the reserved word list, and if it's not a reserved word, the shell proceeds to step 3.
3. Next, the shell checks the command against its function list and executes it if found.
4. The shell checks to see whether the command is a built-in command (such as `cd` and `pwd`).
5. Finally, the shell searches the `PATH` to locate the command.
6. If the command still isn't found, a "`command not found`" error message is issued.

## Compatibility Summary

[Table 15.4](#) summarizes the compatibility of the POSIX standard shell, the Korn shell, and Bash with the features described in this chapter. In this table, an "X" denotes a supported feature, "UP," an optional feature in the POSIX shell (these are also known as "User Portability" features in the POSIX shell specification), and "POS," a feature supported only by Bash when it is invoked with the name `sh` or with the `--posix` command-line option, or after `set -o posix` is executed.

Table 15.4. POSIX Shell, Korn Shell, and Bash Compatibility

	POSIX Shell	Korn Shell	Bash
<code>ENV</code> file	X	X	POS
<code>vi</code> line edit mode	X	X	X
<code>emacs</code> line edit mode		X	X
<code>fc</code> command	X	X	X
<code>r</code> command		X	
<code>!!</code>			X
<code>!string</code>			X
Functions	X	X	X
local variables		X	X
autoload via <code>FPATH</code>		X	
Integer expressions with <code>((...))</code>		X	X
Integer data type		X	X
integers in different bases		X	X
<code>0xhexnumber</code> , <code>0octalnumber</code>			X
Aliases	UP	X	X
Arrays		X	X
Job control	UP	X	X
<code>cd -</code>	X	X	X
<code>cd old new</code>		X	

*~username, ~/*

*~+, ~-*

**Team LiB**

POSIX Shell	Korn Shell	Bash
-------------	------------	------

X	X	X
---	---	---

	X	X
--	---	---

**◀ PREVIOUS**

**NEXT ▶**

## Exercises

- 1: Using only shell built-in commands, write a function that prints all filenames in a specified directory hierarchy. Its output should be similar to the output of the `find` command:

```
$ myfind /users/pat
/users/pat
/users/pat/bin
/users/pat/bin/ksh
/users/pat/bin/lf
/users/pat/bin/pic
/users/pat/chapt1
/users/pat/chapt1/intro
/users/pat/rje
/users/pat/rje/file1
```

(Hint: Bash and Korn shell functions can be recursive.)

- 2: Write a shell function called `octal` that converts octal numbers given as command-line arguments to decimal numbers and prints them out, one per line:

```
$ octal 10 11 12
8
9
10
$
```

(Hint for Korn shell users: If you assign a decimal number to a variable when it's declared—for example, `typeset -i d=10#0`—assignments to this variable from other bases are converted to decimal first.)

- 3: Modify the `cdh` function to filter out multiple occurrences of the same directory; for example:

```
$ cdh -l
0 /users/pat

$ cdh

$ cdh

$ cdh -l
0 /users/pat

$
```

- 4: Modify the `cdh` function to set the prompt (`PS1`) to show the current directory; for example:

```
/users/pat: cdh /tmp

/tmp: cdh

/users/pat:
```

- 5: Modify the `cdh` function to allow the user to specify a partial name of a directory in the history file preceded by a dash:

```
/etc: cdh -l

0 /users/pat

1 /tmp

2 /users/steve

3 /usr/spool/uucppublic
```

```
4 /usr/local/bin
```

```
5 /etc
```

```
/etc: cdh -pub
```

```
/usr/spool/uucppublic: cdh -bin
```

```
/usr/local/bin:
```

6: (Bash users only) Add the Korn shell's `cd old new` feature to the `cdh` function.

Team LiB

◀ PREVIOUS

NEXT ▶

# Appendix A. Shell Summary

IN THIS APPENDIX

- [Startup](#)
- [Commands](#)
- [Comments](#)
- [Parameters and Variables](#)
- [Command Re-entry](#)
- [Quoting](#)
- [Filename Substitution](#)
- [I/O Redirection](#)
- [Exported Variables and Subshell Execution](#)
- [Functions](#)
- [Job Control](#)
- [Command Summary](#)

This appendix summarizes the main features of the standard POSIX shell as per IEEE Std 1003.1-2001.

## Startup

The shell can be given the same options on the command line as can be specified with the `set` command. In addition, the following options can be specified:

- `-c commands` *commands* are executed.
- `-i` The shell is interactive. Signals 2, 3, and 15 are ignored.
- `-s` Commands are read from standard input.



# Commands

The general format of a command typed to the shell is

*command arguments*

where *command* is the name of the program to be executed, and *arguments* are its arguments. The command name and the arguments are delimited by *whitespace* characters, normally the space, tab, and newline characters (changing the variable `IFS` affects this).

Multiple commands can be typed on the same line if they're separated by semicolons (;).

Every command that gets executed returns a number known as the *exit status*, zero is used to indicate success, and nonzero indicates a failure.

The pipe symbol | can be used to connect the standard output from one command to the standard input of another, as in

```
who | wc -l
```

The exit status is that of the last command in the pipeline. Placing a ! at the beginning of the pipeline causes the exit status of the pipeline to be the logical negation of the last command in the pipeline.

If the command sequence is terminated by an ampersand character (&), it is run asynchronously in the background. The shell displays the process id number and job id of the command at the terminal.

Typing of a command can continue to the next line if the last character on the line is a backslash character (\).

The characters && cause the command that follows to be executed only if the preceding command returns a zero exit status. The characters || cause the command that follows to be executed only if the preceding command returns a nonzero exit status. As an example, in

```
who | grep "fred" > /dev/null && echo "fred's logged on"
```

the `echo` is executed only if the `grep` returns a zero exit status.

## Comments

If a word begins with the character #, the shell treats the remainder of the line as a comment and simply ignores it.

# Parameters and Variables

There are three different "types" of *parameters*: shell variables, special parameters, and positional parameters.

## Shell Variables

A shell variable name must start with an alphabetic or underscore (`_`) character, and can be followed by any number of alphanumeric or underscore characters. Shell variables can be assigned values on the command line by writing:

```
variable=value variable=value ...
```

Filename substitution is not performed on *value*.

## Positional Parameters

Whenever a shell program is executed, the name of the program is assigned to the variable `$0` and the arguments typed on the command line to the variables `$1`, `$2`, and `...`, respectively. Positional parameters can also be assigned values with the `set` command. Parameters 1 through 9 can be explicitly referenced. Parameters greater than nine must be enclosed inside braces, as in `${10}`.

## Special Parameters

[Table A.1](#) summarizes the special shell parameters.

Table A.1. Special Parameter Variables

Parameter	Meaning
<code>\$#</code>	The number of arguments passed to the program; or the number of parameters set by executing the <code>set</code> statement
<code>\$*</code>	Collectively references all the positional parameters as <code>\$1</code> , <code>\$2</code> , <code>...</code>
<code>\$@</code>	Same as <code>\$*</code> , except when double-quoted (" <code>\$@"</code> ") collectively references all the positional parameters as " <code>\$1</code> ", " <code>\$2</code> ", <code>...</code>
<code>\$0</code>	The name of the program being executed
<code>\$\$</code>	The process id number of the program being executed

Parameter	Meaning
\$!	The process id number of the last program sent to the background for execution
\$?	The exit status of the last command not executed in the background
\$-	The current option flags in effect (see the <a href="#">set statement</a> )

In addition to these parameters, the shell has some other variables that it uses. [Table A.2](#) summarizes the more important of these variables.

Table A.2. Other Variables Used by the Shell

Variable	Meaning
<code>CDPATH</code>	The directories to be searched whenever <code>cd</code> is executed without a full path as argument.
<code>ENV</code>	The name of a file that the shell executes in the current environment when started interactively.
<code>FCEDIT</code>	The editor used by <code>fc</code> . If not set, <code>ed</code> is used.
<code>HISTFILE</code>	If set, it specifies a file to be used to store the command history. If not set or if the file isn't writable, <code>\$HOME/.sh_history</code> is used.
<code>HISTSIZE</code>	If set, specifies the number of previously entered commands accessible for editing. The default value is at least 128.
<code>HOME</code>	The user's home directory; the directory that <code>cd</code> changes to when no argument is supplied.
<code>IFS</code>	The Internal Field Separator characters; used by the shell to delimit words when parsing the command line, for the <code>read</code> and <code>set</code> commands, when substituting the output from a back-quoted command, and when performing parameter substitution. Normally, it contains the three characters space, horizontal tab, and newline.
<code>LINENO</code>	Set by the shell to the line number in the script it is executing. This value is set before the line gets executed and starts at 1.
<code>MAIL</code>	The name of a file that the shell periodically checks for the arrival of mail. If new mail arrives, the shell displays a <code>You have mail</code> message. See also <code>MAILCHECK</code> and <code>MAILPATH</code> .
<code>MAILCHECK</code>	The number of seconds specifying how often the shell is to check for the arrival of mail in the file in <code>MAIL</code> or in the files listed in <code>MAILPATH</code> . The default is 600. A value of 0 causes the shell to check before displaying each command prompt.

Variable	Meaning
<code>MAILPATH</code>	A list of files to be checked for the arrival of mail. Each file is delimited by a colon and can be followed by a percent sign (%) and a message to be displayed when mail arrives in the indicated file. ( <code>You have mail</code> is often the default.)
<code>PATH</code>	A colon-delimited list of directories to be searched when the shell needs to find a command to be executed. The current directory is specified as <code>::</code> or <code>.::</code> (if it heads or ends the list, <code>:</code> suffices).
<code>PPID</code>	The process id number of the program that invoked this shell (that is, the parent process).
<code>PS1</code>	The primary command prompt, normally " <code>\$</code> ".
<code>PS2</code>	The secondary command prompt, normally " <code>&gt;</code> ".
<code>PS4</code>	Prompt used during execution trace ( <code>-x</code> option to shell or <code>set -x</code> ). Default is " <code>+</code> ".
<code>PWD</code>	Pathname of the current working directory.

## Parameter Substitution

In the simplest case, the value of a parameter can be accessed by preceding the parameter with a dollar sign (`$`). [Table A.3](#) summarizes the different types of parameter substitution that can be performed. Parameter substitution is performed by the shell before filename substitution and before the command line is divided into arguments.

The presence of the colon after *parameter* in [Table A.3](#) indicates that *parameter* is to be tested to see whether it's set and not null. Without the colon, a test is made to check whether *parameter* is set only.

Table A.3. Parameter Substitution

Parameter	Meaning
<code>\$parameter</code> or <code>\${parameter}</code>	Substitute the value of <i>parameter</i> .
<code>\${parameter:-value}</code>	Substitute the value of <i>parameter</i> if it's set and non-null; otherwise, substitute <i>value</i> .
<code>\${parameter- value}</code>	Substitute the value of <i>parameter</i> if it's set; otherwise, substitute <i>value</i> .
<code>\${parameter:=value}</code>	Substitute the value of <i>parameter</i> if it's set and non-null; otherwise, substitute <i>value</i> and also assign it to <i>parameter</i> .
<code>\${parameter= value}</code>	Substitute the value of <i>parameter</i> if it's set; otherwise, substitute <i>value</i> and also assign it to <i>parameter</i> .

Parameter	Meaning
<code>\${parameter:? value}</code>	Substitute the value of <i>parameter</i> if it's set and non-null; otherwise, write <i>value</i> to standard error and exit. If <i>value</i> is omitted, write <i>parameter: parameter null or not set</i> instead.
<code>\${parameter? value}</code>	Substitute the value of <i>parameter</i> if it's set; otherwise, write <i>value</i> to standard error and exit. If <i>value</i> is omitted, write <i>parameter: parameter null or not set</i> instead.
<code>\${parameter+ value}</code>	Substitute <i>value</i> if <i>parameter</i> is set and non-null; otherwise, substitute null.
<code>\${parameter+}</code>	Substitute <i>value</i> if <i>parameter</i> is set; otherwise, substitute null.
<code>\${#parameter}</code>	Substitute the length of <i>parameter</i> . If <i>parameter</i> is <i>*</i> or <i>@</i> , the result is not specified.
<code>\${parameter#pattern}</code>	Substitute the value of <i>parameter</i> with <i>pattern</i> removed from the left side. The smallest portion of the contents of <i>parameter</i> matching <i>pattern</i> is removed. Shell filename substitution characters ( <i>*</i> , <i>?</i> , [...], <i>!</i> , and <i>@</i> ) may be used in <i>pattern</i> .
<code>\${parameter##pattern}</code>	Same as <i>#pattern</i> except the largest matching <i>pattern</i> is removed.
<code>\${parameter%pattern}</code>	Same as <i>#pattern</i> except <i>pattern</i> is removed from the right side.
<code>\${parameter%%pattern}</code>	Same as <i>##pattern</i> except the largest matching <i>pattern</i> is removed from the right side.

## Command Re-entry

The shell keeps a list, or history, of recently entered commands. The number of commands available is determined by the `HISTSIZE` variable (default at least 128), and the file in which the history is kept is determined by the `HISTFILE` variable (default `$HOME/.sh_history`). Because the command history is stored in a file, these commands are available after you log off and back on.

There are three ways you can access the command history.

### The `fc` Command

The built-in command `fc` allows you to run an editor on one or more commands in the command history. When the edited command(s) is written and you leave the editor, the edited version of the command(s) is executed. The editor is determined by the `FCEDIT` variable (default `ed`). The `-e` option may be used with `fc` to specify the editor rather than `FCEDIT`.

The `-s` option causes commands to be executed without first invoking an editor. A simple editing capability is built in to the `fc -s` command; an argument of the form

*old=new*

may be used to change the first occurrence of the string *old* to the string *new* in the command(s) to be re-executed.

### `vi` Line Edit Mode

The shell has a built-in implementation of the `vi` screen editor, scaled down to work on single lines. When `vi` mode is turned on, you are by default placed in a state similar to `vi`'s *input* mode. Commands can be typed just the same as when `vi` mode is off. At any time, however, you can press the Esc key to be placed in *edit* mode. At this point, most `vi` commands will be interpreted by the shell. The current command line can be edited, as can any of the lines in the command history. Pressing Enter at any point in either command or input mode causes the command being edited to be executed.

[Table A.4](#) lists all the editing commands in `vi` mode. Note: `[count]` is any integer and may be omitted.

Table A.4. `vi` Editing Commands

#### Input Mode Commands

Command	Meaning
---------	---------

<i>erase</i>	(Erase character, usually <i>Ctrl+h</i> or <i>#</i> ); delete previous character.
<i>Ctrl+w</i>	Delete the previous blank-separated word.
<i>kill</i>	(Line kill character, normally <i>Ctrl+u</i> or <i>@</i> ); delete the entire current line.
<i>eof</i>	(End-of-file character, normally <i>Ctrl+d</i> ); terminate the shell if the current line is empty.
<i>Ctrl+v</i>	Quote next character; editing characters and the erase and kill characters may be entered in a command line or in a search string if preceded by a <i>Ctrl+v</i> .
Enter	Execute the current line.
<i>Esc</i>	Enter edit mode.

### Edit Mode Commands

Command	Meaning
[ <i>count</i> ]k	Get previous command from history.
[ <i>count</i> ]-	Get previous command from history.
[ <i>count</i> ]j	Get next command from history.
[ <i>count</i> ]+	Get next command from history.
[ <i>count</i> ]G	Get the command number <i>count</i> from history; the default is the oldest stored command.
<i>/ string</i>	Search history for the most recent command containing <i>string</i> , if <i>string</i> is null, the previous string will be used ( <i>string</i> is terminated by an Enter or a <i>Ctrl+j</i> ); if <i>string</i> begins with <i>^</i> , search for line beginning with <i>string</i> .
? <i>string</i>	Same as <i>/</i> except that the search will be for the least recent command.
n	Repeat the last <i>/</i> or ? command.
N	Repeat the last <i>/</i> or ? command but reverse the direction of the search.
[ <i>count</i> ]l or [ <i>count</i> ]space	Move cursor right one character.
[ <i>count</i> ]w	Move cursor right one alphanumeric word.
[ <i>count</i> ]W	Move cursor right to next blank-separated word.
[ <i>count</i> ]e	Move cursor to end of word.
[ <i>count</i> ]E	Move cursor to end of current blank-separated word.
[ <i>count</i> ]h	Move cursor left one character.
[ <i>count</i> ]b	Move cursor left one word.
[ <i>count</i> ]B	Move cursor left to previous blank-separated word.
0	Move cursor to start of line.
^	Move cursor to first nonblank character.



\$	Move cursor to end of line.
[count]/	Move cursor to column <i>count</i> , 1 is default.
[count]f c	Move cursor right to character <i>c</i> .
[count]F c	Move cursor left to character <i>c</i> .
[count]t c	Same as f c followed by h.
[count]T c	Same as F c followed by l.
;	Repeat the last f, F, t, or T command.
,	Reverse of ;.
a	Enter input mode and enter text after the current character.
A	Append text to the end of the line; same as \$a.
[count]c motion	Delete current character through character specified by <i>motion</i> and enter input mode; if <i>motion</i> is c, the entire line is deleted.
C	Delete current character through end of line and enter input mode.
S	Same as cc.
[count]d motion	Delete current character through the character specified by <i>motion</i> , if <i>motion</i> is d, the entire line is deleted.
D	Delete current character through the end of line; same as d\$.
i	Enter input mode and insert text before the current character.
I	Enter input mode and insert text before the first word on the line.
[count]P	Place the previous text modification before the cursor.
[count]p	Place the previous text modification after the cursor.
[count]y motion	Copy current character through character specified by <i>motion</i> into buffer used by p and P; if <i>motion</i> is y, the entire line is copied.
Y	Copy current character through the end of line; same as y\$.
R	Enter input mode and overwrite characters on the line.
[count]r c	Replace the current character with <i>c</i> .
[count]x	Delete current character.
[count]X	Delete preceding character.
[count].	Repeat the previous text modification command.
~	Invert the case of the current character and advance the cursor.
[count]_	Append the <i>count</i> word from the previous command and enter input mode; the last word is the default.
*	Attempt filename generation on the current word; if a match is found, replace the current word with the match and enter input mode.

=	List files that begin with current word.
\	Complete pathname of current word; if current word is a directory, append a /; if current word is a file, append a space.
u	Undo the last text modification command.
U	Restore the current line to its original state.
@ <i>letter</i>	Soft function key—if an alias of the name <i>_letter</i> is defined, its value will be executed.
[ <i>count</i> ]v	Execute <b>vi</b> editor on line <i>count</i> ; if <i>count</i> is omitted, the current line is used.
Ctrl+l	Linefeed and print current line.
L	Reprint the current line.
Ctrl+j	Execute the current line.
Ctrl+m	Execute the current line.
Enter	Execute the current line.
#	Insert a # at the beginning of the line and enter the line into the command history (same as <b>I#Enter</b> ).

## Quoting

Four different types of quoting mechanisms are recognized. These are summarized in [Table A.5](#).

Table A.5. Summary of Quotes

Quote	Description
'...'	Removes special meaning of all enclosed characters
"..."	Removes special meaning of all enclosed characters except \$, `, and \
\c	Removes special meaning of character c that follows; inside double quotes removes special meaning of \$, `, ", newline, and \ that follows, but is otherwise not interpreted; used for line continuation if appears as last character on line (newline is removed)
<code>`command`</code> or <code>\$(command)</code>	Executes <i>command</i> and inserts standard output at that point

## Tilde Substitution

Each word and shell variable on a command line is checked to see whether it begins with an unquoted ~. If it does, the rest of the word or variable up to a / is considered a login name and is looked up in a system file, typically `/etc/passwd`. If that user exists, his home directory replaces the ~ and his login name. If that user doesn't exist, the text is unchanged. A ~ by itself or followed by a / is replaced by the `HOME` variable.

## Arithmetic Expressions

*General Format:* `$( ( expression ) )`

The shell evaluates the integer arithmetic *expression*. *expression* can contain constants, shell variables (which don't have to be preceded by dollar signs), and operators. The operators, in order of decreasing precedence, are

-	unary minus
~	bitwise NOT
!	logical negation
* / %	multiplication, division, remainder
+ -	addition, subtraction
<< >>	left shift, right shift
<= >= < >	comparison
== !=	equal, not equal
&	bitwise AND
^	bitwise exclusive OR
	bitwise OR
&&	logical AND
	logical OR
<i>expr<sub>1</sub>? expr<sub>2</sub>: expr<sub>3</sub></i>	conditional operator
=, *=, /=, %=	assignment
+=, <<=, >>=, &=,	
^=,  =	

Parentheses may be used to override operator precedence.

The exit status is zero (true) if the last expression is nonzero and one (false) if the last expression is zero.

The C operators `sizeof`, `++`, and `--` may be available in your shell implementation but are not required by the standard.

### Examples

```
y=$((22 * 33))
```

```
z=$((y * y / (y - 1)))
```

## Filename Substitution

After parameter substitution (and command substitution) is performed on the command line, the shell looks for the special characters `*`, `?`, and `[`. If they're not quoted, the shell searches the current directory, or another directory if preceded by a `/`, and substitutes the names of all files that match (these names are first alphabetized by the shell). If no match is found, the characters remain untouched.

Note that filenames beginning with a `.` must be explicitly matched (so `echo *` won't display your hidden files; `echo .*` will).

The filename substitution characters are summarized in [Table A.6](#).

Table A.6. Filename Substitution Characters

Character(s)	Meaning
<code>?</code>	Matches any single character.
<code>*</code>	Matches zero or more characters.
<code>[ chars ]</code>	Matches any single character in <i>chars</i> ; the format $C_1$ - $C_2$ can be used to match any character in the range $C_1$ through $C_2$ inclusive (for example, <code>[A-Z]</code> matches any uppercase letter).
<code>[ ! chars ]</code>	Matches any single character <i>not</i> in <i>chars</i> ; a range of characters may be specified previously.

## I/O Redirection

When scanning the command line, the shell looks for the special redirection characters `<` and `>`. If found, they are processed and removed (with any associated arguments) from the command line. [Table A.7](#) summarizes the different types of I/O redirection that the shell supports.

Table A.7. I/O Redirection

Construct	Meaning
<code>&lt; file</code>	Redirect standard input from <i>file</i> .
<code>&gt; file</code>	Redirect standard output to <i>file</i> , <i>file</i> is created if it doesn't exist and zeroed if it does.
<code>&gt;  file</code>	Redirect standard output to <i>file</i> , <i>file</i> is created if it doesn't exist and zeroed if it does; the <code>noclobber</code> ( <code>-C</code> ) option to <code>set</code> is ignored.
<code>&gt;&gt; file</code>	Like <code>&gt;</code> , only output is appended to <i>file</i> if it already exists.
<code>&lt;&lt; word</code>	Redirect standard input from lines that follow up until a line containing just <i>word</i> , parameter substitution occurs on the lines, and back-quoted commands are executed and the backslash character interpreted; if any character in <i>word</i> is quoted, none of this processing occurs and the lines are passed through unaltered; if <i>word</i> is preceded by a <code>-</code> , leading tabs on the lines are removed.
<code>&lt;&amp; digit</code>	Standard input is redirected from the file associated with file descriptor <i>digit</i> .
<code>&gt;&amp; digit</code>	Standard output is redirected to the file associated with file descriptor <i>digit</i> .
<code>&lt;&amp;-</code>	Standard input is closed.
<code>&gt;&amp;-</code>	Standard output is closed.
<code>&lt;&gt; file</code>	Open <i>file</i> for both reading and writing.

Note that filename substitution is not performed on *file*. Any of the constructs listed in the first column of the table may be preceded by a file descriptor number to have the same effect on the file associated with that file descriptor.

The file descriptor 0 is associated with standard input, 1 with standard output, and 2 with standard error.

## Exported Variables and Subshell Execution

Commands other than the shell's built-in commands are normally executed in a "new" shell, called a *subshell*. Subshells cannot change the values of variables in the parent shell, and they can only access variables from the parent shell that were *exported* to them—either implicitly or explicitly—by the parent. If the subshell changes the value of one of these variables and wants to have its own subshells know about it, it must explicitly export the variable before executing the subshell.

When the subshell finishes execution, any variables that it may have set are inaccessible by the parent.

### The `(...)` Construct

If one or more commands are placed inside parentheses, those commands will be executed in a subshell.

### The `{ ...; }` Construct

If one or more commands are placed inside curly braces, those commands will be executed by the *current* shell.

With this construct and the `(...)` construct, I/O can be redirected and piped into and out of the set of enclosed commands, and the set can be sent to the background for execution by placing an `&` at the end. For example,

```
(prog1; prog2; prog3) 2>errors &
```

submits the three listed programs to the background for execution, with standard error from all three programs redirected to the file `errors`.

## More on Shell Variables

A shell variable can be placed into the environment of a command by preceding the command name with the assignment to the parameter on the command line, as in

```
PHONEBOOK=$HOME/misc/phone rolo
```

Here the variable `PHONEBOOK` will be assigned the indicated value and then placed in `rolo`'s environment. The environment of the current shell remains unchanged, as if

```
(PHONEBOOK=$HOME/misc/phone; export PHONE BOOK; rolo)
```

had been executed instead.

**Team LiB**

[◀ PREVIOUS](#)

[NEXT ▶](#)



# Functions

Functions take the following form:

```
name () compound-command
```

where *compound-command* is a set of commands enclosed in (...), {...} or can be a `for`, `case`, `until`, or `while` command. Most often, the function definition takes this form:

```
name () { command, command, ... command, }
```

where *name* is the name of the function defined to the *current* shell (functions can't be exported). The function definition can span as many lines as necessary. A `return` command can be executed to cause execution of the function to be terminated without also terminating the shell (see [the return command](#) description).

For example,

```
nf () { ls | wc -l; }
```

defines a function called `nf` to count the number of files in your current directory.

# Job Control

## Shell Jobs

Every command sequence run in the background is assigned a job number, starting at one. The lowest available number not in use is assigned. A job may be referred to by a *job\_id*, which is a % followed by the job number, %+ , %- , %%, % followed by the first few letters of the pipeline, or %? *string*. The following built-in commands may be given a *job\_id* as an argument: `kill`, `fg`, `bg`, and `wait`. The special conventions %+ and %- refer to the current and previous jobs, respectively; %% also refers to the current job. The current job is the most recent job placed in the background or the job running in the foreground. The previous job is the previous current job. The convention %*string* refers to the job whose name begins with *string*. %?*string* refers to the job whose name contains *string*. The `jobs` command may be used to list the status of all currently running jobs.

If the `monitor` option of the `set` command is turned on, the shell prints a message when each job finishes. If you still have jobs when you try to exit the shell, a message is printed to alert you of this. If you immediately try to exit again, the shell exits. The monitor option is enabled by default for interactive shells.

## Stopping Jobs

If the shell is running on a system with job control, and the `monitor` option of the `set` command is turned on, jobs that are running in the foreground may be placed in the background and vice versa. Normally, `Ctrl+Z` stops the current job. The `bg` command puts a stopped job in the background. The `fg` command brings a background or stopped job to the foreground.

Whenever a job in the background attempts to read from the terminal, it is stopped until it is brought to the foreground. Output from background jobs normally comes to the terminal. If `stty tostop` is executed, output from background jobs is disabled, and a job writing to the terminal is stopped until it is brought to the foreground. When the shell exits, all stopped jobs are killed.

## Command Summary

This section summarizes the shell's built-in commands. Actually, some of these commands (such as `echo` and `test`) may not be built in to the shell but must be provided as a utility by a POSIX-compliant system. They are built in to Bash and the Korn shell and are so often used in shell scripts that we decided to list them here anyway.

The following commands are organized alphabetically for easy reference.

### The `:` Command

*General Format:* `:`

This is essentially a *null* command. It is frequently used to satisfy the requirement that a command appear.

*Example*

```
if who | grep jack > /dev/null
then
    :
else
    echo "jack's not logged in"
fi
```

The `:` command returns an exit status of zero.

### The `.` Command

*General Format:* `.` *file*

The "dot" command causes the indicated file to be read and executed by the shell, just as if the lines from the file were typed at that point. Note that *file* does not have to be executable, only readable. Also, the shell uses the `PATH` variable to find *file*.

*Example*

```
. progdefs           Execute commands in progdefs
```

The preceding command causes the shell to search the current `PATH` for the file `progdefs`. When it finds it, it reads and executes the commands from the file.

Note that because *file* is not executed by a subshell, variables set and/or changed within *file* remain in effect after execution of the commands in *file* is complete.

## The `alias` Command

*General Format:* `alias name=string [name=string...]`

The `alias` command assigns *string* to the alias *name*. Whenever *name* is used as a command, the shell substitutes *string*, performing command-line substitution after *string* is in place.

*Examples*

```
alias ll='ls -l'
```

```
alias dir='basename $(pwd)'
```

If an alias ends with a blank, the word following the alias is also checked to see whether it's an alias.

The format

```
alias name
```

causes the alias for *name* to be printed out.

`alias` with no arguments lists all aliases.

`alias` returns an exit status of zero unless a *name* is given (as in `alias name`) for which no alias has been defined.

## The `bg` Command

*General Format:* `bg job_id`

If job control is enabled, the job identified by *job\_id* is put into the background. If no argument is given, the most recently suspended job is put into the background.

*Example*

```
bg %2
```

## The `break` Command

*General Format:* `break`

Execution of this command causes execution of the innermost `for`, `while`, or `until` loop to be immediately terminated. Execution continues with the commands that immediately follow the loop.

If the format

```
break n
```

is used, where *n* is an integer greater than or equal to 1, execution of the *n* innermost loops is automatically terminated.

## The `case` Command

*General Format:*

```
case value in
    pat1) command
        command
        ...
        command;;
    pat2) command
        command
```

```

    ...
    command;;

    ...

    patn) command

    command

    ...

    command;;

```

esac

The word *value* is successively compared against *pat<sub>1</sub>*, *pat<sub>2</sub>*, ..., *pat<sub>n</sub>*, until a match is found. The commands that appear immediately after the matching pattern are then executed until a double semicolon (;;) is encountered. At that point, execution of the `case` is terminated.

If no pattern matches *value*, none of the commands inside the case are executed. The pattern `*` matches *anything* and is often used as the last pattern in a `case` as the "catchall" case.

The shell metacharacters `*` (match zero or more characters), `?` (match any single character), and `[...]` (match any single character enclosed between the brackets) can be used in patterns. The character `|` can be used to specify a logical ORing of two patterns, as in

```
pat1 | pat2
```

which means to match either *pat<sub>1</sub>* or *pat<sub>2</sub>*.

*Examples*

```

case $1 in
    -l) lopt=TRUE;;
    -w) wopt=TRUE;;
    -c) copt=TRUE;;
    *) echo "Unknown option";;
esac

```

```
case $choice in
```

```
[1-9]) valid=TRUE;;  
    *) echo "Please choose a number from 1-9";;  
esac
```

## The `cd` Command

*General Format:* `cd directory`

Execution of this command causes the shell to make *directory* the current directory. If *directory* is omitted, the shell makes the directory specified in the `HOME` variable the current directory.

If the shell variable `CDPATH` is null, *directory* must be a full directory path (for example, `/users/steve/documents`) or relative to the current directory (for example, `documents`, `../pat`).

If `CDPATH` is non-null and *directory* is not a full path, the shell searches the colon-delimited directory list in `CDPATH` for a directory containing *directory*.

*Examples*

```
$ cd documents/memos      Change to documents/memos directory
```

```
$ cd                      Change to HOME directory
```

An argument of `-` causes the shell to make the previous directory the current directory. The pathname of the new current directory is printed out.

*Examples*

```
$ pwd  
/usr/lib/uucp  
$ cd /  
$ cd -  
/usr/lib/uucp  
$
```

The `cd` command sets the shell variable `PWD` to the new current directory, and `OLDPWD` to the previous directory.

## The `continue` command

*General Format:* `continue`

Execution of this command from within a `for`, `while`, or `until` loop causes any commands that follow the `continue` to be skipped. Execution of the loop then continues as normal.

If the format

```
continue n
```

is used, the commands within the `n` innermost loops are skipped. Execution of the loops then continue as normal.

## The `echo` Command

*General Format:* `echo args`

This command causes `args` to be written to standard output. Each word from `args` is delimited by a blank space. A newline character is written at the end. If `args` is omitted, the effect is to simply skip a line.

Certain backslashed characters have a special meaning to `echo` as shown in [Table A.8](#).

Table A.8. `echo` Escape Characters

Character	Prints
<code>\a</code>	Alert
<code>\b</code>	Backspace
<code>\c</code>	The line without a terminating newline
<code>\f</code>	Formfeed
<code>\n</code>	Newline
<code>\r</code>	Carriage return



Character Prints

<code>\t</code>	Tab character
<code>\v</code>	Vertical tab character
<code>\\</code>	Backslash character
<code>\0 <i>mmm</i></code>	The character whose ASCII value is <i>mmm</i> , where <i>mmm</i> is a one- to three-digit octal number that starts with a zero

Remember to quote these characters so that the `echo` command interprets them and not the shell.

*Examples*

```
$ echo * List all files in the current directory
```

```
bin docs mail mise src
```

```
$ echo Skip a line
```

```
$ echo 'X\tY' Print X and Y, separated by a tab
```

```
X      Y
```

```
$ echo "\n\nSales Report" Skip two lines before displaying Sales Report
```

```
Sales Report
```

```
$ echo "Wake up!!\a" Print message and beep terminal
```

```
Wake up!!
```

```
$
```

## The `eval` Command

*General Format:* `eval args`

Execution of this command causes the shell to evaluate *args* and then execute the results. This is useful for causing the shell to effectively "double-scan" a command line.

*Example*

```
$ x='abc def'

$ y='$x'           Assign $x to y

$ echo $y

$x

$ eval echo $y

abc def

$
```

## The `exec` Command

*General Format:* `exec command args`

When the shell executes the `exec` command, it initiates execution of the specified *command* with the indicated arguments. Unlike other commands executed as a new process, *command* replaces the current process (that is, no new process is created). After *command* starts execution, there is no return to the program that initiated the `exec`.

If just I/O redirection is specified, the input and/or output for the shell is accordingly redirected.

*Examples*

```
exec /bin/sh           Replace current process with sh

exec < datafile        Reassign standard input to datafile
```

## The `exit` Command

*General Format:* `exit n`

Execution of `exit` causes the current shell program to be immediately terminated. The exit status of the program is the value of the integer *n*, if supplied. If *n* is not supplied, the exit status is that of the last command executed prior to the `exit`.

An exit status of zero is used by convention to indicate "success," and nonzero to indicate "failure" (such as an error condition). This convention is used by the shell in evaluation of conditions for `if`, `while`, and `until` commands, and with the `&&` and `||` constructs.

## *Examples*

```
who | grep $user > /dev/null
```

```
exit Exit with status of last grep
```

```
exit 1 Exit with status of 1
```

```
if finduser If finduser returns an exit status of zero then...
```

```
then
```

```
...
```

```
fi
```

Note that executing `exit` from a login shell has the effect of logging you off.

## **The `export` Command**

*General Format: `export variables`*

The `export` command tells the shell that the indicated variables are to be marked as exported; that is, their values are to be passed down to subshells.

## *Examples*

```
export PATH PS1
```

```
export dbhome x1 y1 date
```

Variables may be set when exported using the form

```
export variable=value...
```

So lines such as

```
PATH=$PATH:$HOME/bin; export PATH
CDPATH=.:$HOME:/usr/spool/uucppublic; export CDPATH
```

can be rewritten as

```
export PATH=$PATH:$HOME/bin CDPATH=.:$HOME:/usr/spool/uucppublic
```

The output of `export` with a `-p` argument is a list of the exported variables and their values in the form

```
export variable=value
```

or

```
export variable
```

if *variable* has been exported but not yet set.

## The `false` Command

*General Format:* `false`

The `false` command simply returns a nonzero exit status.

## The `fc` Command

*General Format:* `fc -e editor -lnr first last`

`fc -s old=new first`

The `fc` command is used to edit commands in the command history. A range of commands is specified from *first* to *last*, where *first* and *last* can be either command numbers or strings; a negative number is taken as an offset from the current command number; a string specifies the most recently entered command beginning with that string. The commands are read into the editor and executed upon exit from the editor. If no editor is specified, the value of the shell variable `FCEDIT` is used; if `FCEDIT` is not set, `ed` is used.

The `-l` option lists the commands from *first* to *last* (that is, an editor is not invoked). If the `-n` option is also selected, these commands are not preceded by command numbers.

The `-r` option to `fc` reverses the order of the commands.

If *last* is not specified, it defaults to *first*. If *first* is also not specified, it defaults to the previous command for editing and to -16 for listing.

The `-s` option causes the selected command to be executed without editing it first. The format

```
fc -s old=new first
```

causes the command *first* to be re-executed after the string *old* in the command is replaced with *new*. If *first* isn't specified, the previous command is used, and if *old=new* isn't specified, the command is not changed.

### *Examples*

```
fc -l                               List the last 16 commands
```

```
fc -e vi sed                         Read the last sed command into vi
```

```
fc 100 110                           Read commands 100 to 110 into $FCEDIT
```

```
fc -s                                 Re-execute the previous command
```

```
fc -s abc=def 104                     Re-execute command 104, replacing abc with def
```

## The `fg` Command

*General Format:* `fg job_id`

If job control is enabled, the job specified by *job\_id* is brought to the foreground. If no argument is given, the most recently suspended job, or the job last sent to the background is brought to the foreground.

*Example*

```
fg %2
```

## The `for` Command

*General Format:*

```
for var in word1 word2 ... wordn
do
    command
    command
    ...
done
```

Execution of this command causes the commands enclosed between the `do` and `done` to be executed as many times as there are words listed after the `in`.

The first time through the loop, the first word—*word<sub>1</sub>*—is assigned to the variable *var* and the commands between the `do` and `done` executed. The second time through the loop, the second word listed—*word<sub>2</sub>*—is assigned to *var* and the commands in the loop executed again. This process continues until the last variable in the list—*word<sub>n</sub>*—is assigned to *var* and the commands between the `do` and `done` executed. At that point, execution of the `for` loop is terminated. Execution then continues with the command that immediately follows the `done`.

The special format

```
for var
do
```

```
...
```

```
done
```

indicates that the positional parameters "\$1", "\$2", ... are to be used in the list and is equivalent to

```
for var in "$@"
```

```
do
```

```
...
```

```
done
```

*Example*

```
# nroff all of the files in the current directory
```

```
for file in *
```

```
do
```

```
    nroff -Tlp $file | lp
```

```
done
```

## The `getopts` Command

*General Format:* `getopts options var`

This command processes command-line arguments. *options* is a list of valid single letter options. If any letter in *options* is followed by a `:`, that option takes a following argument on the command line, which must be separated from the option by at least one whitespace character.

Each time `getopts` is called, it processes the next command-line argument. If a valid option is found, `getopts` stores the matching option letter inside the specified variable *var* and returns a zero exit status.

If an invalid option is specified (that is, one not listed in *options*), `getopts` stores a `?` inside *var* and returns with a zero exit status. It also writes an error message to standard error.

If an option takes a following argument, `getopts` stores the matching option letter inside `var` and stores the following command-line argument inside the special variable `OPTARG`. If no arguments are left on the command line, `getopts` stores a `?` inside `var` and writes an error message to standard error.

If no more options remain on the command line (that is, if the next command-line argument does not begin with a `-`), `getopts` returns a nonzero exit status.

The special variable `OPTIND` is also used by `getopts`. It is initially set to 1 and is adjusted each time `getopts` returns to indicate the number of the next command-line argument to be processed.

The argument `--` can be placed on the command line to specify the end of the command-line arguments.

`getopts` supports stacked arguments, as in

```
repx -iaiu
```

which is equivalent to

```
repx -i -a -u
```

Options that take following arguments may not be stacked.

If the format

```
getopts options var args
```

is used, `getopts` parses the arguments specified by `args` rather than the command-line arguments.

*Example*

```
usage="Usage: foo [-r] [-O outfile] infile"
```

```
while getopts ro: opt
```

```
do
```



```

    case "$opt"
    in
        r) rflag=1;;
        O) oflag=1
           ofile=$OPTARG;;
        \?) echo "$usage"
           exit 1;;
    esac
done

if [ $OPTIND -gt $# ]
then
    echo "Needs input file!"
    echo "$usage"
    exit 2
fi

shift $((OPTIND - 1))
ifile=$1
...

```

## The `hash` Command

*General Format:* `hash commands`

This command tells the shell to look for the specified commands and to remember what directories they are located in. If *commands* is not specified, a list of the hashed commands is displayed.

If the format

```
hash -r
```

is used, the shell removes all commands from its hash list. Next time any command is executed, the shell uses its normal search methods to find the command.

### *Examples*

```
hash rolo whoq           Add rolo and whoq to hash list
```

```
hash                    Print hash list
```

```
hash -r                 Remove hash list
```

## The `if` Command

### *General Format:*

```
if commandt  
then  
    command  
    command  
    ...  
fi
```

*command*<sub>t</sub> is executed and its exit status tested. If it is zero, the commands that follow up to the `fi` are executed. Otherwise, the commands that follow up to the `fi` are skipped.

### *Example*

```
if grep $sys sysnames > /dev/null
then
    echo "$sys is a valid system name"
fi
```

If the `grep` returns an exit status of zero (which it will if it finds `$sys` in the file `sysnames`), the `echo` command is executed; otherwise it is skipped.

The built-in command `test` is often used as the command following the `if`.

*Example*

```
if [ $# -eq 0 ]
then
    echo "Usage: $0 [-l] file ..."
    exit 1
fi
```

An `else` clause can be added to the `if` to be executed if the command returns a nonzero exit status. In this case, the general format of the `if` becomes

```
if commandt
then
    command
    command
    ...
else
    command
    command
```

...

fi

If *command<sub>i</sub>* returns an exit status of zero, the commands that follow up to the **else** are executed, and the commands between the **else** and the **fi** are skipped. Otherwise, *command<sub>i</sub>* returns a nonzero exit status and the commands between the **then** and the **else** are skipped, and the commands between the **else** and the **fi** are executed.

*Example*

```
if [ -z "$line" ]
then
    echo "I couldn't find $name"
else
    echo "$line"
fi
```

In the preceding example, if **line** has zero length, the **echo** command that displays the message **I couldn't find \$name** is executed; otherwise, the **echo** command that displays the value of **line** is executed.

A final format of the **if** command is useful when more than a two-way decision has to be made. Its general format is

```
if command1
then
    command
    command
    ...
elif command2
then
```

```
    command

    command

    ...
elif commandn
then
    command

    command

    ...
else
    command

    command

    ...
fi
```

*command*<sub>*i*</sub>, *command*<sub>*2*</sub>, ..., *command*<sub>*n*</sub> are evaluated in order until one of the commands returns an exit status of zero, at which point the commands that immediately follow the `then` (up to another `elif`, `else`, or `fi`) are executed. If none of the commands returns an exit status of zero, the commands listed after the `else` (if present) are executed.

#### *Example*

```
if [ "$choice" = a ]
then
    add $*
elif [ "$choice" = d ]
then
    delete $*
elif [ "$choice" = l ]
then
```

```
        list
else
    echo "Bad choice!"
    error=TRUE
fi
```

## The `jobs` Command

*General Format:* `jobs`

The list of active jobs is printed. If the `-l` option is specified, detailed information about each job, including its process id, is listed as well. If the `-p` option is specified, only process ids are listed.

If an optional `job_id` is supplied to the `jobs` command, just information about that job is listed.

*Example*

```
$ sleep 100 &

[1] 1104

$ jobs

[1] + Running          sleep 100 &

$
```

## The `kill` Command

*General Format:* `kill -signal job`

The `kill` command sends the signal `signal` to the specified process, where `job` is a process id number or `job_id`, and `signal` is a number or one of the signal names specified in `<signal.h>` (see the description of `trap` later in the chapter). `kill -l` lists these names. A signal number supplied with the `-l` option lists the corresponding signal name. A process id used with the `-l` option lists the name of the signal that terminated the specified process (if it was terminated by a signal).

The `-s` option can also be used when a signal name is supplied, in which case the dash before the name is not used (see the following example).

If *signal* isn't specified, `TERM` is used.

### *Examples*

```
kill -9 1234
```

```
kill -HUP %2
```

```
kill -s TERM %2
```

```
kill %1
```

Note that more than one process id can be supplied to the `kill` command on the command line.

## The `newgrp` Command

*General Format:* `newgrp group`

This command changes your real group id (GID) to *group*. If no argument is specified, it changes you back to your default group.

### *Examples*

```
newgrp shbook          Change to group shbook
```

```
newgrp                 Change back to default group
```

If a password is associated with the new group, and you are not listed as a member of the group, you will be prompted to enter it.

`newgrp -l` changes you back to your login group.

## The `pwd` Command

*General Format:* `pwd`

This command tells the shell to print your working directory, which is written to standard output.

### *Examples*

```
$ pwd
/users/steve/documents/memos
$ cd
$ pwd
/users/steve
$
```

## The `read` Command

*General Format:* `read vars`

This command causes the shell to read a line from standard input and assign successive whitespace-delimited words from the line to the variables *vars*. If fewer variables are listed than there are words on the line, the excess words are stored in the last variable.

Specifying just one variable has the effect of reading and assigning an entire line to the variable.

The exit status of `read` is zero unless an end-of-file condition is encountered.

*Examples*

```
$ read hours mins
10 19
$ echo "$hours:$mins"
10:19
```

```
$ read num rest
39 East 12th Street, New York City 10003
$ echo "$num\n$rest"
39
East 12th Street, New York City 10003
```



```

$ read line
      Here    is an entire    line \r
$ echo "$line"
Here    is an entire    line r
$

```

Note in the final example that any leading whitespace characters get "eaten" by the shell when read. You can change `IFS` if this poses a problem.

Also note that backslash characters get interpreted by the shell when you read the line, and any that make it through (double backslashes will get through as a single backslash) get interpreted by `echo` if you display the value of the variable.

A `-r` option to `read` says to not treat a `\` character at the end of a line as line continuation.

## The `readonly` Command

*General Format:* `readonly vars`

This command tells the shell that the listed variables cannot be assigned values. These variables may be optionally assigned values on the `readonly` command line. If you subsequently try to assign a value to a `readonly` variable, the shell issues an error message.

`readonly` variables are useful for ensuring that you don't accidentally overwrite the value of a variable. They're also good for ensuring that other people using a shell program can't change the values of particular variables (for example, their `HOME` directory or their `PATH`). The `readonly` attribute is not passed down to subshells.

`readonly` with a `-p` option prints a list of your `readonly` variables.

*Example*

```

$ readonly DB=/users/steve/database    Assign value to DB and make it readonly
$ DB=foo                                Try to assign it a value
sh: DB: is read-only                    Error message from the shell
$ echo $DB                               But can still access its value
/users/steve/database

```

\$

## The `return` Command

*General Format:* `return n`

This command causes the shell to stop execution of the current function and immediately return to the caller with an exit status of *n*. If *n* is omitted, the exit status returned is that of the command executed immediately prior to the `return`.

## The `set` Command

*General Format:* `set options args`

This command is used to turn on or off options as specified by *options*. It is also used to set positional parameters, as specified by *args*.

Each single letter option in *options* is enabled if the option is preceded by a minus sign (-), or disabled if preceded by a plus sign (+). Options can be grouped, as in

```
set -fx
```

which enables the `f` and `x` options.

[Table A.9](#) summarizes the options that can be selected.

Table A.9. `set` Options

Meaning	Option
--	Don't treat subsequent <i>args</i> preceded by a - as options. If there are no arguments, the positional parameters are unset.
-a	Automatically export all variables that are subsequently defined or modified.
-b	If supported by the implementation, cause the shell to notify you when background jobs finish.
-C	Don't allow output redirection to overwrite existing files. <code>&gt; </code> can still be used to force individual files to be overwritten even if this option is selected.
-e	Exit if any command that gets executed fails or has a nonzero exit status.

Option	Meaning
<code>-f</code>	Disable filename generation.
<code>-h</code>	Add commands inside functions to the hash list as they are defined, and not as they are executed.
<code>-m</code>	Turn on the job monitor.
<code>-n</code>	Read commands without executing them (useful for checking for balanced <code>do...done</code> s, and <code>if...fi</code> s).
<code>+o</code>	Write current option mode settings in command format.
<code>-o <i>m</i></code>	Turn on option mode <i>m</i> (see <a href="#">Table A.10</a> ).
<code>-u</code>	Issue an error if a variable is referenced without having been assigned a value or if a positional parameter is referenced without having been set.
<code>-v</code>	Print each shell command line as it is read.
<code>-x</code>	Print each command and its arguments as it is executed, preceded by a <code>+</code> .

Shell modes are turned on or off by using the `-o` and `+o` options, respectively, followed by an option name. These options are summarized in [Table A.10](#).

Table A.10. Shell Modes

Mode	Meaning
<code>allexport</code>	Same as <code>-a</code> .
<code>errexit</code>	Same as <code>-e</code> .
<code>ignoreeof</code>	The exit command must be used to leave the shell.
<code>monitor</code>	Same as <code>-m</code> .
<code>noclobber</code>	Same as <code>-C</code> .
<code>noexec</code>	Same as <code>-n</code> .
<code>noglob</code>	Same as <code>-f</code> .
<code>nolog</code>	Don't put function definitions in the history.
<code>nounset</code>	Same as <code>-u</code> .
<code>verbose</code>	Same as <code>-v</code> .
<code>vi</code>	The inline editor is set to <code>vi</code> .
<code>xtrace</code>	Same as <code>-x</code> .

The command `set -o` without any following options has the effect of listing all shell modes and their settings.

The shell variable `$-` contains the current options setting.

Each word listed in *args* is set to the positional parameters `$1`, `$2`, `...`, respectively. If the first word might start with a minus sign, it's safer to specify the `--` option to `set` to avoid interpretation of that value.

If *args* is supplied, the variable `$#` will be set to the number of parameters assigned after execution of the command.

### *Examples*

```
set -vx Print all command lines as they are read,  
and each command and its arguments as  
it is executed
```

```
set "$name" "$address" "$phone" Set $1 to $name, $2 to $address, and $3 to  
$phone
```

```
set -- -1 Set $1 to -1
```

```
set -o vi Turn on vi mode
```

```
set +o verbose -o noglob Turn verbose mode off, noglob on
```

## The `shift` Command

*General Format:* `shift`

This command causes the positional parameters `$1`, `$2`, `...`, `$n` to be "shifted left" one place. That is, `$2` is assigned to `$1`, `$3` to `$2`, `...`, and `$n` to `$n-1`. `$#` is adjusted accordingly.

If the format

```
shift n
```

is used instead, the shift is to the left *n* places.

*Examples*

```
$ set a b c d
$ echo "$#\n$*"
4
a b c d
$ shift
$ echo "$#\n$*"
3
b c d
$ shift 2
$ echo "$#\n$*"
1
d
$
```

## The `test` Command

*General Format:*

```
test condition
```

*or*

```
[ condition ]
```

The shell evaluates *condition* and if the result of the evaluation is *TRUE*, returns a zero exit status. If the result of the evaluation is *FALSE*, a nonzero exit status is returned. If the format [ *condition* ] is used, a space must appear immediately after the [ and before the ].

*condition* is composed of one or more operators as shown in [Table A.11](#). The `-a` operator has higher precedence than the `-o` operator. In any case, parentheses can be used to group subexpressions. Just remember that the parentheses are significant to the shell and so must be quoted. Operators and operands (including parentheses) must be delimited by one or more spaces so that `test` sees them as separate arguments.

`test` is often used to test conditions in an `if`, `while`, or `until` command.

#### *Examples*

```
# see if perms is executable
```

```
if test -x /etc/perms
```

```
then
```

```
    ...
```

```
fi
```

```
# see if it's a directory or a normal file that's readable
```

```
if [ -d $file -o \( -f $file -a -r $file \) ]
```

```
then
```

```
    ...
```

```
fi
```

Table A.11. `test` Operators

Operator	Returns TRUE (zero exit status) if
File Operators	

Operator	Returns TRUE (zero exit status) if
<code>-b file</code>	<i>file</i> is a block special file
<code>-c file</code>	<i>file</i> is a character special file
<code>-d file</code>	<i>file</i> is a directory
<code>-e file</code>	<i>file</i> exists
<code>-f file</code>	<i>file</i> is an ordinary file
<code>-g file</code>	<i>file</i> has its set group id (SGID) bit set
<code>-h file</code>	<i>file</i> is a symbolic link
<code>-k file</code>	<i>file</i> has its sticky bit set
<code>-L file</code>	<i>file</i> is a symbolic link
<code>-p file</code>	<i>file</i> is a named pipe
<code>-r file</code>	<i>file</i> is readable by the process
<code>-S file</code>	<i>file</i> is a socket
<code>-s file</code>	<i>file</i> has nonzero length
<code>-t fd</code>	<i>fd</i> is open file descriptor associated with a terminal (1 is default)
<code>-u file</code>	<i>file</i> has its set user id (SUID) bit set
<code>-w file</code>	<i>file</i> is writable by the process
<code>-x file</code>	<i>file</i> is executable

#### String Operators

<i>string</i>	<i>string</i> is not null
<code>-n string</code>	<i>string</i> is not null (and <i>string</i> must be seen by <code>test</code> )
<code>-z string</code>	<i>string</i> is null (and <i>string</i> must be seen by <code>test</code> )
<code>string<sub>1</sub> = string<sub>2</sub></code>	<i>string<sub>1</sub></i> is identical to <i>string<sub>2</sub></i>
<code>string<sub>1</sub> != string<sub>2</sub></code>	<i>string<sub>1</sub></i> is <i>not</i> identical to <i>string<sub>2</sub></i>

#### Integer Comparison Operators

<code>int<sub>1</sub> -eq int<sub>2</sub></code>	<i>int<sub>1</sub></i> is equal to <i>int<sub>2</sub></i>
<code>int<sub>1</sub> -ge int<sub>2</sub></code>	<i>int<sub>1</sub></i> is greater than or equal to <i>int<sub>2</sub></i>
<code>int<sub>1</sub> -gt int<sub>2</sub></code>	<i>int<sub>1</sub></i> is greater than <i>int<sub>2</sub></i>
<code>int<sub>1</sub> -le int<sub>2</sub></code>	<i>int<sub>1</sub></i> is less than or equal to <i>int<sub>2</sub></i>
<code>int<sub>1</sub> -lt int<sub>2</sub></code>	<i>int<sub>1</sub></i> is less than <i>int<sub>2</sub></i>
<code>int<sub>1</sub> -ne int<sub>2</sub></code>	<i>int<sub>1</sub></i> is not equal to <i>int<sub>2</sub></i>

#### Boolean Operators

Operator	Returns TRUE (zero exit status) if
<code>! expr</code>	<code>expr</code> is <i>FALSE</i> ; otherwise, returns <i>TRUE</i>
<code>expr<sub>1</sub>-a expr<sub>2</sub></code>	<code>expr<sub>1</sub></code> is <i>TRUE</i> , and <code>expr<sub>2</sub></code> is <i>TRUE</i>
<code>expr<sub>1</sub>-o expr<sub>2</sub></code>	<code>expr<sub>1</sub></code> is <i>TRUE</i> , or <code>expr<sub>2</sub></code> is <i>TRUE</i>

## The `times` Command

*General Format:* `times`

Execution of this command causes the shell to write to standard output the total amount of time that has been used by the shell and by all its child processes. For each, two numbers are listed: first the accumulated user time and then the accumulated system time.

Note that `times` does not report the time used by built-in commands.

*Example*

```
$ times          Print time used by processes
1m5s 2m9s       1 min., 5 secs. user time, 2 mins., 9 secs. system time
8m22.23s 6m22.01s Time used by child processes
$
```

## The `trap` Command

*General Format:* `trap commands signals`

This command tells the shell to execute *commands* whenever it receives one of the signals listed in *signals*. The listed signals can be specified by name or number.

`trap` with no arguments prints a list of the current trap assignments.

If the first argument is the null string, as in

```
trap "" signals
```

the signals in *signals* are ignored when received by the shell.

If the format



```
trap signals
```

is used, processing of each signal listed in *signals* is reset to the default action.

#### Examples

```
trap "echo hangup >> $ERRFILE; exit" 2      Log message and exit on hangup
```

```
trap "rm $TMPFILE; exit" 1 2 15           remove $TMPFILE on signals 1, 2, or 15
```

```
trap "" 2                                  Ignore interrupts
```

```
trap 2                                     Reset default processing of interrupts
```

[Table A.12](#) lists values that can be specified in the signal list.

Table A.12. Signal Numbers and Names for **trap**

Signal #	Signal Name	Generated for
0	EXIT	Exit from the shell
1	HUP	Hangup
2	INT	Interrupt (for example, Delete key, <i>Ctrl+c</i> )
3	QUIT	Quit
6	ABRT	Abort
9	KILL	Kill
14	ALRM	Alarm timeout
15	TERM	Software termination signal (sent by <b>kill</b> by default)

The shell scans *commands* when the **trap** command is encountered and again when one of the listed signals is received. This means, for example, that when the shell encounters the command

```
trap "echo $count lines processed >> $LOGFILE; exit" HUP INT TERM
```

it substitutes the value of `count` at that point, and *not when one of the signals is received*. You can get the value of `count` substituted when one of the signals is received if you instead enclose the commands in single quotes:

```
trap 'echo $count lines processed >> $LOGFILE; exit' HUP INT TERM
```

## The `true` Command

*General Format:* `true`

This command returns a zero exit status.

## The `type` Command

*General Format:* `type commands`

This command prints information about the indicated commands.

*Examples*

```
$ type troff echo
troff is /usr/bin/troff
echo is a shell builtin
$
```

## The `umask` Command

*General Format:* `umask mask`

`umask` sets the default file creation mask to `mask`. Files that are subsequently created are ANDed with this mask to determine the mode of the file.

`umask` with no arguments prints the current mask. The `-S` option says to produce symbolic output.

*Examples*

```
$ umask                                Print current mask
0002                                       No write to others
$ umask 022                             No write to group either
$
```

## The `unalias` Command

*General Format:* `unalias names`

The alias's *names* are removed from the alias list. The `-a` option says to remove all aliases.

## The `unset` Command

*General Format:* `unset names`

This causes the shell to erase definitions of the variables or functions listed in *names*. Read-only variables cannot be unset. The `-v` option to `unset` specifies that a variable name follows, whereas the `-f` option specifies a function name. If neither option is used, it is assumed that variable name(s) follow.

*Example*

```
unset dblist files                       Remove definitions of variables dblist and files
```

## The `until` Command

*General Format:*

```
until commandt
do
```

```
command
```

```
command
```

```
...
```

```
done
```

*command<sub>i</sub>* is executed and its exit status tested. If it is nonzero, the commands enclosed between the **do** and **done** are executed. Then *command<sub>i</sub>* is executed again and its status tested. If it is nonzero, the commands between the **do** and **done** are once again executed. Execution of *command<sub>i</sub>* and subsequent execution of the commands between the **do** and **done** continues until *command<sub>i</sub>* returns a zero exit status, at which point the loop is terminated. Execution then continues with the command that follows the **done**.

Note that because *command<sub>i</sub>* gets evaluated immediately on entry into the loop, the commands between the **do** and **done** may never be executed if it returns a zero exit status the first time.

*Example*

```
# sleep for 60 seconds until jack logs on
```

```
until who | grep jack > /dev/null
```

```
do
```

```
    sleep 60
```

```
done
```

```
echo jack has logged on
```

The preceding loop continues until the **grep** returns a zero exit status (that is, finds **jack** in **who**'s output). At that point, the loop is terminated, and the **echo** command that follows is executed.

## The **wait** Command

*General Format:* **wait** *job*

This command causes the shell to suspend its execution until the process identified as *job* finishes executing. *Job* can be a process id number or a *job\_id*. If *job* is not supplied, the shell waits for all child processes to finish executing. If more than one process id is listed, **wait** will wait for them all to complete.

`wait` is useful for waiting for processes to finish that have been sent to the background for execution.

*Example*

```
sort large_file > sorted_file &      sort in the background
. . .                                Continue processing
wait                                  Now wait for sort to finish
plotdata sorted_file
```

The variable `#!` can be used to obtain the process id number of the last process sent to the background.

## The `while` Command

*General Format:*

```
while commandt
do
    command
    command
    . . .
done
```

*command*<sub>t</sub> is executed and its exit status tested. If it is zero, the commands enclosed between the `do` and `done` are executed. Then *command*<sub>t</sub> is executed again and its status tested. If it is zero, the commands between the `do` and `done` are once again executed. Execution of *command*<sub>t</sub> and subsequent execution of the commands between the `do` and `done` continues until *command*<sub>t</sub> returns a nonzero exit status, at which point the loop is terminated. Execution then continues with the command that follows the `done`.

Note that because *command*<sub>t</sub> gets evaluated immediately on entry into the loop, the commands between the `do` and `done` may never be executed if it returns a nonzero exit status the first time.

*Example*

```
# fill up the rest of the buffer with blank lines
```

```
while [ $lines -le $maxlines ]
```

```
do
```

```
    echo >> $BUFFER
```

```
    lines=$((lines + 1))
```

```
done
```

**Team LiB**

[← PREVIOUS](#)

[NEXT →](#)

# Appendix B. For More Information

IN THIS APPENDIX

- [Online Documentation](#)
- [Documentation on the Web](#)
- [Books](#)

Many sources of information on the Unix system are available; however, we have selectively listed some titles and Web sites here of particular value to shell programmers. All Web sites and URLs are valid as of the publication of this book, but as is often the case on the Internet, some may not be available by the time you read this.

There is one reference that you cannot do without. This is the Unix documentation for your particular system. It gives detailed descriptions on the syntax and various options for each of the commands.

## Online Documentation

If a printed version of your system's documentation isn't available, you can use the `man` command to get information (referred to as the "man pages" by Unix users) about any specific Unix command. The format is

`man command`

Some systems have an interactive documentation command called `info`. To invoke it, simply type `info`. After it starts up, just type `h` for a tutorial.

Note that some smaller systems may not have online documentation due to disk space limitations. However, almost all this information is also available on the Web and in printed form.



## Documentation on the Web

The authors of this book maintain the Web site at [www.kochan-wood.com](http://www.kochan-wood.com). You can download the `rolo` program; get answers to the exercises; and find out more about Unix, the C programming language, and shell programming there.

The best place on the Web for information on the POSIX standard is at [www.unix.org](http://www.unix.org). This site is maintained by The Open Group, an international consortium that worked with the IEEE to create the current POSIX specification. The complete specification is available on its Web site. You must register first to read it, but registration is free. The URL for accessing the documentation is [www.unix.org/online.html](http://www.unix.org/online.html). You can also purchase for download a printable copy of the Open Group Unix documentation at [www.opengroup.org/pubs/catalog/un.htm](http://www.opengroup.org/pubs/catalog/un.htm). (The standards publications are only available for download or on CD-ROM, although you may still be able to find some older, out-of-print hard-copy versions at [Amazon.com](http://Amazon.com).)

The Free Software Foundation maintains online documentation for a variety of Unix utilities, including Bash, at [www.fsf.org/manual](http://www.fsf.org/manual).

David Korn, the developer of the Korn shell, maintains [www.kornshell.com](http://www.kornshell.com). It contains documentation, downloads, information on books on the Korn shell, and links to information on other shells.

If you want to experiment with the Korn shell, or you're using a system that doesn't have a POSIX compliant shell, you can download the Korn shell executable for a variety of Unix systems for free from [www.research.att.com/sw/download/](http://www.research.att.com/sw/download/).

If you only have access to Microsoft Windows systems but still want to try your hand at shell programming, or you just want to get a taste of Unix, install the Cygwin package from [www.cygwin.com](http://www.cygwin.com). The base system includes Bash, and you can also download other shells such as `zsh`. The total feel of the system is remarkably like Unix, even though it's running on Windows. There's even an X Window System available to enhance the Unix look and feel. Best of all, the entire Cygwin package is free.

# Books

## O'Reilly & Associates

One of the best sources of books on Unix-related topics is O'Reilly and Associates ([www.ora.com](http://www.ora.com)). Their books cover a wide variety of subjects and are available from their Web site, from booksellers online, and in book stores. Their Web site also has many useful articles on Unix and Linux.

Two good references on Unix and Linux, respectively:

*Unix in a Nutshell: System V Edition*, 3rd Edition, A. Robbins, O'Reilly & Associates, 1999 (ISBN 1565924274).

*Linux in a Nutshell*, 3rd Edition, E. Siever, S. Spainhour, J. P. Hekman, and S. Figgins, O'Reilly & Associates, 2000 (ISBN 0596000251).

Four good books on Perl programming, from beginner to advanced:

*Learning Perl*, 3rd Edition, R. L. Schwartz and T. Phoenix, O'Reilly & Associates, 2001 (ISBN 0596001320).

*Perl in a Nutshell*, 2nd Edition, S. Spainhour, E. Siever, and N. Patwardhan, O'Reilly & Associates, 2002 (ISBN 0596002416).

*Programming Perl*, 3rd Edition, L. Wall, T. Christiansen, and J. Orwant, O'Reilly & Associates, 2000 (ISBN 0596000278).

*Advanced Perl Programming*, S. Srinivasan, O'Reilly & Associates, 1997 (ISBN 1565922204).

A good book covering both the POSIX standard versions of `awk` and `sed` as well as the GNU versions:

*Sed & Awk*, 2nd Edition, D. Dougherty and A. Robbins, O'Reilly & Associates, 1997 (ISBN 1565922255).

## Sams and Que

Learn the essentials of Unix shell programming from the ground up:

*Sams Teach Yourself Shell Programming in 24 Hours*, 2nd Edition, Sriranga Veeraraghaven, Sams Publishing, 2002 (ISBN 0672323583).

A good book for learning Unix and programming in C and Perl on a Unix system:

*Sams Teach Yourself Unix in 24 Hours*, 3rd Edition, Dave Taylor, Sams Publishing, 2001 (ISBN 0672321270).

This book offers a series of lectures written by several Unix experts who have years of experience to share with their audience:

*Unix Unleashed*, Robin Anderson and Andy Johnston, Sams Publishing, 2001 (ISBN 067232251X).

This book offers detailed information on a broad range of Red Hat Linux topics, from installation to multimedia:

*Red Hat Linux 8 Unleashed*, Billy Ball, Sams Publishing, 2002 (ISBN 067232458X).

Learn how to efficiently install Red Hat Linux 8 and then get the most out of your system:

*Sams Teach Yourself Red Hat Linux 8.0 in 24 Hours*, Aron Hsiao, Sams Publishing, 2003 (ISBN 067232475X).

This title offers a broad range of FreeBSD-related topics. It is detailed in its approach and offers information not found anywhere else:

*FreeBSD Unleashed*, Michael Urban and Brian Tiemann, Sams Publishing, 2001 (ISBN 0672322064).

Learn FreeBSD from the ground up. This book is the only beginning level tutorial that offers all the ins and outs of the FreeBSD operating system:

*Sams Teach Yourself FreeBSD in 24 Hours*, Michael Urban and Brian Tiemann, 2002 (ISBN 0672324245).

## Other Publishers

This is the set of standard documentation for System V, Release 4 produced by AT&T. Although thorough, this two-book set dates from the early 1990s:

*User's Reference Manual/System Administrator's Reference Manual*, Prentice Hall, 1992 (ISBN 0139513108).

The following book contains complete coverage of the Korn shell, and is coauthored by its creator:

*The New KornShell Command and Programming Language*, 2nd Edition, D. Korn and M. Borsky, Prentice Hall, 1995 (ISBN 0131827006).

An in-depth reference to the C shell:

*The Unix C Shell Field Guide*, G. Anderson and P. Anderson, Prentice Hall, 1986 (ISBN 013937468X).

A complete description of the `awk` language authored by its creators:

*The AWK Programming Language*, A. V. Aho, B. W. Kernighan, and P. J. Weinberger, Addison-Wesley, 1988 (ISBN 020107981X).

An advanced Unix programming book:

*The Unix Programming Environment*, B. W. Kernighan and R. Pike, Prentice Hall, 1984 (ISBN 013937681X).

An advanced Linux programming book:

*Advanced Linux Programming*, M. Mitchell, J. Oldham, and A. Samuel, New Riders Publishing, 2001 (ISBN 0735710430).

[Team LiB](#)

[← PREVIOUS](#)

[NEXT →](#)

Team LiB

← PREVIOUS

[\[SYMBOL\]](#) [\[A\]](#) [\[B\]](#) [\[C\]](#) [\[D\]](#) [\[E\]](#) [\[F\]](#) [\[G\]](#) [\[H\]](#) [\[I\]](#) [\[J\]](#) [\[K\]](#) [\[L\]](#) [\[M\]](#) [\[N\]](#) [\[O\]](#) [\[P\]](#) [\[Q\]](#) [\[R\]](#) [\[S\]](#) [\[T\]](#) [\[U\]](#) [\[V\]](#) [\[W\]](#) [\[X\]](#) [\[Y\]](#) [\[Z\]](#)

Team LiB

← PREVIOUS

[\[SYMBOL\]](#) [\[A\]](#) [\[B\]](#) [\[C\]](#) [\[D\]](#) [\[E\]](#) [\[F\]](#) [\[G\]](#) [\[H\]](#) [\[I\]](#) [\[J\]](#) [\[K\]](#) [\[L\]](#) [\[M\]](#) [\[N\]](#) [\[O\]](#) [\[P\]](#) [\[Q\]](#) [\[R\]](#) [\[S\]](#) [\[T\]](#) [\[U\]](#) [\[V\]](#) [\[W\]](#) [\[X\]](#) [\[Y\]](#) [\[Z\]](#)

[!\(logical negation\) operator](#) [2nd](#)  
[!= operator](#)  
[# \(pound sign\)](#) [2nd](#) [3rd](#) [4th](#) [5th](#)  
[# command \(vi\)](#)  
[#! construct](#)  
[\\$ \(dollar sign\)](#) [2nd](#) [3rd](#) [4th](#) [5th](#)  
[\\$ command \(vi\)](#) [2nd](#) [3rd](#)  
[\\$! variable](#) [2nd](#) [3rd](#)  
[\\$# variable](#) [2nd](#) [3rd](#) [4th](#)  
[\\$\\$ variable](#) [2nd](#)  
[\\$\(...\) construct](#) [2nd](#) [3rd](#) [4th](#) [5th](#) [6th](#) [7th](#) [8th](#) [9th](#)  
[\\$\\* variable](#) [2nd](#) [3rd](#) [4th](#)  
[\\$- variable](#)  
[\\$? variable](#) [2nd](#) [3rd](#) [4th](#) [5th](#) [6th](#) [7th](#)  
[@\\$ variable](#) [2nd](#) [3rd](#) [4th](#)  
[\\${#array\[i\]} construct](#)  
[\\${#parameter} construct](#)  
[\\${#variable} construct](#) [2nd](#)  
[\\${array\[\\*\]} construct](#)  
[\\${array\[i\]} construct](#) [2nd](#)  
[\\${n} variable](#)  
[\\${parameter##pattern} construct](#)  
[\\${parameter#pattern} construct](#)  
[\\${parameter%pattern} construct](#)  
[\\${parameter+value} construct](#)  
[\\${parameter-value} construct](#)  
[\\${parameter=value} construct](#)  
[\\${parameter?value} construct](#)  
[\\${parameter\[colon\]+value} construct](#) [2nd](#) [3rd](#)  
[\\${parameter\[colon\]-value} construct](#) [2nd](#) [3rd](#)  
[\\${parameter\[colon\]=value} construct](#) [2nd](#) [3rd](#)  
[\\${parameter\[colon\]?value} construct](#) [2nd](#) [3rd](#)  
[\\${parameter} construct](#) [2nd](#) [3rd](#)  
[\\${variable} construct \(\\*\\*\*italicize variable\*\)](#) [2nd](#)  
[\\$0 variable](#) [2nd](#) [3rd](#)  
[\\$array construct](#)  
[% \(percent sign\)](#) [2nd](#)  
[& \(ampersand\)](#)  
[&& construct](#) [2nd](#) [3rd](#) [4th](#) [5th](#) [6th](#) [7th](#) [8th](#) [9th](#)  
[< redirection operator](#)  
[<& redirection operator](#)  
[<&- characters](#)  
[<&- redirection operator](#)  
[<< redirection characters](#) [2nd](#) [3rd](#) [4th](#)  
[<< redirection operator](#)  
[<\[left angle bracket\] redirection operator](#)  
[' \(single quote\)](#) [2nd](#) [3rd](#) [4th](#) [5th](#) [6th](#) [7th](#)  
[\(\(...\)\) construct](#)

[\(\)](#) (parentheses) [2nd](#)  
[\(...\)](#) construct [2nd](#) [3rd](#) [4th](#) [5th](#)  
[\(backslash\)](#) [2nd](#) [3rd](#)  
    [backslash inside double quotes](#) [2nd](#) [3rd](#) [4th](#)  
    [line continuation character](#) [2nd](#)  
[\(double quotes\)](#) [2nd](#) [3rd](#) [4th](#) [5th](#)  
[\(semicolon\)](#)  
[\(semicolon\) command](#) (vi)  
[\\*](#) (asterisk) [2nd](#) [3rd](#) [4th](#) [5th](#) [6th](#)  
    [filename substitution](#) [2nd](#) [3rd](#) [4th](#) [5th](#)  
[\\*](#) command (vi)  
[+](#) (plus sign)  
[,](#) command (vi)  
[-](#) (hyphen)  
[-](#) option (cd command) [2nd](#)  
[--](#) option  
    [set command](#) [2nd](#) [3rd](#) [4th](#)  
[--](#) option (set command)  
[-a](#) (logical AND) operator [2nd](#)  
[-o](#) (logical OR) operator [2nd](#)  
[.](#) (period) [2nd](#) [3rd](#)  
    [. command](#) [2nd](#) [3rd](#) [4th](#) [5th](#) [6th](#) [7th](#)  
[.](#) command [2nd](#) [3rd](#) [4th](#) [5th](#)  
[.](#) pathname  
[..](#) pathname  
[...](#) construct [2nd](#) [3rd](#) [4th](#)  
[.](#)precision modifier  
[/](#) (slash)  
[/](#) command (vi) [2nd](#) [3rd](#)  
[=](#) (equal sign)  
[=](#) command (vi)  
[=](#) operator  
[?](#) (question mark)  
    [filename substitution](#) [2nd](#) [3rd](#)  
[@letter](#) command (vi) (*italic @letter*)  
[\[\\*\]](#) construct  
[\[...\]](#) construct [2nd](#) [3rd](#) [4th](#)  
[\[\]](#) (brackets)  
    [filename substitution](#) [2nd](#) [3rd](#)  
[\[colon\]](#) (null command) [2nd](#)  
[\[colon\]](#) command [2nd](#)  
[\[count\]+](#) command (vi)  
[\[count\]-](#) command (vi)  
[\[count\].](#) command (vi)  
[\[count\]/](#) command (vi)  
[\[count\]\\_](#) command (vi)  
[\[count\]b](#) command (vi)  
[\[count\]B](#) command (vi)  
[\[count\]d](#) motion command (vi) (*italic motion*)  
[\[count\]e](#) command (vi)  
[\[count\]E](#) command (vi)  
[\[count\]F](#) command (vi)

[\[count\]fc command \(vi\) \(italic c\)](#)  
[\[count\]Fc command \(vi\) \(italic c\)](#)  
[\[count\]h command \(vi\)](#)  
[\[count\]j command \(vi\)](#)  
[\[count\]k command \(vi\)](#)  
[\[count\]l command \(vi\)](#)  
[\[count\]rc command \(vi\) \(italic c\)](#)  
[\[count\]tc command \(vi\) \(italic c\)](#)  
[\[count\]Tc command \(vi\) \(italic c\)](#)  
[\[count\]v command \(vi\)](#)  
[\[count\]w command \(vi\)](#)  
[\[count\]W command \(vi\)](#)  
[\[count\]x command \(vi\)](#)  
[\[double left angle bracket\] redirection operator](#)  
[\[left angle bracket\] redirection operator](#)  
[\[left angle bracket\]& notation](#)  
[\[left angle bracket\]& redirection operator](#)  
[\[left angle bracket\]&- characters](#)  
[\[left angle bracket\]&- redirection operator](#)  
[\[left angle bracket\]|| redirection operator](#)  
[\escape character](#)  
[\escape characters](#)  
[^ \(caret\) 2nd 3rd](#)  
[^ command \(vi\)](#)  
[\\_\(underscore\) 2nd](#)  
[` \(backquote\) 2nd 3rd 4th](#)  
[{ ...\[semicolon\] } construct 2nd 3rd 4th 5th 6th](#)  
[{...} construct 2nd 3rd 4th](#)  
[{} \(braces\)](#)  
[| \(pipe symbol\) 2nd 3rd](#)  
[|| construct 2nd 3rd 4th](#)  
[pattern matching](#)  
[| \(pipe\)](#)  
[|| construct 2nd 3rd 4th 5th 6th 7th 8th 9th](#)  
[~ \(tilde\)](#)  
[tilde substitution 2nd 3rd 4th 5th](#)  
[~ command \(vi\)](#)  
[0 command \(vi\) 2nd 3rd](#)  
[0 exit status](#)  
[0 signal](#)  
[0 signal number](#)  
[1 signal](#)  
[1 signal number](#)  
[14 signal](#)  
[15 signal](#)  
[15 signal number](#)  
[2 signal](#)  
[2 signal number](#)  
[3 signal](#)  
[6 signal](#)  
[9 signal](#)





[\[SYMBOL\]](#) [\[A\]](#) [\[B\]](#) [\[C\]](#) [\[D\]](#) [\[E\]](#) [\[F\]](#) [\[G\]](#) [\[H\]](#) [\[I\]](#) [\[J\]](#) [\[K\]](#) [\[L\]](#) [\[M\]](#) [\[N\]](#) [\[O\]](#) [\[P\]](#) [\[Q\]](#) [\[R\]](#) [\[S\]](#) [\[T\]](#) [\[U\]](#) [\[V\]](#) [\[W\]](#) [\[X\]](#) [\[Y\]](#) [\[Z\]](#)

[a \( \) escape character](#)

[a command \(vi\)](#) [2nd](#) [3rd](#)

[A command \(vi\)](#)

[a option \(set command\)](#)

[ABRT signal](#)

[access modes](#)

accessing

[command history](#) [2nd](#)

[fc command](#) [2nd](#)

[history command](#) [2nd](#)

[r command](#) [2nd](#) [3rd](#)

active jobs

[printing list of](#) [2nd](#)

[add program](#) [2nd](#) [3rd](#) [4th](#) [5th](#)

[addi program](#) [2nd](#)

[Advanced Linux Programming](#)

[Advanced Perl Programming](#)

[alias command](#) [2nd](#) [3rd](#) [4th](#) [5th](#) [6th](#) [7th](#)

aliases

[defining](#) [2nd](#) [3rd](#) [4th](#) [5th](#)

[removing](#)

[allexport shell mode](#)

[ALRM signal](#)

ampersand

[&& construct](#) [2nd](#) [3rd](#) [4th](#)

[ampersand \(&\)](#)

AND operators

[logical AND operator \(-a\)](#) [2nd](#)

[apostrophe \('\)](#) [2nd](#) [3rd](#) [4th](#) [5th](#) [6th](#) [7th](#)

archive files

[creating](#) [2nd](#) [3rd](#) [4th](#) [5th](#)

[args program](#) [2nd](#) [3rd](#) [4th](#) [5th](#) [6th](#)

arguments

[functions](#)

[passing](#) [2nd](#) [3rd](#) [4th](#)

[\\$# variable](#) [2nd](#)

[\\$\\* variable](#) [2nd](#)

[\\${n} variable](#) [2nd](#)

[phonebook file example](#) [2nd](#) [3rd](#) [4th](#) [5th](#) [6th](#) [7th](#) [8th](#) [9th](#) [10th](#)

[shift command](#) [2nd](#) [3rd](#)

[positional parameters](#) [2nd](#)

[defined](#) [2nd](#)

[left shifting](#) [2nd](#) [3rd](#)

[reassigning values to](#) [2nd](#) [3rd](#)

[arithmetic operators](#) [2nd](#)

arithmetic

integer arithmetic

[arithmetic bases](#) [2nd](#) [3rd](#)

[arithmetic expressions](#) [2nd](#)

[integer types](#) [2nd](#)

[arithmetic expansion](#) [2nd](#) [3rd](#)

[arithmetic expressions](#) [2nd](#)

[arithmetically sorting files](#) [2nd](#)

[array\[i\]=val construct](#)

[arrays](#) [2nd](#) [3rd](#) [4th](#) [5th](#) [6th](#) [7th](#) [8th](#)

[assigning elements to](#)

[retrieving elements from](#)

[subscripts](#)

assigning

[values to keyword parameters](#) [2nd](#)

[variable values](#) [2nd](#) [3rd](#)

[to other variables](#)

[asterisk \(\\*\)](#) [2nd](#) [3rd](#) [4th](#) [5th](#) [6th](#) [7th](#)

[filename substitution](#) [2nd](#) [3rd](#) [4th](#) [5th](#)

[asynchronous execution](#)

[automatically loaded functions](#) [2nd](#)

[awk command](#)

[AWK Programming Language, The](#)

**Team LiB**

◀ PREVIOUS

[\[SYMBOL\]](#) [\[A\]](#) [\[B\]](#) [\[C\]](#) [\[D\]](#) [\[E\]](#) [\[F\]](#) [\[G\]](#) [\[H\]](#) [\[I\]](#) [\[J\]](#) [\[K\]](#) [\[L\]](#) [\[M\]](#) [\[N\]](#) [\[O\]](#) [\[P\]](#) [\[Q\]](#) [\[R\]](#) [\[S\]](#) [\[T\]](#) [\[U\]](#) [\[V\]](#) [\[W\]](#) [\[X\]](#) [\[Y\]](#) [\[Z\]](#)

[b \(" " \b\)escape character](#)

[b \(" " \b\)escapecharacter](#)

[b command \(vi\) 2nd](#)

[b conversion specification character](#)

[b option \(set command\)](#)

background

[executing loops in 2nd](#)

[sending commands to 2nd 3rd](#)

background processes

[waiting for 2nd 3rd 4th 5th](#)

[background, executing jobs in](#)

[background, running jobs in](#)

[backquote \(`\) 2nd 3rd 4th](#)

[backslash \(\ 2nd 3rd 4th 5th](#)

[backslash inside double quotes 2nd 3rd 4th](#)

[line continuation character 2nd](#)

[bases \(arithmetic\) 2nd 3rd](#)

Bash shell

[beginning of line, matching 2nd](#)

[bg command 2nd 3rd 4th 5th 6th](#)

books

[AWK Programming Language, The](#)

[Learning Pearl](#)

[Programming Pearl](#)

[Unix C Shell Field Guide, The](#)

[Unix in a Nutshell\[colon\] System V Edition](#)

[Unix Programmer's Manual, Volume II](#)

[Unix Programming Environment, The](#)

Bourne shell

[Bourne, Stephen 2nd](#)

[braces \({}\)](#)

brackets ([])

[filename substitution 2nd 3rd](#)

[break command 2nd 3rd 4th 5th 6th](#)

Break key

breaking

[loops 2nd](#)

[breaking loops 2nd 3rd](#)

[\[SYMBOL\]](#) [\[A\]](#) [\[B\]](#) [\[C\]](#) [\[D\]](#) [\[E\]](#) [\[F\]](#) [\[G\]](#) [\[H\]](#) [\[I\]](#) [\[J\]](#) [\[K\]](#) [\[L\]](#) [\[M\]](#) [\[N\]](#) [\[O\]](#) [\[P\]](#) [\[Q\]](#) [\[R\]](#) [\[S\]](#) [\[T\]](#) [\[U\]](#) [\[V\]](#) [\[W\]](#) [\[X\]](#) [\[Y\]](#) [\[Z\]](#)

[c \(\) escape character](#)

[c \(\) escape characters](#)

[C command \(vi\)](#)

[c conversion specification character](#)

[c option](#)

[sh command](#)

[uniq command](#)

[wc command](#)

[C option \(set command\)](#)

[caret \(^\) 2nd 3rd](#)

[case command 2nd 3rd](#)

[pattern matching characters 2nd 3rd 4th](#)

[&& construct 2nd 3rd 4th](#)

[\\* \(asterisk\) 2nd](#)

[? \(question mark\)](#)

[\[...\] construct](#)

[|| construct 2nd 3rd 4th](#)

[pipe symbol \(|\) 2nd 3rd](#)

[syntax 2nd 3rd](#)

[case statement](#)

[cat command 2nd 3rd](#)

[cd command 2nd 3rd 4th 5th 6th 7th 8th 9th](#)

[- option 2nd](#)

[cdh function 2nd 3rd 4th](#)

[CDPATH variable 2nd 3rd 4th](#)

[cdtest program](#)

[change program 2nd 3rd](#)

[changing](#)

[command prompt 2nd](#)

[directories](#)

[cd command 2nd 3rd 4th 5th](#)

[groups 2nd](#)

[characters](#)

[# \(pound sign\)](#)

[= \(equal sign\)](#)

[\\_ \(underscore\)](#)

[extracting from files](#)

[cut command 2nd 3rd 4th 5th 6th 7th 8th 9th 10th](#)

[matching](#)

[multiple characters 2nd 3rd 4th](#)

[single characters 2nd 3rd](#)

[newline characters](#)

[pattern matching](#)

[any character 2nd 3rd](#)

[beginning of line 2nd](#)

[end of line 2nd 3rd](#)

[grep command 2nd 3rd 4th 5th 6th 7th 8th 9th 10th 11th 12th 13th 14th](#)

[parameter substitution constructs 2nd 3rd 4th](#)

[precise number of characters](#) [2nd](#) [3rd](#) [4th](#)

[saving matched characters](#) [2nd](#) [3rd](#) [4th](#)

[specific characters](#) [2nd](#) [3rd](#)

[summary of regular expressions](#) [2nd](#)

[zero or more characters](#) [2nd](#) [3rd](#) [4th](#)

repeating

[echo command](#) [2nd](#)

[translating from standard input](#) [2nd](#) [3rd](#) [4th](#) [5th](#) [6th](#) [7th](#) [8th](#) [9th](#) [10th](#) [11th](#) [12th](#)

[whitespace characters](#)

[child processes](#)

closing

[standard input](#)

[standard output](#)

comamnds

[bg](#) [2nd](#) [3rd](#) [4th](#)

[comma \(,\)](#)

[command \(vi\)](#)

[command files](#) [2nd](#)

[comments](#) [2nd](#) [3rd](#) [4th](#)

[# \(pound sign\)](#)

[creating](#) [2nd](#)

[examples](#) [2nd](#) [3rd](#) [4th](#)

[execute permissions](#) [2nd](#)

[passing arguments to](#) [2nd](#) [3rd](#) [4th](#)

[\\$# variable](#) [2nd](#)

[\\$\\* variable](#) [2nd](#)

[\\${n} variable](#) [2nd](#)

[phonebook file example](#) [2nd](#) [3rd](#) [4th](#) [5th](#) [6th](#) [7th](#) [8th](#) [9th](#) [10th](#)

[shift command](#) [2nd](#) [3rd](#)

[command history](#) [2nd](#)

[.](#) [See also [edit modes](#)]

[accessing](#) [2nd](#)

[accessing with fc command](#) [2nd](#)

[accessing with history command](#) [2nd](#)

[accessing with r command](#) [2nd](#) [3rd](#)

[editing](#) [2nd](#)

[file location](#)

[size of](#)

[sizing](#) [2nd](#)

[command line](#)

command prompt

[changing](#) [2nd](#)

[command substitution](#)

[\\$\(...\) construct](#) [2nd](#) [3rd](#) [4th](#) [5th](#) [6th](#) [7th](#) [8th](#) [9th](#)

[` \(backquote\)](#) [2nd](#) [3rd](#) [4th](#)

[expr command](#) [2nd](#) [3rd](#) [4th](#) [5th](#)

[command-line editing](#) [2nd](#)

[command-line tools.](#) [See [commands](#)]

[commands](#) [2nd](#)

[.](#) [See also [command files](#), [programs](#)]

[.\(period\)](#) [2nd](#) [3rd](#) [4th](#) [5th](#) [6th](#) [7th](#)

[\[colon\]](#) [2nd](#)

[alias](#) [2nd](#) [3rd](#) [4th](#) [5th](#) [6th](#) [7th](#)  
aliases  
    [defining](#) [2nd](#) [3rd](#) [4th](#) [5th](#)  
    [removing](#)  
[awk](#)  
[bg](#) [2nd](#)  
[break](#) [2nd](#) [3rd](#) [4th](#) [5th](#) [6th](#)  
[case](#) [2nd](#) [3rd](#)  
    [pattern matching characters](#) [2nd](#) [3rd](#) [4th](#)  
    [pipe symbol \(|\)](#) [2nd](#) [3rd](#)  
    [syntax](#) [2nd](#) [3rd](#)  
[cat](#) [2nd](#) [3rd](#)  
[cd](#) [2nd](#) [3rd](#) [4th](#) [5th](#) [6th](#) [7th](#) [8th](#) [9th](#)  
    [- option](#) [2nd](#)  
[command cycle](#) [2nd](#)  
[command files](#) [2nd](#)  
    [comments](#) [2nd](#) [3rd](#) [4th](#)  
    [creating](#) [2nd](#)  
    [examples](#) [2nd](#) [3rd](#) [4th](#)  
    [execute permissions](#) [2nd](#)  
[command history](#) [2nd](#)  
    \_ [See also [edit modes](#)]  
    [accessing](#) [2nd](#)  
    [accessing with fc command](#) [2nd](#)  
    [accessing with history command](#) [2nd](#)  
    [accessing with r command](#) [2nd](#) [3rd](#)  
    [editing](#) [2nd](#)  
    [file location](#)  
    [size of](#)  
    [sizing](#) [2nd](#)  
[command options](#) [2nd](#) [3rd](#)  
[command substitution](#)  
    [\\$\(...\) construct](#) [2nd](#) [3rd](#) [4th](#) [5th](#) [6th](#) [7th](#) [8th](#) [9th](#)  
    [` \(backquote\)](#) [2nd](#) [3rd](#) [4th](#)  
    [expr command](#) [2nd](#) [3rd](#) [4th](#) [5th](#)  
[command-line editing](#) [2nd](#)  
[continue](#) [2nd](#) [3rd](#) [4th](#)  
[continuing to next line](#)  
[cp](#) [2nd](#) [3rd](#) [4th](#)  
cut  
    [-d option](#) [2nd](#) [3rd](#) [4th](#) [5th](#)  
    [-f option](#) [2nd](#) [3rd](#) [4th](#) [5th](#)  
    [examples](#) [2nd](#) [3rd](#) [4th](#)  
    [syntax](#)  
[date](#) [2nd](#) [3rd](#)  
[echo](#) [2nd](#) [3rd](#) [4th](#) [5th](#) [6th](#) [7th](#)  
    [escape characters](#) [2nd](#)  
[emacs line edit mode](#) [2nd](#)  
[entering](#) [2nd](#) [3rd](#)  
[entering multiple](#) [2nd](#)  
[eval](#) [2nd](#) [3rd](#) [4th](#) [5th](#) [6th](#)  
[exec](#) [2nd](#) [3rd](#) [4th](#) [5th](#)

[executing](#)

[asynchronous execution](#)

[executing in background](#)

[exit](#) [2nd](#) [3rd](#) [4th](#) [5th](#) [6th](#)

[exit status](#)

[export](#) [2nd](#) [3rd](#)

[-p option](#)

[expr](#) [2nd](#) [3rd](#) [4th](#) [5th](#)

[false](#)

[fc](#) [2nd](#) [3rd](#) [4th](#) [5th](#) [6th](#) [7th](#)

[fg](#) [2nd](#) [3rd](#) [4th](#) [5th](#) [6th](#)

[for](#) [2nd](#) [3rd](#)

[\\$\\* variable](#)

[\\$@ variable](#) [2nd](#) [3rd](#)

[examples](#) [2nd](#) [3rd](#) [4th](#) [5th](#)

[for without the list](#) [2nd](#)

[syntax](#) [2nd](#)

[general format of](#)

[getopts](#) [2nd](#) [3rd](#) [4th](#) [5th](#) [6th](#) [7th](#) [8th](#) [9th](#) [10th](#)

[grep](#) [2nd](#)

[-l option](#) [2nd](#)

[-n option](#) [2nd](#)

[-v option](#) [2nd](#)

[examples](#) [2nd](#) [3rd](#) [4th](#) [5th](#) [6th](#) [7th](#)

[syntax](#)

[grouping](#) [2nd](#) [3rd](#) [4th](#) [5th](#) [6th](#) [7th](#)

[hash](#) [2nd](#)

[history](#) [2nd](#)

[if](#) [2nd](#) [3rd](#) [4th](#) [5th](#)

[&& construct](#) [2nd](#) [3rd](#) [4th](#)

[|| construct](#) [2nd](#) [3rd](#) [4th](#)

[elif construct](#) [2nd](#) [3rd](#) [4th](#) [5th](#)

[else construct](#) [2nd](#) [3rd](#) [4th](#)

[exit status](#) [2nd](#) [3rd](#) [4th](#) [5th](#) [6th](#) [7th](#)

[syntax](#) [2nd](#)

[testing conditions in.](#) [See [test command](#)]

[info](#)

[jobs](#) [2nd](#) [3rd](#)

[kill](#) [2nd](#) [3rd](#) [4th](#)

[ln](#) [2nd](#) [3rd](#) [4th](#) [5th](#) [6th](#)

[ls](#) [2nd](#) [3rd](#) [4th](#) [5th](#) [6th](#)

[man](#)

[mkdir](#) [2nd](#)

[multiple commands](#)

[entering on one line](#)

[mv](#)

[moving files](#) [2nd](#)

[renaming files](#) [2nd](#) [3rd](#)

[newgrp](#) [2nd](#)

[null command \(\[colon\]\)](#) [2nd](#)

[paste](#)

[-d option](#) [2nd](#)



[-s option](#) [2nd](#)  
[examples](#) [2nd](#) [3rd](#)  
[syntax](#)

[perl](#)

[printf](#) [2nd](#) [3rd](#) [4th](#) [5th](#) [6th](#) [7th](#) [8th](#)  
[conversion specification characters](#) [2nd](#)  
[conversion specification modifiers](#) [2nd](#)  
[examples](#) [2nd](#) [3rd](#) [4th](#) [5th](#) [6th](#)  
[syntax](#)

[printing information about](#)

[ps](#) [2nd](#)

[pwd](#) [2nd](#) [3rd](#) [4th](#) [5th](#) [6th](#)

[r](#) [2nd](#) [3rd](#)

[read](#) [2nd](#) [3rd](#)  
[syntax](#) [2nd](#)

[readonly](#) [2nd](#) [3rd](#) [4th](#)

[return](#) [2nd](#) [3rd](#) [4th](#)

[returning information about](#) [2nd](#)  
[type command](#) [2nd](#)

[rm](#) [2nd](#)

[rmdir](#) [2nd](#)

[scanning twice before execution](#) [2nd](#) [3rd](#) [4th](#)

[sed](#)  
[-d option](#) [2nd](#)  
[-n option](#) [2nd](#)  
[examples](#) [2nd](#) [3rd](#) [4th](#) [5th](#)  
[syntax](#)

[sending to background](#) [2nd](#) [3rd](#)

[set](#) [2nd](#) [3rd](#) [4th](#) [5th](#) [6th](#) [7th](#) [8th](#)  
[-- option](#) [2nd](#) [3rd](#) [4th](#)  
[-x option](#) [2nd](#)  
[executing without arguments](#) [2nd](#)  
[reassigning positional parameters with](#) [2nd](#) [3rd](#)

[sh](#)  
[-x option](#) [2nd](#) [3rd](#) [4th](#)

[shift](#) [2nd](#) [3rd](#) [4th](#) [5th](#)

[sort](#) [2nd](#)  
[+ln option](#) [2nd](#)  
[-n option](#) [2nd](#)  
[-o option](#) [2nd](#)  
[-r option](#) [2nd](#)  
[-t option](#) [2nd](#) [3rd](#)  
[-u option](#) [2nd](#)

[summary of](#) [2nd](#)

[test](#) [2nd](#) [3rd](#) [4th](#)  
[alternative format](#) [2nd](#)  
[file operators](#) [2nd](#) [3rd](#)  
[integer operators](#) [2nd](#) [3rd](#)  
[logical AND operator \(-a\)](#) [2nd](#)  
[logical negation operator \(!\)](#) [2nd](#)  
[logical OR operator \(-o\)](#) [2nd](#)  
[parentheses](#) [2nd](#)

[string operators](#) [2nd](#) [3rd](#) [4th](#) [5th](#) [6th](#) [7th](#) [8th](#)

[syntax](#) [2nd](#)

[times](#) [2nd](#)

tr

[-d option](#) [2nd](#)

[-s option](#) [2nd](#)

[examples](#) [2nd](#) [3rd](#) [4th](#) [5th](#) [6th](#) [7th](#)

[syntax](#)

[trap](#) [2nd](#) [3rd](#) [4th](#) [5th](#) [6th](#) [7th](#) [8th](#)

[executing without arguments](#) [2nd](#)

[ignoring signals](#) [2nd](#)

[resetting traps](#) [2nd](#)

[signal numbers](#)

[syntax](#)

true

[type](#) [2nd](#) [3rd](#) [4th](#)

[umask](#) [2nd](#)

[unalias](#) [2nd](#)

uniq

[-c option](#)

[-d option](#) [2nd](#) [3rd](#)

[examples](#) [2nd](#) [3rd](#)

[syntax](#)

[unset](#) [2nd](#) [3rd](#) [4th](#)

[until](#) [2nd](#) [3rd](#) [4th](#) [5th](#) [6th](#) [7th](#) [8th](#) [9th](#) [10th](#) [11th](#)

[examples](#) [2nd](#) [3rd](#) [4th](#) [5th](#) [6th](#) [7th](#) [8th](#)

[syntax](#) [2nd](#)

[vi line edit mode](#) [2nd](#) [3rd](#) [4th](#) [5th](#) [6th](#) [7th](#)

[\\$](#) [2nd](#)

[/](#) [2nd](#) [3rd](#)

[O](#) [2nd](#)

[a](#) [2nd](#)

[b](#) [2nd](#)

[commands](#) [2nd](#) [3rd](#) [4th](#)

[dw](#)

[h](#) [2nd](#) [3rd](#)

[i](#) [2nd](#)

[j](#) [2nd](#) [3rd](#)

[k](#) [2nd](#) [3rd](#)

[l](#) [2nd](#) [3rd](#)

[r](#)

[w](#) [2nd](#)

[x](#) [2nd](#) [3rd](#)

[wait](#) [2nd](#)

[\\$! variable](#) [2nd](#)

[example](#)

[syntax](#) [2nd](#)

[while](#) [2nd](#) [3rd](#) [4th](#) [5th](#)

[who](#) [2nd](#)

[wv](#) [2nd](#)

commaneds

read

[exit status](#) [2nd](#) [3rd](#) [4th](#) [5th](#)

commans

[executing](#) [2nd](#) [3rd](#) [4th](#)

[comments](#) [2nd](#) [3rd](#) [4th](#) [5th](#)

[comments# \(pound sign\)](#)

comparing values

case command

[command syntax](#) [2nd](#) [3rd](#)

[pattern matching characters](#) [2nd](#) [3rd](#) [4th](#)

[pipe symbol \(|\)](#) [2nd](#) [3rd](#)

[compatibility of shells](#) [2nd](#)

contents of files

displaying

[cat command](#) [2nd](#)

[continuation character \(](#)

[continue command](#) [2nd](#) [3rd](#) [4th](#)

[conversion specification characters](#) [2nd](#)

[conversion specification modifiers](#) [2nd](#)

[Coorinated Universal Time](#)

copying

files

[checking destination files](#) [2nd](#) [3rd](#)

[cp command](#) [2nd](#) [3rd](#) [4th](#)

[echo escape characters](#) [2nd](#)

[final code listing](#) [2nd](#) [3rd](#) [4th](#) [5th](#) [6th](#)

[initial code listing](#) [2nd](#) [3rd](#)

[read command](#)

counting

words in files

[wc command](#) [2nd](#)

[cp command](#) [2nd](#) [3rd](#) [4th](#)

[Ctrl+j command \(vi\)](#)

[Ctrl+l command \(vi\)](#)

[Ctrl+m command \(vi\)](#)

[Ctrl+v command \(vi\)](#)

[Ctrl+w command \(vi\)](#)

[curly braces \({}\)](#)

[current directory](#) [2nd](#)

[current program, replacing with new program](#) [2nd](#) [3rd](#)

current working directories

changing

[cd command](#) [2nd](#) [3rd](#) [4th](#) [5th](#)

[defined](#)

displaying

[pwd command](#) [2nd](#)

cut command

[-d option](#) [2nd](#) [3rd](#) [4th](#) [5th](#)

[-f option](#) [2nd](#) [3rd](#) [4th](#) [5th](#)

[examples](#) [2nd](#) [3rd](#) [4th](#)

[syntax](#)

Cygwin

[Web site](#)



[\[SYMBOL\]](#) [\[A\]](#) [\[B\]](#) [\[C\]](#) [\[D\]](#) [\[E\]](#) [\[F\]](#) [\[G\]](#) [\[H\]](#) [\[I\]](#) [\[J\]](#) [\[K\]](#) [\[L\]](#) [\[M\]](#) [\[N\]](#) [\[O\]](#) [\[P\]](#) [\[Q\]](#) [\[R\]](#) [\[S\]](#) [\[T\]](#) [\[U\]](#) [\[V\]](#) [\[W\]](#) [\[X\]](#) [\[Y\]](#) [\[Z\]](#)

[d \(-d\) operator](#)

[D command \(vi\)](#)

[d conversion specification character](#)

d option

[cut command](#) [2nd](#) [3rd](#) [4th](#) [5th](#)

[paste command](#) [2nd](#)

[sed command](#) [2nd](#)

[uniq command](#) [2nd](#) [3rd](#)

d options

[tr command](#) [2nd](#)

[dangling symbolic links](#)

[data types](#)

[integer](#) [2nd](#)

[date command](#) [2nd](#) [3rd](#)

date/time

displaying

[date command](#) [2nd](#)

defining

[aliases](#) [2nd](#) [3rd](#) [4th](#) [5th](#)

[functions](#) [2nd](#)

[Delete key](#) [2nd](#)

deleting

[aliases](#)

directories

[rmdir command](#) [2nd](#)

[duplicate lines](#) [2nd](#)

files

[rm command](#) [2nd](#)

[function definitions](#) [2nd](#)

lines of text

[sed command](#) [2nd](#)

[phone book entries](#) [2nd](#) [3rd](#) [4th](#) [5th](#) [6th](#) [7th](#) [8th](#) [9th](#) [10th](#) [11th](#) [12th](#) [13th](#)

[variable definitions](#) [2nd](#)

delimiter characters

[sort command](#) [2nd](#) [3rd](#)

design

[rolodex program](#) [2nd](#)

[destination files](#)

[checking](#) [2nd](#) [3rd](#)

[directories](#) [2nd](#) [3rd](#) [4th](#)

[.](#) [See also [files](#)]

changing

[cd command](#) [2nd](#) [3rd](#) [4th](#) [5th](#)

[copying files between](#) [2nd](#)

creating

[mkdir command](#) [2nd](#)

[current directory](#) [2nd](#)

current working directories

[changing](#) [2nd](#) [3rd](#) [4th](#) [5th](#)  
[defined](#)  
[displaying](#) [2nd](#)  
deleting  
[rmdir command](#) [2nd](#)  
[directory structure](#) [2nd](#)  
[home directories](#)  
[identifying](#) [2nd](#)  
listing files in  
[ls command](#) [2nd](#) [3rd](#) [4th](#)  
[moving files between](#) [2nd](#)  
[parent directories](#)  
[pathnames](#) [2nd](#)  
[. pathname](#)  
[.. pathname](#)  
[full pathnames](#)  
[relative pathnames](#)  
[root directories](#)  
working directory  
[printing](#) [2nd](#)  
disabling  
[trace mode](#)  
[display program](#) [2nd](#)  
displaying  
current working directory  
[pwd command](#) [2nd](#)  
date/time  
[date command](#) [2nd](#)  
file contents  
[cat command](#) [2nd](#)  
list of files  
[ls command](#) [2nd](#) [3rd](#) [4th](#) [5th](#) [6th](#)  
[list of variables](#) [2nd](#)  
logged-in users  
[who command](#) [2nd](#)  
[phone book entries](#) [2nd](#) [3rd](#) [4th](#)  
[traps](#) [2nd](#)  
[variable values](#)  
documentation  
[man pages](#)  
[tutorials](#)  
[Web sites](#) [2nd](#)  
[Cygwin](#)  
[Free Software Foundation](#)  
[Korn shell](#) [2nd](#)  
[POSIX standard](#)  
[dollar sign \(\\$\)](#) [2nd](#) [3rd](#) [4th](#) [5th](#)  
[double quotes \(\)](#) [2nd](#) [3rd](#) [4th](#) [5th](#)  
downloading  
[Korn shell](#)  
duplicate lines  
[deleting](#) [2nd](#)

duplicating

[lines](#) [2nd](#) [3rd](#) [4th](#) [5th](#) [6th](#) [7th](#) [8th](#)

[dw command \(vi\)](#)

**Team LiB**

◀ PREVIOUS

[\[SYMBOL\]](#) [\[A\]](#) [\[B\]](#) [\[C\]](#) [\[D\]](#) [\[E\]](#) [\[F\]](#) [\[G\]](#) [\[H\]](#) [\[I\]](#) [\[J\]](#) [\[K\]](#) [\[L\]](#) [\[M\]](#) [\[N\]](#) [\[O\]](#) [\[P\]](#) [\[Q\]](#) [\[R\]](#) [\[S\]](#) [\[T\]](#) [\[U\]](#) [\[V\]](#) [\[W\]](#) [\[X\]](#) [\[Y\]](#) [\[Z\]](#)

## [e \(-e\) operator](#)

[e option](#)

[fc command](#)

[e option \(set command\)](#)

[echo command](#) [2nd](#) [3rd](#) [4th](#) [5th](#) [6th](#) [7th](#)

[escape characters](#) [2nd](#)

[edit mode commands \(vi\)](#) [2nd](#) [3rd](#)

[edit modes](#)

[emacs](#) [2nd](#) [3rd](#) [4th](#) [5th](#) [6th](#) [7th](#) [8th](#)

[commands](#) [2nd](#)

[cursor](#) [2nd](#)

[vi](#) [2nd](#) [3rd](#) [4th](#) [5th](#) [6th](#)

[command mode](#)

[commands](#) [2nd](#) [3rd](#) [4th](#) [5th](#) [6th](#) [7th](#) [8th](#) [9th](#) [10th](#) [11th](#) [12th](#) [13th](#) [14th](#) [15th](#) [16th](#) [17th](#) [18th](#) [19th](#) [20th](#)

[input mode](#)

[editing](#)

[command history](#) [2nd](#)

[command-line editing](#) [2nd](#)

[files](#)

[sed command](#) [2nd](#) [3rd](#) [4th](#) [5th](#) [6th](#) [7th](#) [8th](#) [9th](#) [10th](#) [11th](#)

[phone book entries](#) [2nd](#) [3rd](#)

[editors](#)

[stream editor \(sed\)](#)

[-d option](#) [2nd](#)

[-n option](#) [2nd](#)

[examples](#) [2nd](#) [3rd](#) [4th](#) [5th](#)

[syntax](#)

[elements of arrays](#)

[assigning](#)

[retrieving](#)

[elif construct](#) [2nd](#) [3rd](#) [4th](#) [5th](#)

[else construct](#) [2nd](#) [3rd](#) [4th](#)

[emacs line edit mode](#) [2nd](#) [3rd](#) [4th](#) [5th](#) [6th](#) [7th](#) [8th](#)

[commands](#) [2nd](#)

[cursor](#) [2nd](#)

[enabling](#)

[trace mode](#) [2nd](#)

[end of line, matching](#) [2nd](#) [3rd](#)

[Enter command \(vi\)](#) [2nd](#)

[entering](#)

[commands](#) [2nd](#) [3rd](#)

[loops on one line](#) [2nd](#) [3rd](#)

[entering multiple commands on one line](#)

[entries \(phone book\)](#)

[adding](#) [2nd](#)

[deleting](#) [2nd](#) [3rd](#) [4th](#) [5th](#) [6th](#) [7th](#) [8th](#) [9th](#)

[displaying](#) [2nd](#)

[editing](#) [2nd](#) [3rd](#)



[listing](#) [2nd](#) [3rd](#)  
[looking up](#) [2nd](#)  
[rolo program listing](#) [2nd](#) [3rd](#) [4th](#) [5th](#)  
[ENV files](#) [2nd](#)  
[ENV variable](#) [2nd](#)  
environment  
  [.](#) [See also [variables](#)]  
  [defined](#)  
  [ENV file](#) [2nd](#)  
  [subshells](#) [2nd](#)  
[environmental control](#)  
[eof command \(vi\)](#)  
[eq \(-eq\) operator](#)  
[equal sign \(=\)](#) [2nd](#) [3rd](#)  
[erase command \(vi\)](#)  
[errexit shell mode](#)  
errors  
  [standard error](#) [2nd](#) [3rd](#)  
[ESC command \(vi\)](#)  
[escape character](#)  
[escape characters](#)  
  [echo command](#) [2nd](#)  
[eval command](#) [2nd](#) [3rd](#) [4th](#) [5th](#) [6th](#)  
evaluating  
  expressions  
    [expr command](#) [2nd](#) [3rd](#) [4th](#) [5th](#)  
[exec command](#) [2nd](#) [3rd](#) [4th](#) [5th](#)  
execute permissions  
  [command files](#) [2nd](#)  
executing  
  [commands](#) [2nd](#) [3rd](#) [4th](#)  
    [asynchronous execution](#)  
    [background execution](#)  
    [scanning twice before execution](#) [2nd](#) [3rd](#) [4th](#)  
    [file contents in current shell](#) [2nd](#) [3rd](#) [4th](#) [5th](#)  
    [functions](#) [2nd](#)  
    [terminating execution](#) [2nd](#)  
  jobs  
    [background execution](#) [2nd](#)  
    [foreground execution](#) [2nd](#)  
  loops  
    [background execution](#) [2nd](#)  
exercises  
  [chapter 1](#) [2nd](#) [3rd](#)  
  [chapter 10](#)  
  [chapter 11](#) [2nd](#) [3rd](#)  
  [chapter 12](#) [2nd](#) [3rd](#)  
  [chapter 13](#) [2nd](#)  
  [chapter 14](#) [2nd](#) [3rd](#)  
  [chapter 15](#) [2nd](#) [3rd](#)  
  [chapter 4](#)  
  [chapter 5](#) [2nd](#) [3rd](#)

[chapter 6](#) [2nd](#)  
[chapter 7](#) [2nd](#) [3rd](#)  
[chapter 8](#) [2nd](#) [3rd](#)  
[chapter 9](#) [2nd](#) [3rd](#)  
[exit command](#) [2nd](#) [3rd](#) [4th](#) [5th](#) [6th](#)  
[EXIT signal](#)  
[exit status](#) [2nd](#) [3rd](#)  
     [\\$? variable](#) [2nd](#) [3rd](#) [4th](#) [5th](#) [6th](#)  
    [nonzero values](#)  
    [read command](#) [2nd](#) [3rd](#) [4th](#) [5th](#)  
    [zero](#)  
exiting  
    loops  
        [break command](#) [2nd](#) [3rd](#)  
        [programs](#) [2nd](#)  
expansion  
    [arithmetic expansion](#) [2nd](#) [3rd](#)  
[export command](#) [2nd](#) [3rd](#)  
    [-p option](#)  
[exported variables](#) [2nd](#) [3rd](#) [4th](#) [5th](#) [6th](#) [7th](#)  
exporting  
    [variables](#) [2nd](#) [3rd](#) [4th](#) [5th](#) [6th](#) [7th](#) [8th](#) [9th](#) [10th](#)  
expressions  
    [arithmetic expressions](#) [2nd](#) [3rd](#) [4th](#)  
    evaluating  
        [expr command](#) [2nd](#) [3rd](#) [4th](#) [5th](#)  
[expressions \(regular expressions\)](#) [2nd](#)  
    [... construct](#) [2nd](#) [3rd](#) [4th](#)  
    [\[...\] construct](#) [2nd](#) [3rd](#)  
    [{...} construct](#) [2nd](#) [3rd](#) [4th](#)  
    [asterisk \(\\*\)](#) [2nd](#) [3rd](#) [4th](#)  
    [caret \(^\)](#) [2nd](#)  
    [dollar sign \(\\$\)](#) [2nd](#) [3rd](#)  
grep command  
    [-l option](#) [2nd](#)  
    [-n option](#) [2nd](#)  
    [-v option](#) [2nd](#)  
    [examples](#) [2nd](#) [3rd](#) [4th](#) [5th](#) [6th](#) [7th](#)  
    [syntax](#)  
    [period \(.\)](#) [2nd](#) [3rd](#)  
    [summary of](#) [2nd](#)  
extracting  
    characters from files  
        [cut command](#) [2nd](#) [3rd](#) [4th](#) [5th](#) [6th](#) [7th](#) [8th](#) [9th](#) [10th](#)

[\[SYMBOL\]](#) [\[A\]](#) [\[B\]](#) [\[C\]](#) [\[D\]](#) [\[E\]](#) [\[F\]](#) [\[G\]](#) [\[H\]](#) [\[I\]](#) [\[J\]](#) [\[K\]](#) [\[L\]](#) [\[M\]](#) [\[N\]](#) [\[O\]](#) [\[P\]](#) [\[Q\]](#) [\[R\]](#) [\[S\]](#) [\[T\]](#) [\[U\]](#) [\[V\]](#) [\[W\]](#) [\[X\]](#) [\[Y\]](#) [\[Z\]](#)

[f \(" " \f \)escapecharacter](#)

[f \(" " \f \)escapecharacter](#)

[f \(-f\) operator](#)

[F command \(vi\)](#)

[f option](#)

[cut command](#) [2nd](#) [3rd](#) [4th](#) [5th](#)

[f option \(set command\)](#)

[false command](#)

[fc command](#) [2nd](#) [3rd](#) [4th](#) [5th](#) [6th](#) [7th](#)

[FCEDIT variable](#) [2nd](#)

[fg command](#) [2nd](#) [3rd](#) [4th](#) [5th](#) [6th](#)

[fields](#)

[Input Field Separator \(IFS\) variable](#) [2nd](#) [3rd](#) [4th](#) [5th](#)

[skipping during sorts](#) [2nd](#)

[file descriptors](#)

[file operators](#) [2nd](#) [3rd](#)

[filename substitution](#) [2nd](#) [3rd](#) [4th](#)

[\\* \(asterisk\)](#) [2nd](#) [3rd](#) [4th](#)

[? \(question mark\)](#) [2nd](#)

[\[\] \(brackets\)](#) [2nd](#)

[examples](#) [2nd](#)

[multiple character matching](#) [2nd](#) [3rd](#) [4th](#)

[single character matching](#) [2nd](#) [3rd](#)

[variables](#) [2nd](#) [3rd](#)

[filenames](#)

[filename substitution](#) [2nd](#) [3rd](#) [4th](#)

[\\* \(asterisk\)](#) [2nd](#) [3rd](#) [4th](#)

[? \(question mark\)](#) [2nd](#)

[\[\] \(brackets\)](#) [2nd](#)

[examples](#) [2nd](#)

[multiple character matching](#) [2nd](#) [3rd](#) [4th](#)

[single character matching](#) [2nd](#) [3rd](#)

[variables](#) [2nd](#) [3rd](#)

[files](#)

[.](#) [See also [directories](#)]

[.profile](#) [2nd](#) [3rd](#)

[archive files](#)

[creating](#) [2nd](#) [3rd](#) [4th](#) [5th](#)

[command files](#) [2nd](#)

[comments](#) [2nd](#) [3rd](#) [4th](#)

[creating](#) [2nd](#)

[examples](#) [2nd](#) [3rd](#) [4th](#)

[execute permissions](#) [2nd](#)

[command history file.](#) [See [command history](#)]

[copying](#)

[checking destination files](#) [2nd](#) [3rd](#)

[cp command](#) [2nd](#) [3rd](#) [4th](#)

[echo escape characters](#) [2nd](#)

[final code listing](#) [2nd](#) [3rd](#) [4th](#) [5th](#) [6th](#)  
[initial code listing](#) [2nd](#) [3rd](#)  
[read command](#)  
counting words in  
[wc command](#) [2nd](#)  
deleting  
[rm command](#) [2nd](#)  
[destination files](#)  
displaying contents of  
[cat command](#) [2nd](#)  
[duplicating lines in](#) [2nd](#) [3rd](#) [4th](#) [5th](#) [6th](#) [7th](#) [8th](#)  
editing  
[sed command](#) [2nd](#) [3rd](#) [4th](#) [5th](#) [6th](#) [7th](#) [8th](#) [9th](#) [10th](#) [11th](#)  
[ENV files](#) [2nd](#)  
[executing contents in current shell](#) [2nd](#) [3rd](#) [4th](#) [5th](#)  
extracting characters from  
[cut command](#) [2nd](#) [3rd](#) [4th](#) [5th](#) [6th](#) [7th](#) [8th](#) [9th](#) [10th](#)  
[file descriptors](#)  
[file operators](#) [2nd](#) [3rd](#)  
[filename substitution](#) [2nd](#) [3rd](#) [4th](#)  
[\\* \(asterisk\)](#) [2nd](#) [3rd](#) [4th](#)  
[? \(question mark\)](#) [2nd](#)  
[\[\] \(brackets\)](#) [2nd](#)  
[examples](#) [2nd](#)  
[multiple character matching](#) [2nd](#) [3rd](#) [4th](#)  
[single character matching](#) [2nd](#) [3rd](#)  
[variables](#) [2nd](#) [3rd](#)  
[filenames](#)  
linking  
[dangling symbolic links](#)  
[ln command](#) [2nd](#) [3rd](#) [4th](#) [5th](#) [6th](#)  
[symbolic links](#) [2nd](#)  
listing  
[ls command](#) [2nd](#) [3rd](#) [4th](#) [5th](#) [6th](#)  
moving between directories  
[mv command](#) [2nd](#)  
[ordinary files](#)  
paths  
[CDPATH variable](#) [2nd](#) [3rd](#) [4th](#)  
[PATH variable](#) [2nd](#) [3rd](#) [4th](#) [5th](#) [6th](#) [7th](#) [8th](#) [9th](#) [10th](#) [11th](#) [12th](#) [13th](#) [14th](#)  
phonebook file  
[adding entries to](#) [2nd](#) [3rd](#)  
[deleting entries from](#) [2nd](#) [3rd](#) [4th](#)  
[looking up entries](#) [2nd](#) [3rd](#)  
[reading data from](#) [2nd](#)  
renaming  
[mv command](#) [2nd](#) [3rd](#)  
searching  
[grep command](#) [2nd](#) [3rd](#) [4th](#) [5th](#) [6th](#) [7th](#) [8th](#) [9th](#) [10th](#)  
[sorting](#) [2nd](#)  
[arithmetic sorts](#) [2nd](#)  
[delimiter characters](#) [2nd](#) [3rd](#)

[duplicate lines](#) [2nd](#)  
[reversing sort order](#) [2nd](#)  
[skipped fields](#) [2nd](#)  
[writing sorted data to standard output](#) [2nd](#)

[source files](#)  
[special files](#)  
[temporary files](#) [2nd](#) [3rd](#)

files

[reading](#)  
[. command](#)

[filters](#) [2nd](#)

finding

[home directories](#) [2nd](#)  
[phone book entries](#) [2nd](#) [3rd](#) [4th](#) [5th](#)

[for command](#) [2nd](#) [3rd](#)

[\\$\\* variable](#)  
[\\$@ variable](#) [2nd](#) [3rd](#)  
[examples](#) [2nd](#) [3rd](#) [4th](#) [5th](#)  
[for without the list](#) [2nd](#)  
[syntax](#) [2nd](#)

[foreground, executing jobs in](#)

[foreground, running jobs in](#)

formatted output

[printing](#) [2nd](#) [3rd](#) [4th](#) [5th](#) [6th](#) [7th](#)  
[command syntax](#)  
[conversion specification characters](#) [2nd](#)  
[conversion specification modifiers](#) [2nd](#)  
[examples](#) [2nd](#) [3rd](#) [4th](#) [5th](#) [6th](#)

[Fox, Brian](#)

[FPATH variable](#)

Free Software Foundation

[Web site](#)

[FreeBSD Unleashed](#)

[full pathnames](#)

[functions](#) [2nd](#) [3rd](#)

[advantages](#) [2nd](#)  
[arguments](#)  
[automatically loaded functions](#) [2nd](#)  
[cdh](#) [2nd](#) [3rd](#) [4th](#)  
[defining](#) [2nd](#)  
[deleting](#) [2nd](#)  
[executing](#) [2nd](#)  
[mycd function](#) [2nd](#)  
[recursive functions](#) [2nd](#)  
[stopping execution of](#)  
[terminating execution of](#) [2nd](#)

[\[SYMBOL\]](#) [\[A\]](#) [\[B\]](#) [\[C\]](#) [\[D\]](#) [\[E\]](#) [\[F\]](#) [\[G\]](#) [\[H\]](#) [\[I\]](#) [\[J\]](#) [\[K\]](#) [\[L\]](#) [\[M\]](#) [\[N\]](#) [\[O\]](#) [\[P\]](#) [\[Q\]](#) [\[R\]](#) [\[S\]](#) [\[T\]](#) [\[U\]](#) [\[V\]](#) [\[W\]](#) [\[X\]](#) [\[Y\]](#) [\[Z\]](#)

[ge \(-ge\) operator](#)

[getopts command](#) [2nd](#) [3rd](#) [4th](#) [5th](#) [6th](#) [7th](#) [8th](#) [9th](#) [10th](#)

[getty program](#) [2nd](#)

[Greenwich Mean Time](#)

[greg command](#)

[-l option](#) [2nd](#)

[-n option](#) [2nd](#)

[-v option](#) [2nd](#)

[examples](#) [2nd](#) [3rd](#) [4th](#) [5th](#) [6th](#) [7th](#)

[syntax](#)

[grep command](#) [2nd](#)

[grouping](#)

[commands](#) [2nd](#) [3rd](#) [4th](#) [5th](#) [6th](#) [7th](#) [8th](#)

[groups](#)

[changing](#) [2nd](#)

[gt \(-gt\) operator](#)

[\[SYMBOL\]](#) [\[A\]](#) [\[B\]](#) [\[C\]](#) [\[D\]](#) [\[E\]](#) [\[F\]](#) [\[G\]](#) [\[H\]](#) [\[I\]](#) [\[J\]](#) [\[K\]](#) [\[L\]](#) [\[M\]](#) [\[N\]](#) [\[O\]](#) [\[P\]](#) [\[Q\]](#) [\[R\]](#) [\[S\]](#) [\[T\]](#) [\[U\]](#) [\[V\]](#) [\[W\]](#) [\[X\]](#) [\[Y\]](#) [\[Z\]](#)

[h command \(vi\)](#) [2nd](#) [3rd](#)

[h option \(set command\)](#)

[hash command](#) [2nd](#)

[hierarchical directory structure](#) [2nd](#)

[HISTFILE variable](#) [2nd](#)

[history command](#) [2nd](#)

[history file.](#) [See [command history](#)]

[HISTSIZ variable](#) [2nd](#)

[home directories](#)

[identifying](#) [2nd](#)

[HOME variable](#) [2nd](#) [3rd](#)

[HUP signal](#)

[hyphen \(-\)](#)

[\[SYMBOL\]](#) [\[A\]](#) [\[B\]](#) [\[C\]](#) [\[D\]](#) [\[E\]](#) [\[F\]](#) [\[G\]](#) [\[H\]](#) [\[I\]](#) [\[J\]](#) [\[K\]](#) [\[L\]](#) [\[M\]](#) [\[N\]](#) [\[O\]](#) [\[P\]](#) [\[Q\]](#) [\[R\]](#) [\[S\]](#) [\[T\]](#) [\[U\]](#) [\[V\]](#) [\[W\]](#) [\[X\]](#) [\[Y\]](#) [\[Z\]](#)

[i command \(vi\)](#) [2nd](#) [3rd](#)

[I command \(vi\)](#)

i option

[sh command](#)

[I/O \(input/output\)](#) [2nd](#)

[filters](#) [2nd](#)

formatted output

[conversion specification characters](#) [2nd](#)

[conversion specification modifiers](#) [2nd](#)

[printing](#) [2nd](#) [3rd](#) [4th](#) [5th](#) [6th](#) [7th](#) [8th](#) [9th](#) [10th](#) [11th](#) [12th](#) [13th](#) [14th](#)

[in-line input redirection](#) [2nd](#) [3rd](#) [4th](#) [5th](#) [6th](#) [7th](#) [8th](#) [9th](#)

[creating archives with](#) [2nd](#) [3rd](#) [4th](#) [5th](#)

[example](#) [2nd](#) [3rd](#) [4th](#)

[input redirection](#) [2nd](#) [3rd](#) [4th](#) [5th](#) [6th](#) [7th](#) [8th](#)

[loops](#) [2nd](#)

[output redirection](#) [2nd](#) [3rd](#) [4th](#) [5th](#) [6th](#) [7th](#) [8th](#)

[loops](#) [2nd](#)

[pipes](#) [2nd](#) [3rd](#) [4th](#)

[pipeline hookup](#) [2nd](#)

[standard error](#) [2nd](#) [3rd](#)

[redirecting](#)

[writing to](#) [2nd](#)

[standard input](#) [2nd](#) [3rd](#) [4th](#)

[closing](#)

[translating characters from](#) [2nd](#) [3rd](#) [4th](#) [5th](#) [6th](#) [7th](#) [8th](#) [9th](#) [10th](#) [11th](#) [12th](#)

[standard output](#) [2nd](#) [3rd](#) [4th](#)

[closing](#)

[writing sorted data to](#) [2nd](#)

[stream editor \(sed\)](#)

[-d option](#) [2nd](#)

[-n option](#) [2nd](#)

[examples](#) [2nd](#) [3rd](#) [4th](#) [5th](#)

[syntax](#)

IDs

[job\\_ids](#) [2nd](#)

[PIDs \(process ids\)](#) [2nd](#)

[PPIDs \(parent process ids\)](#)

[if command](#) [2nd](#) [3rd](#) [4th](#) [5th](#)

[&& construct](#) [2nd](#) [3rd](#) [4th](#)

[|| construct](#) [2nd](#) [3rd](#) [4th](#)

[elif construct](#) [2nd](#) [3rd](#) [4th](#) [5th](#)

[else construct](#) [2nd](#) [3rd](#) [4th](#)

[exit status](#)

[\\$? variable](#) [2nd](#) [3rd](#) [4th](#) [5th](#) [6th](#)

[nonzero values](#)

[zero values](#)

[syntax](#) [2nd](#)

[testing conditions in.](#) [See [test command](#)]



[IFS variable](#) [2nd](#) [3rd](#) [4th](#) [5th](#) [6th](#)

[ignoreeof shell mode](#)

ignoring

[signals](#) [2nd](#)

[in-line input redirection](#) [2nd](#) [3rd](#) [4th](#) [5th](#) [6th](#) [7th](#) [8th](#) [9th](#)

[creating archives with](#) [2nd](#) [3rd](#) [4th](#) [5th](#)

[example](#) [2nd](#) [3rd](#) [4th](#)

[info command](#)

[init program](#) [2nd](#)

[Input Field Separator \(IFS\) variable](#) [2nd](#) [3rd](#) [4th](#) [5th](#)

[input mode commands \(vi\)](#) [2nd](#)

[input redirection](#) [2nd](#) [3rd](#) [4th](#) [5th](#) [6th](#) [7th](#) [8th](#)

[input.](#) [See [I/O \(input/output\)](#)]

[input/output.](#) [See [I/O](#)]

inserting

[phone book entries](#) [2nd](#)

[INT signal](#)

integer arithmetic

[arithmetic bases](#) [2nd](#) [3rd](#)

[arithmetic expressions](#) [2nd](#)

[integer types](#) [2nd](#)

[integer expansion](#) [2nd](#) [3rd](#)

[integer operators](#) [2nd](#) [3rd](#)

integers

[integer operators](#) [2nd](#) [3rd](#)

[interpreted programming languages](#) [2nd](#)

interrupt signals

[ignoring](#) [2nd](#)

[sending](#)

[signal numbers](#) [2nd](#)

[trapping](#) [2nd](#) [3rd](#) [4th](#) [5th](#)

ison program

[passing arguments to](#) [2nd](#)

[\[SYMBOL\]](#) [\[A\]](#) [\[B\]](#) [\[C\]](#) [\[D\]](#) [\[E\]](#) [\[F\]](#) [\[G\]](#) [\[H\]](#) [\[I\]](#) [\[J\]](#) [\[K\]](#) [\[L\]](#) [\[M\]](#) [\[N\]](#) [\[O\]](#) [\[P\]](#) [\[Q\]](#) [\[R\]](#) [\[S\]](#) [\[T\]](#) [\[U\]](#) [\[V\]](#) [\[W\]](#) [\[X\]](#) [\[Y\]](#) [\[Z\]](#)

[j command \(vi\)](#) [2nd](#) [3rd](#)

[job numbers](#)

[job\\_ids](#) [2nd](#)

[jobs](#)

↳ [See also [processes](#)]

[active jobs, printing list of](#) [2nd](#)

[defined](#)

[job\\_ids](#) [2nd](#)

[killing](#) [2nd](#) [3rd](#) [4th](#)

[messages](#)

[running in background](#) [2nd](#)

[running in foreground](#) [2nd](#)

[status of](#)

[stopping](#) [2nd](#) [3rd](#) [4th](#) [5th](#) [6th](#)

[suspending](#) [2nd](#) [3rd](#) [4th](#)

[terminating](#) [2nd](#)

[jobs command](#) [2nd](#) [3rd](#)

[Joy, Bill](#)

[\[SYMBOL\]](#) [\[A\]](#) [\[B\]](#) [\[C\]](#) [\[D\]](#) [\[E\]](#) [\[F\]](#) [\[G\]](#) [\[H\]](#) [\[I\]](#) [\[J\]](#) [\[K\]](#) [\[L\]](#) [\[M\]](#) [\[N\]](#) [\[O\]](#) [\[P\]](#) [\[Q\]](#) [\[R\]](#) [\[S\]](#) [\[T\]](#) [\[U\]](#) [\[V\]](#) [\[W\]](#) [\[X\]](#) [\[Y\]](#) [\[Z\]](#)

[k command \(vi\)](#) [2nd](#) [3rd](#)

kernel

[defined](#) [2nd](#)

keys

[Break](#)

[Delete](#) [2nd](#)

[keyword parameters](#) [2nd](#)

[assigning values to](#) [2nd](#) [3rd](#) [4th](#)

[kill command](#) [2nd](#) [3rd](#) [4th](#)

[kill command \(vi\)](#)

[KILL signal](#)

killing

[jobs](#) [2nd](#) [3rd](#) [4th](#)

[Korn shell](#)

[Korn shell Web site](#) [2nd](#)

[Korn, David](#) [2nd](#)

[\[SYMBOL\]](#) [\[A\]](#) [\[B\]](#) [\[C\]](#) [\[D\]](#) [\[E\]](#) [\[F\]](#) [\[G\]](#) [\[H\]](#) [\[I\]](#) [\[J\]](#) [\[K\]](#) [\[L\]](#) [\[M\]](#) [\[N\]](#) [\[O\]](#) [\[P\]](#) [\[Q\]](#) [\[R\]](#) [\[S\]](#) [\[T\]](#) [\[U\]](#) [\[V\]](#) [\[W\]](#) [\[X\]](#) [\[Y\]](#) [\[Z\]](#)

[L \(-L\) operator](#)

[l command \(vi\)](#) [2nd](#) [3rd](#)

[L command \(vi\)](#)

l option

[grep command](#) [2nd](#)

[wc command](#)

languages

· [\[See shell programming language\]](#)

[shell programming language](#)

[comments](#)

shell programming languages

[variables](#) [2nd](#) [3rd](#) [4th](#) [5th](#) [6th](#) [7th](#) [8th](#) [9th](#) [10th](#) [11th](#) [12th](#) [13th](#) [14th](#) [15th](#) [16th](#) [17th](#) [18th](#) [19th](#) [20th](#) [21st](#)

[le \(-le\) operator](#)

[Learning Pearl](#)

[Learning Perl](#)

[left shifting positional parameters](#) [2nd](#) [3rd](#)

[line continuation character](#) [2nd](#)

[line numbering program](#) [2nd](#)

[LINENO variable](#)

lines

[\(of text\)](#)

deleting

[sed command](#) [2nd](#)

duplicate lines

[deleting](#) [2nd](#)

[duplicating](#) [2nd](#) [3rd](#) [4th](#) [5th](#) [6th](#) [7th](#) [8th](#)

[line numbering program](#) [2nd](#)

pastings together

[paste command](#) [2nd](#) [3rd](#) [4th](#) [5th](#) [6th](#) [7th](#)

pattern matching

[beginning of line](#) [2nd](#)

[end of line](#) [2nd](#) [3rd](#)

[sorting](#) [2nd](#)

[arithmetic sorts](#) [2nd](#)

[delimiter characters](#) [2nd](#) [3rd](#)

[duplicate lines](#) [2nd](#)

[reversing sort order](#) [2nd](#)

[skipped fields](#) [2nd](#)

[writing sorted data to standard output](#) [2nd](#)

linking

files

[dangling symbolic links](#)

[ln command](#) [2nd](#) [3rd](#) [4th](#) [5th](#) [6th](#)

[symbolic links](#) [2nd](#)

[Linux in a Nutshell](#)

[listall program](#) [2nd](#) [3rd](#)

listing

files

[ls command](#) [2nd](#) [3rd](#) [4th](#) [5th](#) [6th](#)  
[phone book entries](#) [2nd](#) [3rd](#)  
[variables](#) [2nd](#)

In (+ln) option  
[sort command](#) [2nd](#)

[ln command](#) [2nd](#) [3rd](#) [4th](#) [5th](#) [6th](#)  
[local variables](#) [2nd](#)

logged-in users  
displaying  
[who command](#) [2nd](#)

[logical AND operator \(-a\)](#) [2nd](#)  
[logical negation operator \(!\)](#) [2nd](#)  
[logical OR operator \(-o\)](#) [2nd](#)  
[login program](#) [2nd](#) [3rd](#)  
[login shell](#) [2nd](#) [3rd](#) [4th](#)  
[getty program](#) [2nd](#)  
[init program](#) [2nd](#)

logins  
[.profile file](#) [2nd](#) [3rd](#)  
[login cycle](#)  
[login shell](#) [2nd](#) [3rd](#) [4th](#)

looking up  
[phone book entries](#) [2nd](#)  
[looking up phone book entries](#) [2nd](#) [3rd](#)  
[loops](#) [2nd](#)  
[breaking](#) [2nd](#) [3rd](#) [4th](#) [5th](#)  
[executing in background](#) [2nd](#)

for command  
[\\$\\* variable](#)  
[\\$@ variable](#) [2nd](#) [3rd](#)  
[examples](#) [2nd](#) [3rd](#) [4th](#) [5th](#)  
[for without the list](#) [2nd](#)  
[syntax](#) [2nd](#)  
[I/O redirection](#) [2nd](#)  
[piping data into and out of](#) [2nd](#)  
[shorthand notation](#) [2nd](#) [3rd](#)  
[skipping commands in](#) [2nd](#) [3rd](#) [4th](#)  
[terminating](#) [2nd](#)  
[typing on one line](#) [2nd](#) [3rd](#)  
[until command](#) [2nd](#) [3rd](#) [4th](#) [5th](#) [6th](#) [7th](#) [8th](#)  
[examples](#) [2nd](#) [3rd](#) [4th](#) [5th](#) [6th](#) [7th](#) [8th](#)  
[syntax](#) [2nd](#)  
[while command](#) [2nd](#) [3rd](#)

[ls command](#) [2nd](#) [3rd](#) [4th](#) [5th](#) [6th](#)  
[lt \(-lt\) operator](#)  
[lu program](#) [2nd](#) [3rd](#) [4th](#) [5th](#)

[\[SYMBOL\]](#) [\[A\]](#) [\[B\]](#) [\[C\]](#) [\[D\]](#) [\[E\]](#) [\[F\]](#) [\[G\]](#) [\[H\]](#) [\[I\]](#) [\[J\]](#) [\[K\]](#) [\[L\]](#) [\[M\]](#) [\[N\]](#) [\[O\]](#) [\[P\]](#) [\[Q\]](#) [\[R\]](#) [\[S\]](#) [\[T\]](#) [\[U\]](#) [\[V\]](#) [\[W\]](#) [\[X\]](#) [\[Y\]](#) [\[Z\]](#)

[m option \(set command\)](#)

[MAIL variable](#)

[MAILCHECK variable](#)

[MAILPATH variable](#)

[man command](#)

[man pages](#)

[matching patterns](#) [2nd](#) [3rd](#) [4th](#)

[&& construct](#) [2nd](#) [3rd](#) [4th](#)

[\\* \(asterisk\)](#) [2nd](#)

[? \(question mark\)](#)

[\[...\] construct](#)

[| | construct](#) [2nd](#) [3rd](#) [4th](#)

[any character](#) [2nd](#) [3rd](#)

[beginning of line](#) [2nd](#)

[end of line](#) [2nd](#) [3rd](#)

[grep command](#)

[-l option](#) [2nd](#)

[-n option](#) [2nd](#)

[-v option](#) [2nd](#)

[examples](#) [2nd](#) [3rd](#) [4th](#) [5th](#) [6th](#) [7th](#)

[syntax](#)

[parameter substitution constructs](#) [2nd](#) [3rd](#) [4th](#)

[precise number of characters](#) [2nd](#) [3rd](#) [4th](#)

[saving matched characters](#) [2nd](#) [3rd](#) [4th](#)

[specific characters](#) [2nd](#) [3rd](#)

[summary of regular expressions](#) [2nd](#)

[zero or more characters](#) [2nd](#) [3rd](#) [4th](#)

[menu-driven phone program.](#) [See [rolodex program](#)]

[messages](#)

[job messages](#)

[mkdir command](#) [2nd](#)

[modes](#)

[access modes](#)

[trace mode](#)

[disabling](#)

[enabling](#) [2nd](#)

[vi line edit mode](#) [2nd](#) [3rd](#) [4th](#) [5th](#)

[commands](#) [2nd](#) [3rd](#) [4th](#)

[modes \(shell\)](#) [2nd](#)

[emacs](#) [2nd](#) [3rd](#) [4th](#) [5th](#) [6th](#) [7th](#) [8th](#)

[commands](#) [2nd](#)

[cursor](#) [2nd](#)

[vi](#) [2nd](#) [3rd](#) [4th](#) [5th](#) [6th](#)

[command mode](#)

[commands](#) [2nd](#) [3rd](#) [4th](#) [5th](#) [6th](#) [7th](#) [8th](#) [9th](#) [10th](#) [11th](#) [12th](#) [13th](#) [14th](#) [15th](#) [16th](#) [17th](#) [18th](#) [19th](#) [20th](#)

[input mode](#)

[mon program](#) [2nd](#) [3rd](#) [4th](#) [5th](#) [6th](#) [7th](#) [8th](#)

[monitor shell mode](#)

[mounset shell mode](#)

moving

files

[mv command](#) [2nd](#)

multiple characters

[matching](#) [2nd](#) [3rd](#) [4th](#)

multiple commands

[entering](#) [2nd](#)

[entering on one line](#)

mv command

[moving files](#) [2nd](#)

[renaming files](#) [2nd](#) [3rd](#)

[mycd function](#) [2nd](#)

mycp program

[destination files, checking](#) [2nd](#) [3rd](#)

[echo escape characters](#) [2nd](#)

[final code listing](#) [2nd](#) [3rd](#) [4th](#) [5th](#) [6th](#)

[initial code listing](#) [2nd](#) [3rd](#)

[read command](#)

[\[SYMBOL\]](#) [\[A\]](#) [\[B\]](#) [\[C\]](#) [\[D\]](#) [\[E\]](#) [\[F\]](#) [\[G\]](#) [\[H\]](#) [\[I\]](#) [\[J\]](#) [\[K\]](#) [\[L\]](#) [\[M\]](#) [\[N\]](#) [\[O\]](#) [\[P\]](#) [\[Q\]](#) [\[R\]](#) [\[S\]](#) [\[T\]](#) [\[U\]](#) [\[V\]](#) [\[W\]](#) [\[X\]](#) [\[Y\]](#) [\[Z\]](#)

[n \(\) escape character](#)

[n \(\) escape characters](#)

[n command \(vi\)](#)

[N command \(vi\)](#)

n option

[grep command](#) [2nd](#)

[sed command](#) [2nd](#)

[sort command](#) [2nd](#)

[n option \(set command\)](#)

naming

files

[mv command](#) [2nd](#) [3rd](#)

naming conventions

[filenames](#)

[pathnames](#) [2nd](#)

[. pathname](#)

[.. pathname](#)

[full pathnames](#)

[relative pathnames](#)

[variables](#)

[ne \(-ne\) operator](#)

negation operators

[logical AND operator \(-a\)](#) [2nd](#)

[logical negation operator \(!\)](#) [2nd](#)

[logical OR operator \(-o\)](#) [2nd](#)

[New KornShell Command and Programming Language, The](#)

[newgrp command](#) [2nd](#)

[newline characters](#)

[nnn escape characters \(italic n's\)](#)

[noclobber shell mode](#)

[noexec shell mode](#)

[noglob shell mode](#)

[nolog shell mode](#)

[nonzero exit status](#)

[null command \(\[colon\]\)](#) [2nd](#)

[null values](#) [2nd](#) [3rd](#)

[number program](#) [2nd](#)

[number2 program](#) [2nd](#)

numbers

[exit status](#) [2nd](#)

[\\$? variable](#) [2nd](#) [3rd](#) [4th](#) [5th](#) [6th](#)

[nonzero values](#)

[zero](#)

[job numbers](#)

[line numbering program](#) [2nd](#)

[signal numbers](#) [2nd](#) [3rd](#)



[\[SYMBOL\]](#) [\[A\]](#) [\[B\]](#) [\[C\]](#) [\[D\]](#) [\[E\]](#) [\[F\]](#) [\[G\]](#) [\[H\]](#) [\[I\]](#) [\[J\]](#) [\[K\]](#) [\[L\]](#) [\[M\]](#) [\[N\]](#) [\[O\]](#) [\[P\]](#) [\[Q\]](#) [\[R\]](#) [\[S\]](#) [\[T\]](#) [\[U\]](#) [\[V\]](#) [\[W\]](#) [\[X\]](#) [\[Y\]](#) [\[Z\]](#)

[o \(+o\) option \(set command\)](#)

[o conversion specification character](#)

[o option](#)

[sort command](#) [2nd](#)

[o option \(set command\)](#)

O'Reilly and Associates

[recommended reading](#) [2nd](#)

[Web site](#)

[operators](#) [2nd](#)

[file operators](#) [2nd](#) [3rd](#)

[integer operators](#) [2nd](#) [3rd](#)

[logical AND operator \(-a\)](#) [2nd](#)

[logical negation operator \(!\)](#) [2nd](#)

[logical OR operator \(-o\)](#) [2nd](#)

[string operators](#) [2nd](#) [3rd](#) [4th](#) [5th](#) [6th](#) [7th](#) [8th](#)

[options \(command\)](#) [2nd](#) [3rd](#)

OR operators

[logical OR operator \(-o\)](#) [2nd](#)

[ordinary files](#)

[output redirection](#) [2nd](#) [3rd](#) [4th](#) [5th](#) [6th](#) [7th](#) [8th](#)

[output.](#) [See [I/O \(input/output\)](#)]

[\[SYMBOL\]](#) [\[A\]](#) [\[B\]](#) [\[C\]](#) [\[D\]](#) [\[E\]](#) [\[F\]](#) [\[G\]](#) [\[H\]](#) [\[I\]](#) [\[J\]](#) [\[K\]](#) [\[L\]](#) [\[M\]](#) [\[N\]](#) [\[O\]](#) [\[P\]](#) [\[Q\]](#) [\[R\]](#) [\[S\]](#) [\[T\]](#) [\[U\]](#) [\[V\]](#) [\[W\]](#) [\[X\]](#) [\[Y\]](#) [\[Z\]](#)

[P command \(vi\)](#)

[p command \(vi\)](#)

[p option](#)

[export command](#)

[parameter substitution](#) [2nd](#)

[\\${#parameter} construct](#)

[\\${#variable} construct](#) [2nd](#)

[\\${parameter##pattern} construct](#)

[\\${parameter#pattern} construct](#)

[\\${parameter%pattern} construct](#)

[\\${parameter+value} construct](#)

[\\${parameter-value} construct](#)

[\\${parameter=value} construct](#)

[\\${parameter?value} construct](#)

[\\${parameter\[colon\]+value} construct](#) [2nd](#) [3rd](#)

[\\${parameter\[colon\]-value} construct](#) [2nd](#) [3rd](#)

[\\${parameter\[colon\]=value} construct](#) [2nd](#) [3rd](#)

[\\${parameter\[colon\]?value} construct](#) [2nd](#) [3rd](#)

[\\${parameter} construct](#) [2nd](#) [3rd](#)

[pattern matching constructs](#) [2nd](#) [3rd](#) [4th](#)

[parameters](#) [2nd](#) [3rd](#)

[\\_](#) [\[See also arguments, variables\]](#)[2nd](#) [\[See also variables\]](#)

[keyword parameters](#)

[assigning values to](#) [2nd](#)

[parameter substitution](#) [2nd](#) [3rd](#) [4th](#)

[\\${#parameter} construct](#)

[\\${#variable} construct](#) [2nd](#)

[\\${parameter##pattern} construct](#)

[\\${parameter#pattern} construct](#)

[\\${parameter%pattern} construct](#)

[\\${parameter+value} construct](#)

[\\${parameter-value} construct](#)

[\\${parameter=value} construct](#)

[\\${parameter?value} construct](#)

[\\${parameter\[colon\]+value} construct](#) [2nd](#) [3rd](#)

[\\${parameter\[colon\]-value} construct](#) [2nd](#) [3rd](#)

[\\${parameter\[colon\]=value} construct](#) [2nd](#) [3rd](#)

[\\${parameter\[colon\]?value} construct](#) [2nd](#) [3rd](#)

[\\${parameter} construct](#) [2nd](#) [3rd](#)

[pattern matching constructs](#) [2nd](#) [3rd](#) [4th](#)

[positional parameters](#) [2nd](#)

[reassigning values to](#) [2nd](#) [3rd](#)

[parent directories](#)

[parent process ids \(PPIDs\)](#)

[parent processes](#)

[parentheses](#) [2nd](#)

[passing](#)

[variables to subshells](#) [2nd](#) [3rd](#) [4th](#)

[passing arguments](#) [2nd](#) [3rd](#) [4th](#)

[\\$# variable](#) [2nd](#)

[\\$\\* variable](#) [2nd](#)

[\\${n} variable](#) [2nd](#)

[phonebook file example](#) [2nd](#) [3rd](#) [4th](#) [5th](#) [6th](#) [7th](#) [8th](#) [9th](#) [10th](#)

[shift command](#) [2nd](#) [3rd](#)

[paste command](#)

[-d option](#) [2nd](#)

[-s option](#) [2nd](#)

[examples](#) [2nd](#) [3rd](#)

[syntax](#)

[pasting](#)

[lines](#)

[paste command](#) [2nd](#) [3rd](#) [4th](#) [5th](#) [6th](#) [7th](#)

[PATH variable](#) [2nd](#) [3rd](#) [4th](#) [5th](#) [6th](#) [7th](#) [8th](#) [9th](#) [10th](#) [11th](#) [12th](#)

[pathnames](#) [2nd](#)

[. pathname](#)

[.. pathname](#)

[full pathnames](#)

[relative pathnames](#)

[paths](#)

[CDPATH variable](#) [2nd](#) [3rd](#) [4th](#)

[FPATH variable](#)

[PATH variable](#) [2nd](#) [3rd](#) [4th](#) [5th](#) [6th](#) [7th](#) [8th](#) [9th](#) [10th](#) [11th](#) [12th](#) [13th](#)

[pattern matching](#) [2nd](#) [3rd](#) [4th](#)

[&& construct](#) [2nd](#) [3rd](#) [4th](#)

[\\* \(asterisk\)](#) [2nd](#)

[? \(question mark\)](#)

[\[...\] construct](#)

[|| construct](#) [2nd](#) [3rd](#) [4th](#)

[any character](#) [2nd](#) [3rd](#)

[beginning of line](#) [2nd](#)

[end of line](#) [2nd](#) [3rd](#)

[grep command](#)

[-l option](#) [2nd](#)

[-n option](#) [2nd](#)

[-v option](#) [2nd](#)

[examples](#) [2nd](#) [3rd](#) [4th](#) [5th](#) [6th](#) [7th](#)

[syntax](#)

[parameter substitution constructs](#) [2nd](#) [3rd](#) [4th](#)

[precise number of characters](#) [2nd](#) [3rd](#) [4th](#)

[saving matched characters](#) [2nd](#) [3rd](#) [4th](#)

[specific characters](#) [2nd](#) [3rd](#)

[summary of regular expressions](#) [2nd](#)

[zero or more characters](#) [2nd](#) [3rd](#) [4th](#)

[percent sign \(%\)](#) [2nd](#)

[period \(.\)](#) [2nd](#) [3rd](#)

[. command](#) [2nd](#) [3rd](#) [4th](#) [5th](#) [6th](#) [7th](#)

[. pathname](#)

[.. pathname](#)

[perl command](#)

[Perl in a Nutshell](#)

permissions

execute permissions

[command files](#) [2nd](#)

phone book

[\(rolodex program\)](#)

[design considerations](#) [2nd](#)

entries

[adding](#) [2nd](#)

[deleting](#) [2nd](#) [3rd](#) [4th](#) [5th](#) [6th](#) [7th](#) [8th](#) [9th](#)

[displaying](#) [2nd](#)

[editing](#) [2nd](#) [3rd](#)

[listing](#) [2nd](#) [3rd](#)

[looking up](#) [2nd](#)

[rolo program listing](#) [2nd](#) [3rd](#) [4th](#)

[sample program output](#) [2nd](#) [3rd](#) [4th](#) [5th](#) [6th](#)

phonebook file

[adding entries to](#) [2nd](#) [3rd](#)

[deleting entries from](#) [2nd](#) [3rd](#) [4th](#)

[looking up entries](#) [2nd](#) [3rd](#)

[PHONEBOOK variable](#) [2nd](#) [3rd](#) [4th](#) [5th](#)

[PIDs \(process ids\)](#) [2nd](#)

[pipe character \(|\)](#)

[pipe symbol \(|\)](#) [2nd](#) [3rd](#)

[|| construct](#) [2nd](#) [3rd](#) [4th](#)

[pattern matching](#)

[pipes](#) [2nd](#) [3rd](#) [4th](#)

[pipeline hookup](#) [2nd](#)

[piping data into loops](#) [2nd](#)

[plus sign \(+\)](#)

pointers to variables

[creating](#)

[positional parameters](#) [2nd](#) [3rd](#) [4th](#)

[defined](#) [2nd](#)

[left shifting](#) [2nd](#) [3rd](#) [4th](#)

[reassigning values to](#) [2nd](#) [3rd](#) [4th](#) [5th](#) [6th](#)

POSIX standard

[Web site](#)

[POSIX standard shell](#)

[pound sign \(#\)](#) [2nd](#) [3rd](#) [4th](#) [5th](#) [6th](#)

[PPID variable](#)

[PPIDs \(parent process ids\)](#)

[precise number of characters, matching](#) [2nd](#) [3rd](#) [4th](#)

[printf command](#) [2nd](#) [3rd](#) [4th](#) [5th](#) [6th](#) [7th](#) [8th](#)

[conversion specification characters](#) [2nd](#)

[conversion specification modifiers](#) [2nd](#)

[examples](#) [2nd](#) [3rd](#) [4th](#) [5th](#) [6th](#)

[syntax](#)

printing

[command information](#)

[formatted output](#) [2nd](#) [3rd](#) [4th](#) [5th](#) [6th](#) [7th](#)

[command syntax](#)

[conversion specification characters](#) [2nd](#)

[conversion specification modifiers](#) [2nd](#)

[examples](#) [2nd](#) [3rd](#) [4th](#) [5th](#) [6th](#)

[job status](#)

[list of active jobs](#) [2nd](#)

[working directory](#) [2nd](#)

[process ids \(PIDs\)](#) [2nd](#)

processes

└ [See also [jobs](#)]

background processes

[waiting for](#) [2nd](#) [3rd](#) [4th](#) [5th](#)

[child processes](#)

[defined](#)

[parent processes](#)

[PIDs \(process ids\)](#) [2nd](#)

[pipeline processes](#) [2nd](#) [3rd](#)

[PPIDs \(parent process ids\)](#)

[returning status of](#) [2nd](#)

[profile \(.profile\) file](#) [2nd](#) [3rd](#)

[program loops.](#) [See [loops](#)]

[Programming Pearl](#)

[Programming Perl](#)

programs

└ [See also [command files](#), [commands](#)]

[add](#) [2nd](#) [3rd](#) [4th](#) [5th](#)

[addi](#) [2nd](#)

[args](#) [2nd](#) [3rd](#) [4th](#) [5th](#) [6th](#)

[cdtest](#)

[change](#) [2nd](#) [3rd](#)

[display](#) [2nd](#)

[exit status](#) [2nd](#)

[\\$? variable](#) [2nd](#) [3rd](#) [4th](#) [5th](#) [6th](#)

[nonzero values](#)

[zero](#)

[exiting](#) [2nd](#)

[getty](#) [2nd](#)

[init](#) [2nd](#)

interrupt signals

[ignoring](#) [2nd](#)

[sending](#)

[signal numbers](#) [2nd](#)

[trapping](#) [2nd](#) [3rd](#) [4th](#) [5th](#)

[ison](#) [2nd](#)

[listall](#) [2nd](#) [3rd](#)

[login](#) [2nd](#) [3rd](#)

[lu](#) [2nd](#) [3rd](#) [4th](#) [5th](#)

[mon](#) [2nd](#) [3rd](#) [4th](#) [5th](#) [6th](#) [7th](#) [8th](#) [9th](#)

mycp

[destination files, checking](#) [2nd](#) [3rd](#)

[echo escape characters](#) [2nd](#)

[final code listing](#) [2nd](#) [3rd](#) [4th](#) [5th](#) [6th](#)

[initial code listing](#) [2nd](#) [3rd](#)

[read command](#)

[number](#) [2nd](#)  
[number2](#) [2nd](#)  
[passing arguments to](#) [2nd](#) [3rd](#) [4th](#)  
    [\\$# variable](#) [2nd](#)  
    [\\$\\* variable](#) [2nd](#)  
    [\\${n} variable](#) [2nd](#)  
    [phonebook file example](#) [2nd](#) [3rd](#) [4th](#) [5th](#) [6th](#) [7th](#) [8th](#) [9th](#) [10th](#)  
    [shift command](#) [2nd](#) [3rd](#)  
[rem](#) [2nd](#) [3rd](#) [4th](#) [5th](#) [6th](#) [7th](#) [8th](#) [9th](#) [10th](#) [11th](#) [12th](#) [13th](#)  
[replacing current program with new program](#) [2nd](#) [3rd](#)  
[reverse](#)  
[rolo](#) [2nd](#) [3rd](#) [4th](#) [5th](#) [6th](#) [7th](#) [8th](#) [9th](#)  
    [case statement](#)  
    [echo command](#)  
    [sample runs](#) [2nd](#)  
[rolodex](#)  
    [add program](#) [2nd](#)  
    [change program](#) [2nd](#) [3rd](#)  
    [design considerations](#) [2nd](#)  
    [display program](#) [2nd](#)  
    [listall program](#) [2nd](#) [3rd](#)  
    [lu program](#) [2nd](#)  
    [PHONEBOOK variable](#) [2nd](#) [3rd](#) [4th](#) [5th](#)  
    [rem program](#) [2nd](#) [3rd](#) [4th](#) [5th](#) [6th](#) [7th](#) [8th](#) [9th](#)  
    [rolo program](#) [2nd](#) [3rd](#) [4th](#) [5th](#) [6th](#) [7th](#) [8th](#) [9th](#) [10th](#) [11th](#)  
    [sample output](#) [2nd](#) [3rd](#) [4th](#) [5th](#) [6th](#)  
    [temporary files](#) [2nd](#) [3rd](#)  
[twhile](#) [2nd](#)  
[vartest](#) [2nd](#)  
[vartest2](#) [2nd](#)  
[vartest3](#) [2nd](#)  
[vartest4](#) [2nd](#)  
[vartest5](#)  
prompts  
    [secondary prompts](#)  
[ps command](#) [2nd](#)  
[PS1 variable](#) [2nd](#) [3rd](#)  
[PS2 variable](#) [2nd](#) [3rd](#)  
[PS4 variable](#)  
[pseudo ttys](#)  
[pwd command](#) [2nd](#) [3rd](#) [4th](#) [5th](#) [6th](#)  
[PWD variable](#)

[\[SYMBOL\]](#) [\[A\]](#) [\[B\]](#) [\[C\]](#) [\[D\]](#) [\[E\]](#) [\[F\]](#) [\[G\]](#) [\[H\]](#) [\[I\]](#) [\[J\]](#) [\[K\]](#) [\[L\]](#) [\[M\]](#) [\[N\]](#) [\[O\]](#) [\[P\]](#) [\[Q\]](#) [\[R\]](#) [\[S\]](#) [\[T\]](#) [\[U\]](#) [\[V\]](#) [\[W\]](#) [\[X\]](#) [\[Y\]](#) [\[Z\]](#)

[question mark \(?\)](#)

[filename substitution](#) [2nd](#) [3rd](#)

[quote characters](#) [2nd](#)

[back quote \(`\)](#) [2nd](#) [3rd](#) [4th](#)

[backslash \(\\)](#) [2nd](#) [3rd](#)

[backslash inside double quotes](#) [2nd](#) [3rd](#) [4th](#)

[line continuation character](#) [2nd](#)

[double quotes \("\)](#) [2nd](#) [3rd](#) [4th](#) [5th](#)

[single quote \('\)](#) [2nd](#) [3rd](#) [4th](#) [5th](#) [6th](#) [7th](#)

[\[SYMBOL\]](#) [\[A\]](#) [\[B\]](#) [\[C\]](#) [\[D\]](#) [\[E\]](#) [\[F\]](#) [\[G\]](#) [\[H\]](#) [\[I\]](#) [\[J\]](#) [\[K\]](#) [\[L\]](#) [\[M\]](#) [\[N\]](#) [\[O\]](#) [\[P\]](#) [\[Q\]](#) [\[R\]](#) [\[S\]](#) [\[T\]](#) [\[U\]](#) [\[V\]](#) [\[W\]](#) [\[X\]](#) [\[Y\]](#) [\[Z\]](#)

[r \(" " \r " "\) escape character](#)

[r \(" " \r " "\) escape characters](#)

[r \(-r\) operator](#)

[r command](#) [2nd](#) [3rd](#)

[r command \(vi\)](#)

[r option](#)

[sort command](#) [2nd](#)

[read command](#) [2nd](#) [3rd](#)

[exit status](#) [2nd](#) [3rd](#) [4th](#) [5th](#)

[syntax](#) [2nd](#)

[read-only variables](#) [2nd](#)

[creating](#) [2nd](#)

[reading](#)

[files](#)

[. command](#)

[reading data](#) [2nd](#)

[readonly command](#) [2nd](#) [3rd](#) [4th](#)

[reassigning](#)

[values to positional parameters](#) [2nd](#) [3rd](#)

[recommended reading.](#) [See [books](#)]

[recursive functions](#) [2nd](#)

[Red Hat Linux 8 Unleashed](#)

[redirecting I/O \(input/output\)](#)

[loops](#) [2nd](#)

[redirection](#)

[in-line input redirection](#) [2nd](#) [3rd](#) [4th](#) [5th](#) [6th](#) [7th](#) [8th](#) [9th](#)

[creating archives with](#) [2nd](#) [3rd](#) [4th](#) [5th](#)

[example](#) [2nd](#) [3rd](#) [4th](#)

[input redirection](#) [2nd](#) [3rd](#) [4th](#) [5th](#) [6th](#) [7th](#) [8th](#)

[output redirection](#) [2nd](#) [3rd](#) [4th](#) [5th](#) [6th](#) [7th](#) [8th](#)

[standard error](#)

[regular expressions](#) [2nd](#)

[... construct](#) [2nd](#) [3rd](#) [4th](#)

[\[...\] construct](#) [2nd](#) [3rd](#)

[{...} construct](#) [2nd](#) [3rd](#) [4th](#)

[asterisk \(\\*\)](#) [2nd](#) [3rd](#) [4th](#)

[caret \(^\)](#) [2nd](#)

[dollar sign \(\\$\)](#) [2nd](#) [3rd](#)

[grep command](#)

[-l option](#) [2nd](#)

[-n option](#) [2nd](#)

[-v option](#) [2nd](#)

[examples](#) [2nd](#) [3rd](#) [4th](#) [5th](#) [6th](#) [7th](#)

[syntax](#)

[period \(.\)](#) [2nd](#) [3rd](#)

[summary of](#) [2nd](#)

[relative pathnames](#)

[rem program](#) [2nd](#) [3rd](#) [4th](#) [5th](#) [6th](#) [7th](#) [8th](#) [9th](#) [10th](#) [11th](#) [12th](#) [13th](#)



removing  
    [aliases](#)  
[removing.](#) [See [deleting](#)]  
renaming  
    files  
        [mv command](#) [2nd](#) [3rd](#)  
repeating characters  
    [echo command](#) [2nd](#)  
replacing  
    [current program with new program](#) [2nd](#) [3rd](#)  
resetting  
    [traps](#) [2nd](#)  
[restricted shell \(rsh\)](#) [2nd](#) [3rd](#) [4th](#)  
[return command](#) [2nd](#) [3rd](#) [4th](#)  
[reverse program](#)  
reversing  
    [sort order](#) [2nd](#)  
[rm command](#) [2nd](#)  
[rmdir command](#) [2nd](#)  
[rolo program](#) [2nd](#) [3rd](#) [4th](#) [5th](#) [6th](#) [7th](#) [8th](#) [9th](#)  
    [case statement](#)  
    [echo command](#)  
    [sample runs](#) [2nd](#)  
[rolodex program](#)  
    [add program](#) [2nd](#)  
    [change program](#) [2nd](#) [3rd](#)  
    [design considerations](#) [2nd](#)  
    [display program](#) [2nd](#)  
    [listall program](#) [2nd](#) [3rd](#)  
    [lu program](#) [2nd](#)  
    [PHONEBOOK variable](#) [2nd](#) [3rd](#) [4th](#) [5th](#)  
    [rem program](#) [2nd](#) [3rd](#) [4th](#) [5th](#) [6th](#) [7th](#) [8th](#) [9th](#)  
    [rolo program](#) [2nd](#) [3rd](#) [4th](#) [5th](#) [6th](#) [7th](#) [8th](#) [9th](#)  
        [case statement](#)  
        [echo command](#)  
        [sample runs](#) [2nd](#)  
        [sample output](#) [2nd](#) [3rd](#) [4th](#) [5th](#) [6th](#)  
        [temporary files](#) [2nd](#) [3rd](#)  
root directories  
[rsh \(restricted shell\)](#) [2nd](#) [3rd](#) [4th](#)  
[run command file](#)  
    [passing arguments to](#) [2nd](#)  
[running.](#) [See [executing](#)]

[[SYMBOL](#)] [[A](#)] [[B](#)] [[C](#)] [[D](#)] [[E](#)] [[F](#)] [[G](#)] [[H](#)] [[I](#)] [[J](#)] [[K](#)] [[L](#)] [[M](#)] [[N](#)] [[O](#)] [[P](#)] [[Q](#)] [[R](#)] [[S](#)] [[T](#)] [[U](#)] [[V](#)] [[W](#)] [[X](#)] [[Y](#)] [[Z](#)]

[s \(-s\) operator](#)

[S command \(vi\)](#)

[s conversion specification character](#)

s option

[fc command](#)

[paste command](#) [2nd](#)

[sh command](#)

s options

[tr command](#) [2nd](#)

[Sams Teach Yourself FreeBSD in 24 Hours](#)

[Sams Teach Yourself Red Hat Linux 8.0 in 24 Hours](#)

[Sams Teach Yourself Shell Programming in 24 Hours](#)

[Sams Teach Yourself Unix in 24 Hours](#)

saving

[matched characters](#) [2nd](#) [3rd](#) [4th](#)

[search order](#) [2nd](#)

searching

[.](#) [See also [pattern matching](#)]

files

[grep command](#) [2nd](#) [3rd](#) [4th](#) [5th](#) [6th](#) [7th](#) [8th](#) [9th](#) [10th](#)

[phone book entries](#) [2nd](#) [3rd](#) [4th](#) [5th](#)

[search order](#) [2nd](#)

[secondary prompts](#)

[Sed & Awk](#)

[sed command](#) [2nd](#)

[examples](#)

[syntax](#)

selecting

[shells](#) [2nd](#)

[semicolon \(;\)](#)

[\(semicolon\) command \(vi\)](#)

sending

[commands to background](#) [2nd](#) [3rd](#)

[set command](#) [2nd](#) [3rd](#) [4th](#) [5th](#) [6th](#) [7th](#) [8th](#)

[-- option](#) [2nd](#) [3rd](#) [4th](#)

[-x option](#) [2nd](#)

[executing without arguments](#) [2nd](#)

[reassigning positional parameters with](#) [2nd](#) [3rd](#)

sh command

[-x option](#) [2nd](#) [3rd](#) [4th](#)

[shell](#) [2nd](#) [3rd](#) [4th](#)

[command execution](#) [2nd](#) [3rd](#) [4th](#)

[defined](#)

[entering commands in](#) [2nd](#) [3rd](#)

[environmental control](#)

[filename substitution](#) [2nd](#)

[input redirection](#) [2nd](#) [3rd](#)

[login shell](#) [2nd](#) [3rd](#) [4th](#)

[getty program](#) [2nd](#)  
[init program](#) [2nd](#)  
[output redirection](#) [2nd](#) [3rd](#)  
[pipeline hookup](#) [2nd](#)  
[shell programming language](#) [2nd](#)  
    [comments](#) [2nd](#) [3rd](#) [4th](#)  
    [variables](#) [2nd](#) [3rd](#) [4th](#) [5th](#) [6th](#) [7th](#) [8th](#) [9th](#) [10th](#) [11th](#) [12th](#) [13th](#) [14th](#) [15th](#) [16th](#) [17th](#) [18th](#) [19th](#) [20th](#) [21st](#)  
    [variables.](#) [See [variables](#)]  
[starting up](#)  
trace mode  
    [disabling](#)  
    [enabling](#) [2nd](#)  
variables  
    [assigning values to](#)  
shell archive files  
    [creating](#) [2nd](#) [3rd](#) [4th](#) [5th](#)  
[shell programming language](#) [2nd](#)  
    [comments](#) [2nd](#) [3rd](#) [4th](#)  
    [# \(pound sign\)](#)  
shell programming languages  
    [variables](#)  
        [\\$# variable](#) [2nd](#) [3rd](#)  
        [\\$\\* variable](#) [2nd](#)  
        [\\${n} variable](#) [2nd](#)  
        [\\${variable} construct \(\\*\\*italicize variable\)](#) [2nd](#)  
        [arithmetic expansion](#) [2nd](#) [3rd](#)  
        [assigning to other variables](#)  
        [assigning values to](#) [2nd](#)  
        [displaying values of](#)  
        [examples](#) [2nd](#)  
        [filename substitution](#) [2nd](#) [3rd](#)  
        [naming conventions](#)  
        [null values](#) [2nd](#) [3rd](#)  
        [positional parameters](#) [2nd](#) [3rd](#) [4th](#) [5th](#)  
        [variable substitution](#) [2nd](#)  
[shell variables.](#) [See [variables](#)]  
shells  
    [Bash](#)  
    [compatibility summary](#) [2nd](#)  
jobs  
    [job\\_ids](#) [2nd](#)  
    [messages](#)  
    [stopping](#) [2nd](#)  
[Korn](#)  
    [restricted shell \(rsh\)](#) [2nd](#) [3rd](#) [4th](#)  
    [selecting](#) [2nd](#)  
    [shell modes](#) [2nd](#)  
    [subshells](#) [2nd](#) [3rd](#) [4th](#) [5th](#)  
[shift command](#) [2nd](#) [3rd](#) [4th](#) [5th](#)  
signals  
    [ignoring](#) [2nd](#)  
    [sending to programs](#)

[signal numbers](#) [2nd](#) [3rd](#)  
[trapping](#) [2nd](#) [3rd](#) [4th](#) [5th](#) [6th](#) [7th](#) [8th](#)  
single characters  
[matching](#) [2nd](#) [3rd](#)  
[single quote \('\)](#) [2nd](#) [3rd](#) [4th](#) [5th](#) [6th](#) [7th](#)  
sizing  
[command history](#)  
[command history file](#) [2nd](#)  
[skipping commands in loops](#) [2nd](#) [3rd](#) [4th](#)  
[skipping fields](#) [2nd](#)  
[slash \(/\)](#) [2nd](#) [3rd](#)  
[sort command](#) [2nd](#)  
[+ln option](#) [2nd](#)  
[-n option](#) [2nd](#)  
[-o option](#) [2nd](#)  
[-r option](#) [2nd](#)  
[-t option](#) [2nd](#) [3rd](#)  
[-u option](#) [2nd](#)  
[sorting files](#) [2nd](#)  
[arithmetic sorts](#) [2nd](#)  
[delimiter characters](#) [2nd](#) [3rd](#)  
[duplicate lines](#) [2nd](#)  
[reversing sort order](#) [2nd](#)  
[skipped fields](#) [2nd](#)  
[writing sorted data to standard output](#) [2nd](#)  
[source files](#)  
[special files](#)  
[special variables](#). [See [variables](#)]  
[standard error](#) [2nd](#) [3rd](#)  
[redirecting](#)  
[writing to](#) [2nd](#)  
[standard input](#) [2nd](#) [3rd](#) [4th](#)  
[closing](#)  
[translating characters from](#) [2nd](#) [3rd](#) [4th](#) [5th](#) [6th](#) [7th](#) [8th](#) [9th](#) [10th](#) [11th](#) [12th](#)  
[standard output](#) [2nd](#) [3rd](#) [4th](#)  
[closing](#)  
[writing sorted data to](#) [2nd](#)  
starting  
[shell](#)  
[startup](#)  
status  
[exit status](#) [2nd](#) [3rd](#)  
 [\\$? variable](#) [2nd](#) [3rd](#) [4th](#) [5th](#) [6th](#)  
[nonzero values](#)  
[read command](#) [2nd](#) [3rd](#) [4th](#) [5th](#)  
[zero](#)  
[of jobs](#)  
[status of processes, returning](#) [2nd](#)  
stopping  
[function execution](#)  
[jobs](#) [2nd](#) [3rd](#) [4th](#) [5th](#) [6th](#)  
[loops](#) [2nd](#)

[stream editor \(sed\)](#)

[-d option](#) [2nd](#)

[-n option](#) [2nd](#)

[examples](#) [2nd](#) [3rd](#) [4th](#) [5th](#)

[syntax](#)

streams

[stream editor \(sed\)](#)

[-d option](#) [2nd](#)

[-n option](#) [2nd](#)

[examples](#) [2nd](#) [3rd](#) [4th](#) [5th](#)

[syntax](#)

[string operators](#) [2nd](#) [3rd](#) [4th](#) [5th](#) [6th](#) [7th](#) [8th](#)

strings

[string operators](#) [2nd](#) [3rd](#) [4th](#) [5th](#) [6th](#) [7th](#) [8th](#)

[subscripts](#)

[subshells](#) [2nd](#) [3rd](#) [4th](#) [5th](#)

[passing variables to](#) [2nd](#) [3rd](#) [4th](#)

substitution

[parameter substitution](#) [2nd](#)

substituting

[variables](#) [2nd](#)

[substituting filenames](#) [2nd](#) [3rd](#) [4th](#)

[\\* \(asterisk\)](#) [2nd](#) [3rd](#) [4th](#)

[? \(question mark\)](#) [2nd](#)

[\[\] \(brackets\)](#) [2nd](#)

[examples](#) [2nd](#)

[multiple character matching](#) [2nd](#) [3rd](#) [4th](#)

[single character matching](#) [2nd](#) [3rd](#)

[variables](#) [2nd](#) [3rd](#)

substitution

[parameter substitution](#) [2nd](#)

[\\${#parameter} construct](#)

[\\${#variable} construct](#) [2nd](#)

[\\${parameter##pattern} construct](#)

[\\${parameter#pattern} construct](#)

[\\${parameter%pattern} construct](#)

[\\${parameter+value} construct](#)

[\\${parameter-value} construct](#)

[\\${parameter=value} construct](#)

[\\${parameter?value} construct](#)

[\\${parameter\[colon\]+value} construct](#) [2nd](#) [3rd](#)

[\\${parameter\[colon\]-value} construct](#) [2nd](#) [3rd](#)

[\\${parameter\[colon\]=value} construct](#) [2nd](#) [3rd](#)

[\\${parameter\[colon\]?value} construct](#) [2nd](#) [3rd](#)

[\\${parameter} construct](#) [2nd](#) [3rd](#)

[pattern matching constructs](#) [2nd](#) [3rd](#) [4th](#)

[tilde substitution](#) [2nd](#) [3rd](#) [4th](#) [5th](#)

[substitution \(command\)](#)

[\\$\(...\) construct](#) [2nd](#) [3rd](#) [4th](#) [5th](#) [6th](#) [7th](#) [8th](#) [9th](#)

[` \(backquote\)](#) [2nd](#) [3rd](#) [4th](#)

[expr command](#) [2nd](#) [3rd](#) [4th](#) [5th](#)

[summary of commands](#) [2nd](#)

suspending

[jobs](#) [2nd](#) [3rd](#) [4th](#)  
[symbolic links](#) [2nd](#)

**Team LiB**

◀ PREVIOUS

[\[SYMBOL\]](#) [\[A\]](#) [\[B\]](#) [\[C\]](#) [\[D\]](#) [\[E\]](#) [\[F\]](#) [\[G\]](#) [\[H\]](#) [\[I\]](#) [\[J\]](#) [\[K\]](#) [\[L\]](#) [\[M\]](#) [\[N\]](#) [\[O\]](#) [\[P\]](#) [\[Q\]](#) [\[R\]](#) [\[S\]](#) [\[T\]](#) [\[U\]](#) [\[V\]](#) [\[W\]](#) [\[X\]](#) [\[Y\]](#) [\[Z\]](#)

[t \(" " \t " "\) escape character](#)

[t \(" " \t " "\) escape characters](#)

t option

[sort command](#) [2nd](#) [3rd](#)

tapping

[signals](#) [2nd](#)

[temporary files](#) [2nd](#) [3rd](#)

[TERM signal](#)

[TERM variable](#) [2nd](#)

[terminal type](#) [2nd](#)

terminating

[function execution](#) [2nd](#)

[jobs](#) [2nd](#)

[loops](#) [2nd](#)

[test command](#) [2nd](#) [3rd](#) [4th](#)

[alternative format](#) [2nd](#)

[file operators](#) [2nd](#) [3rd](#)

[integer operators](#) [2nd](#) [3rd](#)

[logical AND operator \(-a\)](#) [2nd](#)

[logical negation operator \(!\)](#) [2nd](#)

[logical OR operator \(-o\)](#) [2nd](#)

[parentheses](#) [2nd](#)

[string operators](#) [2nd](#) [3rd](#) [4th](#) [5th](#) [6th](#) [7th](#) [8th](#)

[syntax](#) [2nd](#)

testing

[conditions in if commands](#)

[file operators](#) [2nd](#) [3rd](#)

[integer operators](#) [2nd](#) [3rd](#)

[logical AND operator \(-a\)](#) [2nd](#)

[logical negation operator \(!\)](#) [2nd](#)

[logical OR operator \(-o\)](#) [2nd](#)

[parentheses](#) [2nd](#)

[string operators](#) [2nd](#) [3rd](#) [4th](#) [5th](#) [6th](#) [7th](#) [8th](#)

[test command syntax](#) [2nd](#) [3rd](#)

text

[\\_](#) [See also [lines](#)]

characters

[extracting](#) [2nd](#) [3rd](#) [4th](#) [5th](#) [6th](#) [7th](#) [8th](#) [9th](#)

[translating from standard input](#) [2nd](#) [3rd](#) [4th](#) [5th](#) [6th](#) [7th](#) [8th](#) [9th](#)

editing

[sed command](#) [2nd](#) [3rd](#) [4th](#) [5th](#) [6th](#) [7th](#) [8th](#) [9th](#) [10th](#) [11th](#)

lines

[deleting](#) [2nd](#)

[duplicating](#) [2nd](#) [3rd](#) [4th](#) [5th](#) [6th](#)

[line numbering program](#) [2nd](#)

[pasting together](#) [2nd](#) [3rd](#) [4th](#) [5th](#)

[sorting](#) [2nd](#) [3rd](#) [4th](#) [5th](#) [6th](#) [7th](#) [8th](#) [9th](#) [10th](#)

pattern matching

[any character](#) [2nd](#) [3rd](#)  
[beginning of line](#) [2nd](#)  
[end of line](#) [2nd](#) [3rd](#)  
[grep command](#) [2nd](#) [3rd](#) [4th](#) [5th](#) [6th](#) [7th](#) [8th](#) [9th](#)  
[parameter substitution constructs](#) [2nd](#) [3rd](#) [4th](#)  
[precise number of characters](#) [2nd](#) [3rd](#) [4th](#)  
[saving matched characters](#) [2nd](#) [3rd](#) [4th](#)  
[specific characters](#) [2nd](#) [3rd](#)  
[summary of regular expressions](#) [2nd](#)  
[zero or more characters](#) [2nd](#) [3rd](#) [4th](#)

searching

[grep command](#) [2nd](#) [3rd](#) [4th](#) [5th](#) [6th](#) [7th](#) [8th](#) [9th](#) [10th](#)

tilde (~)

[tilde substitution](#) [2nd](#) [3rd](#) [4th](#)

[tilde substitution](#) [2nd](#) [3rd](#) [4th](#)

tile (~)

[tilde substitution](#)

time

[recording amount used](#)

time zones

[TZ variable](#) [2nd](#)

time/date

displaying

[date command](#) [2nd](#)

[times command](#) [2nd](#)

[tools\\_](#) [See [commands](#)] [2nd](#) [See [commands](#)]

tr command

[-d option](#) [2nd](#)

[-s option](#) [2nd](#)

[examples](#) [2nd](#) [3rd](#) [4th](#) [5th](#) [6th](#) [7th](#)

[syntax](#)

trace mode

[disabling](#)

[enabling](#) [2nd](#)

translating

[characters from standard input](#) [2nd](#) [3rd](#) [4th](#) [5th](#) [6th](#) [7th](#) [8th](#) [9th](#) [10th](#) [11th](#) [12th](#)

[trap command](#) [2nd](#) [3rd](#) [4th](#) [5th](#) [6th](#) [7th](#) [8th](#)

[executing without arguments](#) [2nd](#)

[ignoring signals](#) [2nd](#)

[resetting traps](#) [2nd](#)

[signal numbers](#)

[syntax](#)

traps

[creating](#) [2nd](#) [3rd](#)

[displaying](#) [2nd](#)

[resetting](#) [2nd](#)

[signal numbers](#) [2nd](#)

[true command](#)

[tutorials](#)

[twhile program](#) [2nd](#)

[type command](#) [2nd](#) [3rd](#) [4th](#)

types



[integer 2nd](#)  
[types \(data\)](#)  
[TZ variable 2nd](#)

**Team LiB**

◀ PREVIOUS

[\[SYMBOL\]](#) [\[A\]](#) [\[B\]](#) [\[C\]](#) [\[D\]](#) [\[E\]](#) [\[F\]](#) [\[G\]](#) [\[H\]](#) [\[I\]](#) [\[J\]](#) [\[K\]](#) [\[L\]](#) [\[M\]](#) [\[N\]](#) [\[O\]](#) [\[P\]](#) [\[Q\]](#) [\[R\]](#) [\[S\]](#) [\[T\]](#) [\[U\]](#) [\[V\]](#) [\[W\]](#) [\[X\]](#) [\[Y\]](#) [\[Z\]](#)

[u command \(vi\)](#)

[U command \(vi\)](#)

[u conversion specification character](#)

[u option](#)

[sort command](#) [2nd](#)

[u option \(set command\)](#)

[umask command](#) [2nd](#)

[unalias command](#) [2nd](#)

[underscore \(\\_\)](#) [2nd](#)

[uniq command](#)

[-c option](#)

[-d option](#) [2nd](#) [3rd](#)

[examples](#) [2nd](#) [3rd](#)

[syntax](#)

[Unix C Shell Field Guide, The](#)

[Unix in a Nutshell\[colon\] System V Edition](#)

[Unix Programmer's Manual, Volume II](#)

[Unix Programming Environment, The](#) [2nd](#)

[Unix Unleashed](#)

[unset command](#) [2nd](#) [3rd](#) [4th](#)

[until command](#) [2nd](#) [3rd](#) [4th](#) [5th](#) [6th](#) [7th](#) [8th](#) [9th](#) [10th](#) [11th](#)

[examples](#) [2nd](#) [3rd](#) [4th](#) [5th](#) [6th](#) [7th](#) [8th](#)

[syntax](#) [2nd](#)

[User's Reference Manual/System Administrator's Reference Manual](#)

[users](#)

[logged-in users](#)

[displaying](#) [2nd](#)

[utilities](#)

[\\_](#) [See also [commands](#), [shell](#)]

[defined](#)

[utilities.](#) [See [commands](#)]

[\[SYMBOL\]](#) [\[A\]](#) [\[B\]](#) [\[C\]](#) [\[D\]](#) [\[E\]](#) [\[F\]](#) [\[G\]](#) [\[H\]](#) [\[I\]](#) [\[J\]](#) [\[K\]](#) [\[L\]](#) [\[M\]](#) [\[N\]](#) [\[O\]](#) [\[P\]](#) [\[Q\]](#) [\[R\]](#) [\[S\]](#) [\[T\]](#) [\[U\]](#) [\[V\]](#) [\[W\]](#) [\[X\]](#) [\[Y\]](#) [\[Z\]](#)

[v \(\) escape character](#)

[v option](#)

[grep command](#) [2nd](#)

[v option \(set command\)](#)

[values](#)

[assigning to keyword parameters](#) [2nd](#)

[assigning to variables](#) [2nd](#) [3rd](#)

[comparing with case command](#)

[command syntax](#) [2nd](#) [3rd](#)

[pattern matching characters](#) [2nd](#) [3rd](#) [4th](#)

[pipe symbol \(|\)](#) [2nd](#) [3rd](#)

[displaying](#)

[null values](#) [2nd](#) [3rd](#)

[reassigning to positional parameters](#) [2nd](#) [3rd](#)

[variables](#) [2nd](#) [3rd](#) [4th](#) [5th](#)

[\\$!](#)

[\\$! variable](#) [2nd](#)

[\\$#](#)

[\\$# variable](#) [2nd](#) [3rd](#)

[\\$\\$](#)

[\\$\\$ variable](#)

[\\$\\*](#)

[\\$\\* variable](#) [2nd](#) [3rd](#)

[\\$-](#)

[\\$?](#)

[\\$? variable](#) [2nd](#) [3rd](#) [4th](#) [5th](#) [6th](#)

[\\$@](#)

[@\\$ variable](#) [2nd](#) [3rd](#)

[\\${n} variable](#) [2nd](#)

[\\${variable} construct \(\\*\\*italicize variable\)](#) [2nd](#)

[\\$0](#)

[\\$0 variable](#) [2nd](#)

[arithmetic expansion](#) [2nd](#) [3rd](#)

[assigning to other variables](#)

[assigning values to](#) [2nd](#)

[assigning variables to](#)

[CDPATH](#) [2nd](#) [3rd](#) [4th](#)

[displaying values of](#)

[ENV](#) [2nd](#)

[examples](#) [2nd](#)

[exporting](#) [2nd](#) [3rd](#) [4th](#) [5th](#) [6th](#) [7th](#) [8th](#) [9th](#) [10th](#)

[FCEDIT](#) [2nd](#)

[filename substitution](#) [2nd](#) [3rd](#)

[FPATH](#)

[HISTFILE](#) [2nd](#)

[HISTSIZE](#) [2nd](#)

[HOME](#) [2nd](#) [3rd](#)

[IFS](#)

[IFS variable](#) [2nd](#) [3rd](#) [4th](#) [5th](#)  
[LINENO](#)  
[listing](#) [2nd](#)  
[local variables](#) [2nd](#)  
[MAIL](#)  
[MAILCHECK](#)  
[MAILPATH](#)  
[naming conventions](#)  
[null values](#) [2nd](#) [3rd](#)  
[passing to subshells](#) [2nd](#) [3rd](#) [4th](#)  
[PATH](#) [2nd](#) [3rd](#) [4th](#) [5th](#) [6th](#) [7th](#) [8th](#) [9th](#) [10th](#) [11th](#) [12th](#)  
[PHONEBOOK](#) [2nd](#) [3rd](#) [4th](#) [5th](#)  
pointers  
  [creating](#)  
positional parameters  
  [defined](#) [2nd](#)  
  [left shifting](#) [2nd](#) [3rd](#)  
[PPID](#)  
[PS1](#) [2nd](#) [3rd](#)  
[PS2](#) [2nd](#) [3rd](#)  
[PS4](#)  
[PWD](#)  
[read-only variables](#) [2nd](#)  
  [creating](#) [2nd](#)  
[removing from environment](#) [2nd](#)  
[TERM](#) [2nd](#)  
[TZ](#) [2nd](#)  
[unsetting](#) [2nd](#) [3rd](#)  
[variable substitution](#) [2nd](#)  
[vartest program](#) [2nd](#)  
[vartest2 program](#) [2nd](#)  
[vartest3 program](#) [2nd](#)  
[vartest4 program](#) [2nd](#)  
[vartest5 program](#)  
[verbose shell mode](#)  
[vi line edit mode](#) [2nd](#) [3rd](#) [4th](#) [5th](#) [6th](#) [7th](#) [8th](#) [9th](#) [10th](#) [11th](#)  
  [command mode](#)  
  [commands](#) [2nd](#) [3rd](#) [4th](#) [5th](#) [6th](#)  
    [\\$](#) [2nd](#)  
    [/](#) [2nd](#) [3rd](#)  
    [O](#) [2nd](#)  
    [a](#) [2nd](#)  
    [b](#) [2nd](#)  
    [dw](#)  
    [h](#) [2nd](#) [3rd](#)  
    [i](#) [2nd](#)  
    [j](#) [2nd](#) [3rd](#)  
    [k](#) [2nd](#) [3rd](#)  
    [l](#) [2nd](#) [3rd](#)  
    [r](#)  
    [w](#) [2nd](#)  
    [x](#) [2nd](#) [3rd](#)

[input mode](#)  
[vi shell mode](#)

**Team LiB**

◀ PREVIOUS

[\[SYMBOL\]](#) [\[A\]](#) [\[B\]](#) [\[C\]](#) [\[D\]](#) [\[E\]](#) [\[F\]](#) [\[G\]](#) [\[H\]](#) [\[I\]](#) [\[J\]](#) [\[K\]](#) [\[L\]](#) [\[M\]](#) [\[N\]](#) [\[O\]](#) [\[P\]](#) [\[Q\]](#) [\[R\]](#) [\[S\]](#) [\[T\]](#) [\[U\]](#) [\[V\]](#) [\[W\]](#) [\[X\]](#) [\[Y\]](#) [\[Z\]](#)

[w \(-w\) operator](#)

[w command \(vi\)](#) [2nd](#)

w option

[wc command](#)

[wait command](#) [2nd](#)

[\\$! variable](#) [2nd](#)

[example](#)

[syntax](#) [2nd](#)

[waiting for processes](#) [2nd](#) [3rd](#) [4th](#) [5th](#)

[wc command](#) [2nd](#)

[Web sites](#) [2nd](#)

[Cygwin](#)

[Free Software Foundation](#)

[Korn shell](#) [2nd](#)

[O'Reilly and Associates Web site](#)

[POSIX standard](#)

[while command](#) [2nd](#) [3rd](#) [4th](#) [5th](#)

[whitespace characters](#)

[who command](#) [2nd](#)

words

counting

[wc command](#) [2nd](#)

working directory

[printing](#) [2nd](#)

writing

[sorted data to standard output](#) [2nd](#)

[to standard error](#) [2nd](#)

[\[SYMBOL\]](#) [\[A\]](#) [\[B\]](#) [\[C\]](#) [\[D\]](#) [\[E\]](#) [\[F\]](#) [\[G\]](#) [\[H\]](#) [\[I\]](#) [\[J\]](#) [\[K\]](#) [\[L\]](#) [\[M\]](#) [\[N\]](#) [\[O\]](#) [\[P\]](#) [\[Q\]](#) [\[R\]](#) [\[S\]](#) [\[T\]](#) [\[U\]](#) [\[V\]](#) [\[W\]](#) [\[X\]](#) [\[Y\]](#) [\[Z\]](#)

[x \(-x\) operator](#)

[x command \(vi\)](#) [2nd](#) [3rd](#)

[x conversion specification character](#)

[X conversion specification character](#)

[x option](#)

[set command](#) [2nd](#)

[sh command](#) [2nd](#) [3rd](#) [4th](#)

[x option \(set command\)](#)

[xtrace shell mode](#)

**Team LiB**

← PREVIOUS

[\[SYMBOL\]](#) [\[A\]](#) [\[B\]](#) [\[C\]](#) [\[D\]](#) [\[E\]](#) [\[F\]](#) [\[G\]](#) [\[H\]](#) [\[I\]](#) [\[J\]](#) [\[K\]](#) [\[L\]](#) [\[M\]](#) [\[N\]](#) [\[O\]](#) [\[P\]](#) [\[Q\]](#) [\[R\]](#) [\[S\]](#) [\[T\]](#) [\[U\]](#) [\[V\]](#) [\[W\]](#) [\[X\]](#) [\[Y\]](#) [\[Z\]](#)

[Y command \(vj\)](#)

**Team LiB**

← PREVIOUS



**Team LiB**

← PREVIOUS

[\[SYMBOL\]](#) [\[A\]](#) [\[B\]](#) [\[C\]](#) [\[D\]](#) [\[E\]](#) [\[F\]](#) [\[G\]](#) [\[H\]](#) [\[I\]](#) [\[J\]](#) [\[K\]](#) [\[L\]](#) [\[M\]](#) [\[N\]](#) [\[O\]](#) [\[P\]](#) [\[Q\]](#) [\[R\]](#) [\[S\]](#) [\[T\]](#) [\[U\]](#) [\[V\]](#) [\[W\]](#) [\[X\]](#) [\[Y\]](#) [\[Z\]](#)

[zero \(0\) exit status](#)

[zero exit status](#)

**Team LiB**

← PREVIOUS